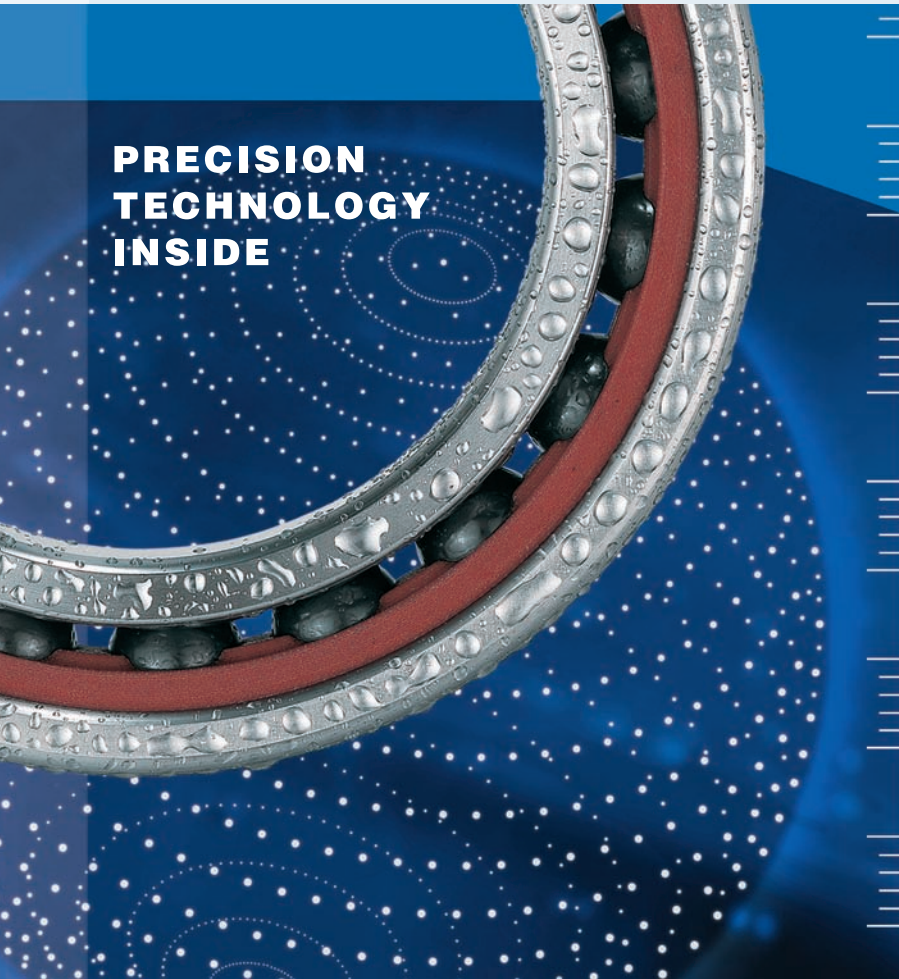




**PRECISION  
TECHNOLOGY  
INSIDE**



**BARDEN SUPER PRECISION BALL BEARINGS –  
SPECIALITY PRODUCTS**

**SCHAEFFLER GROUP**

# INTRODUCTION

## How This Catalogue Is Organised

Welcome to the world of Barden Precision Bearings.

This catalogue contains details of “Speciality Products” which are super precision bearings and assemblies for all applications except Machine Tool (see page 145 for details).

If you have a copy of an earlier Barden catalogue, you’ll notice this version is organised differently. First of all, the catalogue is divided into two primary sections:

1) Product, 2) Engineering.

The product section is organised by bearing type:

- Deep Groove Instrument (Inch)
- Deep Groove Instrument (Metric)
- Deep Groove Flanged (Inch)
- Deep Groove Thin Section (Inch)
- Deep Groove Spindle and Turbine (Metric)
- Angular Contact (Inch)
- Angular Contact (Metric)
- Special Bearings

Each series of bearings is listed by bore diameter — from the smallest to the largest.

Another key change to this catalogue is that data on limiting speeds, static capacity and basic dynamic load ratings has been moved to the appropriate product page, alongside bearing dimensions and nomenclature.

Additional relevant data (e.g. on seal and cage options, etc.) can also now be found in the appropriate product sections, instead of appearing in the general engineering reference section, as before.

The engineering section also has been reorganised. Much of the specific bearing operating data, as mentioned, can now be found in the appropriate product section. New material has also been added to the engineering section, particularly on handling and mounting procedures.

Also note that this catalogue has two fold-out pages at the beginning of the Deep Groove and Angular Contact product sections. Each fold-out page contains detailed descriptions of appropriate bearing nomenclature.

These changes improve the usefulness of our primary product catalogue. Finding the right Barden Precision Bearing is now easier than ever.

Finally, we would welcome any comments or suggestions you may have regarding our new format. And, as always, thank you for choosing Barden.



*Barden Super Precision Bearing plant located in Plymouth, Devon, U.K.*



*Barden Super Precision Bearing plant in Danbury, Connecticut, U.S.A.*



*Winsted Precision Ball plant in Winsted, Connecticut, U.S.A.*

# TABLE OF CONTENTS

## Capabilities

Barden's Commitment to Excellence	4
International Recognition	4
Barden Products	4
Precision Classes	5
Going Beyond ABEC Standards	5
Sizes and Configurations	6
Applications	7
Quality Control	8
Product Engineering	9

## Product Section, Product Tables

Deep Groove	11
Deep Groove Nomenclature (fold out page)	13
Deep Groove Instrument (Inch) Tables	16
Deep Groove Instrument (Metric) Tables	20
Deep Groove Flanged (Inch) Tables	22
Deep Groove Thin Section (Inch) Tables	24
Deep Groove Spindle & Turbine (Metric) Tables	28
Angular Contact	35
Angular Contact Nomenclature (fold out page)	37
Angular Contact (Inch) Tables	40
Angular Contact (Metric) Tables	42
Special Applications	49
High Speed Dental Handpiece Bearings	52
Vacuum Pump Bearings	54
Magnetic Spindle "Touchdown" Bearings	54
Auto Sport/Formula 1 Racing Bearings	56
Gyro Bearings	58
Aerospace Bearings	60
X-Ray Bearings	62
Canning Industry Bearings	64

## Engineering Section

<b>Bearing Selection</b>	69–113
Selecting the Right Bearing	69
Operating Conditions	69
Bearing Types	69
Bearing Size	70
Diameter Series	71
Sizes and Applications	71
Ball and Ring Materials	71
Ceramic Hybrids	72
X-life Ultra Bearings	74
Surface Engineering	75
Solid Lubrication	76
Bearing Cages	77
Bearing Closures	82

Attainable Speeds	84
Limiting Speed Factors	84
Speedability Factor dN	84
Internal Design Parameters	85
Ball Complement	85
Raceway Curvature	85
Radial Internal Clearance	85
Contact Angle	88
Axial Play	90
Ball Complement Tables	92
Preloading	95
Bearing Yield	95
Preloading Techniques	95
Lubrication	100
Tolerances and Geometric Accuracy	108

## Bearing Performance

Bearing Life	114
Service Life	114
Bearing Capacity	114
Fatigue Life	116
Sample Fatigue Life Calculation	118
Miscellaneous Life Considerations	119
Grease Life	120
Vibration	121
Yield Stiffness	122
Torque	122
Measurement and Testing Techniques	122

## Bearing Application

Mounting and Fitting	124
Shaft and Housing Fits	125
Fitting Practice	125
Fitting Notes	126
Shaft and Housing Size Determination	127
Maximum Fillet Radii	128
Shaft and Housing Shoulder Diameters	129
Abutment Tables	130
Random and Selective Fitting	139
Calibration	139
Random vs. Specific Calibration	139
Maintaining Bearing Cleanliness	141
Handling Guidelines	143

Barden Warranty	144
Conversion Table	144
Literature and Website Information	145
Index	146

The data, specifications and characteristics in this catalogue were developed using sound testing and engineering techniques and are believed to be accurate. Every attempt has been made to preclude errors. However, use of this information is the customer's responsibility. The Barden Corporation's sole responsibility or liability is contained in the Warranty statement at the end of this catalogue.

## CAPABILITIES

Quality and reliability...every time.



### **Barden's Commitment to Excellence**

The Barden Corporation was originally founded to make ball bearings of exceptional quality requiring rotational precision and tolerance control beyond the scope of technology then available. Today, over fifty years later, Barden continues to meet the challenge of manufacturing to super-precise/super-critical levels, and is recognised as an industry leader in this achievement. Excellence in manufacturing remains our guiding principle.

Barden produces thousands of bearing types, sizes and designs for a wide range of precision applications serving narrow – but highly demanding – market segments, like spindle and turbine bearings for industrial machinery and aircraft accessories, as well as instrument bearings for medical applications and gyroscopes.

Barden's goal remains not only to provide the highest quality, most precise bearings that can be made, but to enable our customers to compete more successfully in the markets they serve.

Regardless of design, all Barden bearings share one thing in common: they adhere to the highest standards possible, with tolerances measured in nanometers.

### **International Recognition**

The Barden name – long synonymous with quality, precision and excellence – is known and respected in virtually every industrialised nation, including the Far East.

In 1991, Barden became part of FAG Kugelfischer Georg Schaefer AG and now forms the nucleus of its Business Unit – Precision Bearings. Also included in this division are Barden U.K. and Winsted Precision Ball, together with facilities in Stratford, Canada and Schweinfurt, Germany.

Barden's customers are served primarily by a staff of Barden Sales Engineers. The replacement market is served by approximately 1,000 distributor outlets. Both are supplemented by a network of agents and distributors throughout the world.

With this global distribution system, Barden can provide bearings of identical quality at any point of need. Customers include multinational companies that buy Barden bearings in more than one country.

### **Barden Products**

The Barden product line encompasses predominantly radial, single row, super precision angular contact (separable and non-separable) and deep groove ball bearings. Ball bearings are made to exacting ABEC-7 and ABEC-9 specifications, standards which Barden routinely exceeds.

Barden super precision bearings come in inch or metric dimensions with diameters ranging from 4mm (5/32") O.D. up to 300mm (11<sup>1</sup>/<sub>2</sub>") O.D. A variety of seals, shields and metallic/nonmetallic cage designs are available to satisfy most requirements. Many Barden bearings operate comfortably at speeds ranging to 2.0 million dN (bore in mm × RPM), or above.

## CAPABILITIES

### Quality and reliability...every time.

#### Precision Classes

Precision ball bearings are manufactured to tolerance standards set by the Annular Bearing Engineers Committee (ABEC) of the American Bearing Manufacturers Association (ABMA). These standards have been accepted by the American National Standards Institute (ANSI) and conform essentially with equivalent standards of the International Organisation for Standardisation (ISO).

ABEC standards define tolerances for several major bearing dimensions and characteristics. They are divided into envelope dimensions (bore, O.D. and width) and bearing geometry. General-purpose, large deep groove and angular contact “spindle and turbine” ball bearings are manufactured to precision classes ABEC 1, ABEC 3, ABEC 5, ABEC 7 and ABEC 9 (ISO P0, P6, P5, P4 and P2). All Barden bearings of these types meet or exceed ABEC 7 geometric standards. Bores and O.D.’s may be calibrated for greater mounting flexibility. Barden deep groove spindle bearings meet or exceed ABEC 7.

Instrument bearings are produced in comparable classes, with added refinements designated by suffixes: ABEC 3P (ISO P6), ABEC 5P (ISO P5A), ABEC 7P (ISO P4A) and ABEC 9P (ISO P2). Barden bearings in this category are made to ABEC 7P (ISO P4A) or better.

Barden thin section “torque tube” bearings are manufactured to either ABEC 5T or ABEC 7T, according to requirements.

#### Going Beyond ABEC Standards

While ABEC classes are very helpful in categorising precision, they are not all-inclusive. At Barden, we are concerned about total bearing quality and “fitness for use” in critical applications. We often maintain closer tolerances than specified and we address many factors affecting bearing performance and life that are not covered by ABEC standards.

ABEC criteria, for example, do not include functional testing of assembled bearings, yet this measure can be extremely important. Barden applies self-established standards, using a number of proprietary tests and measuring equipment to ensure that we deliver



*Barden precision bearings are manufactured to ABEC 7 and ABEC 9 tolerances and are available in sizes ranging from 4mm (5/32") O.D. to 300mm (11 1/2") O.D.*

quiet, smooth-running bearings that will perform exceptionally well.

Bearing design is also not included in ABEC standards, but it too can make the difference between success and failure in bearing use. Barden design criteria are based on knowledge of all the factors which are significant for individual applications.

Thus, a Barden bearing may have specific low torque characteristics for a gyro gimbal, extra stiffness for textile spindle, or extremely high reliability for an aerospace accessory application.

Because ball quality affects the ability of a bearing to run smoothly, Barden uses both steel and ceramic balls produced to its own exacting specifications for ball geometry, finish and size control. Winsted Precision Ball supplies Barden with both steel and ceramic balls.

## **CAPABILITIES**

### **Quality and reliability...every time.**

#### **Sizes**

Barden bearings are supplied in both inch and metric dimensions. They are categorised as either miniature and instrument or spindle/turbine. This distinction is primarily size-related but is sometimes application-related.

#### **Configurations**

Barden manufactures deep groove and angular contact (separable and non-separable) bearings, some of which are available with flanged outer rings.

Flanged bearings are especially useful in through-bored housings. The inboard side of the flange provides an accurate positioning surface for bearing alignment, eliminating a need for housing shoulders or shoulder rings.

Extra wide, or cartridge width, deep groove bearings are available in Series 9000 for applications requiring extended operation without relubrication. Series 9000 bearings have more interior free volume and therefore hold more grease.

All Barden bearings can be equipped with ceramic balls for increased speedability, or improved lubricant life in extreme applications or hostile environments. Considerable experience has now been established in most theatres of bearing application, and the considerable benefits are now well proven.

Most Barden bearings are available with a variety of cage and closure options.

# CAPABILITIES

## Applications

Many now-standard bearings featured in this catalogue were once considered “special,” since they offered users something new in precision, size or configuration. At any given time, Barden has dozens of such new designs and developments being used very successfully in limited quantities. Current examples of Barden bearing applications include:

- Turbo molecular pumps
- Jet engine starters
- Auxiliary aircraft equipment
- Gyroscopes for marine & aerospace applications
- X-Ray tubes
- Dental
- Formula 1
- Canning



*Barden precision miniature and instrument bearings are an integral part of dental drill design, where high speeds, reliable performance and low maintenance are critical.*



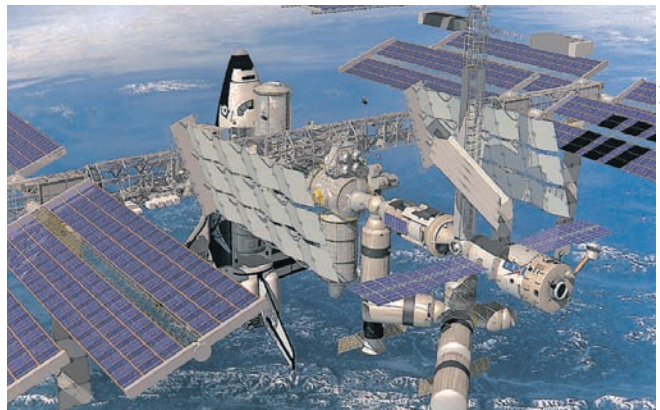
*The precision bearings found in CAT scanner X-ray tubes use a special Barden bearing design which must operate in a vacuum under boundary lubrication conditions.*



*Commercial aviation applications include a wide variety of aircraft accessories and critical components, and comprise a large percentage of Barden's core business.*



*Vacuum pumps place severe demands on precision bearings which must operate reliably under extreme conditions and meet long life requirements.*



*The Barden super precision bearings used in the International Space Station must meet stringent performance requirements with minimal lubrication.*

# CAPABILITIES

## Quality Control

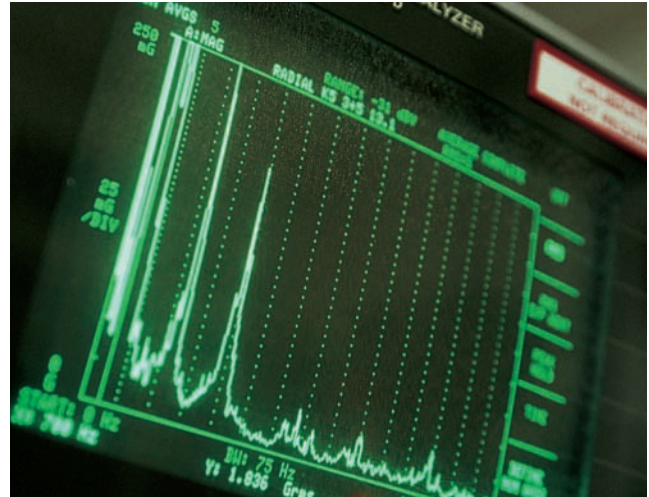
### Quality Control

Barden facilities are ISO 9001 certified. The quality control systems used at Barden U.S. comply fully with MIL-I-45208, Inspection System Requirements; MIL-H-6875, Heat Treat Procedures and ISO 10012-1, Quality Assurance Requirements for Measuring Equipment (formerly MIL-STD-45662). Barden U.S. is also certified by The National Aerospace and Defense Contractors Accreditation Program (NADCAP) for our non-destructive testing processes and is an approved supplier for the Federal Aviation Administration. Barden U.K. is similarly an approved supplier for the U.K. Civil Aviation Authority. These controls are coupled with a planned flexibility which enables Barden to comply with specific requirements of individual customers through a system of quality levels, inspections levels and certification of our product.

Quality is built into all Barden products. This thinking is applied to every aspect of manufacturing, from raw materials to packaged assembled bearings.

Through the use of Statistical Process Control, the Quality Engineering staff determines and monitors process capabilities to assure that process tolerances can be maintained. In-process machine control is facilitated using precontrol. These statistical methods are employed as production tools to gain better and more consistent quality.

The inspection department is the operating arm of our quality control process. Each lot of parts or assembled bearings must conform to quality requirements before being allowed to move to the next operation. Rather than delay inspection until operations have been completed, Barden's operators are certified through rigorous training and auditing to perform inspection operations during the manufacturing process. Our "Certified Supplier" programme ensures that our suppliers are top notch, consistently supplying us with acceptable product.



*Functional testing — like this vibration analysis — is a critical and on-going part of Barden's quality control program.*

The Metrology Department of Barden's quality control organisation provides basic standards of reference, using many advanced types of instrumentation. All linear measurements are certified to The National Institute of Standards and Technology.

Our Metallurgical and Chemical Laboratories are the surveillance unit for all incoming bearing steel, lubricants, cage material and other supplies. These laboratories work closely with other laboratories, universities and manufacturers to develop the highest quality parts, new bearing cleaning equipment, and the most advanced heat treating systems.



# **CAPABILITIES**

## **Product Engineering**

### **Product Engineering**

Barden Product Engineering services are available to all customers and prospective users of Barden precision bearings. Our engineers and technicians have capabilities in every area of bearing design, application, testing and development. When bearing performance involving torque, vibration or stiffness is an issue, they can perform computer analysis of characteristics and requirements in order to determine a suitable bearing design.

If standard catalogue bearings lack the necessary characteristics for a particular application, our Product Engineering Department can design a special bearing to satisfy your need.

With over 50 years of specialisation in the field of precision ball bearings, Barden engineers can draw upon a wealth of technical information to aid in failure analysis or troubleshooting of performance problems. They can readily identify the contributing causes and recommend solutions to improve bearing performance or useful life.

Our Product Development Laboratories conduct special investigations into new materials, coatings, lubricants and bearing designs. These laboratories are the center for Barden's work on unusual bearing problems, special environmental testing and vibration analysis. Endurance and reliability testing is also performed here.

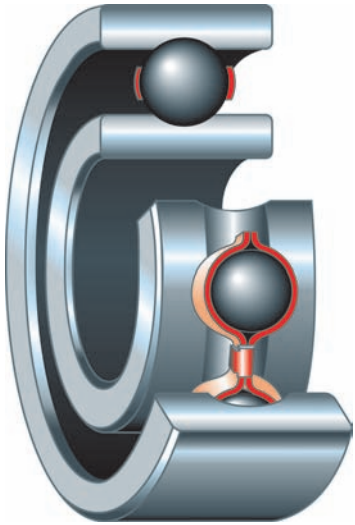
If you have a particular problem that you would like Barden's engineers to review, please contact your Barden Sales or Application Engineer, or an Authorised Barden Distributor.



# DEEP GROOVE BEARINGS



# DEEP GROOVE BEARINGS



## Deep Groove Bearing Design

Deep groove ball bearings have full shoulders on both sides of the raceways of the inner and outer rings. They can accept radial loads, thrust loads in either direction, or a combination of loads.

The full shoulders and the cages used in deep groove bearings make them suitable for the addition of closures. Besides single deep groove bearings with closures, Barden also offers duplex pairs with seals or shields on the outboard faces.

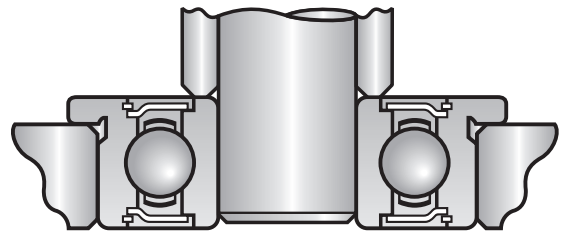
Deep groove bearings are available in many sizes, with a variety of cage types. Their versatility makes deep groove bearings the most widely used type.

Ceramic (silicon nitride) balls can be specified to increase bearing stiffness, reduce vibration levels and prolong bearing life.



## Flanged bearings

Flanged bearings provide solid mounting for good axial control and eliminate the need for housing shoulders or shoulder rings. Housings can be through-bored to reduce manufacturing costs and simplify assembly. When flanged bearings are used, the housing mounting surfaces must be accurately machined to properly position and support the bearings.



*Fig. 1. Flanged bearings are recommended when housing designs cannot accommodate full bearing width or where the quality of housing bore is a concern.*

# DEEP GROOVE BEARINGS

## Nomenclature

### Example:

**S R2 SS W X52 K3 VK DB ER C O-11**

Materials & Special Processes

Size & Series

Closures

Cage

Special Features

Lubrication

Calibration

Radial Runout

Duplexing & Preload

Functional Test

Radial Play

### Materials & Special Processes

- A – AISI 440C rings and balls (500 series)
  - BC – Barrier coating
  - P – TCP coating of rings and balls
  - C – Ceramic Balls
  - 30X – 'X Life Ultra' rings
  - S – AISI 440C rings and balls
  - M – M50 rings and balls
  - T – T5 rings and T15 balls
  - V – Denotes ABEC 5T for torque tube and extra thin series
- No symbol indicates SAE 52100 rings and balls

### Sizes and Series

- R – Inch series instrument
- R100 – Inch series miniature
- R1000 – Inch series extra thin
- 00M00 – Metric series instrument
- 500 – Inch series torque tube
- N500 – Inch series torque tube narrow width – both rings
- 30 – Metric series spindle/turbine
- 100 – Metric series spindle/turbine
- 200 – Metric series spindle/turbine
- 300 – Metric series spindle/turbine
- 1900 – Metric series spindle/turbine
- 9000 – Metric series S & T cartridge width
- FR – Inch series instrument flanged
- FR100 – Inch series miniature flanged
- (F)RW/(F)RW100 – wide inner ring
- Z – Special bearing
- SCB – Special customer bearing

### Closures

- S – Single shield
  - SS – Double shield
  - A – Single non-contact Barshield
  - AA – Double non-contact Barshield
  - F – Single Flexeal
  - FF – Double Flexeal
  - U – Single Synchro Seal
  - UU – Double Synchro Seal
  - Y – Single Barseal
  - YY – Double Barseal
  - VV – Double Viton Barseal
  - PP – Double Polyacrylic Barseal
  - RS – Single shield fitted into plain side of flanged bearing
- No symbol indicates open bearing

### Cages

- No symbol indicates the standard cage of either a crown snap or two piece ribbon.
- W – Stainless steel 2 piece ribbon loosely clinched
  - TA – Reinforced phenolic one piece snap
  - ZA – Teflon<sup>®</sup> hollow cylinders
  - TB – BarTemp<sup>®</sup> one piece snap self lubricating
  - T – Phenolic/aluminum 2 piece machined and riveted
  - TMT – Nylon one piece snap moulded
- For additional cage types consult 'Cage Options' in the Engineering Section.

### Special Features

- Letters 'X' or 'Y' followed by numbers indicate special features. Some of these are now 'standard' and appear in the bearing tables. Some commonly used are:
- X200 – Oil tight seal between shield and outer ring recess
  - X204 – Customer part number marked on bearing
  - X216 – Shield and snap wires shipped disassembled
- Consult Barden Engineering for details.

### Lubrication

- The pre-lubrication type is always indicated within the bearing number on the packaging.
- O or OJ numbers denote oil
  - G or GJ numbers denote grease
- Popular lubricants are listed within 'Lubrication' in the Engineering section.

### Calibration

- Bearings are available with bore and O/D calibrated into steps of 0.0001", 0.00005" or 0.001mm.
- C – Bore and O/D in 0.0001" (0.0025mm) steps
  - C44 – Bore & O/D in 0.00005" (0.00125mm) steps
  - O – is used when no calibration is required, ie: CXO - bore only calibrated in 0.0001" steps
  - Groups may be combined, ie
  - C4X – Bore is calibrated in 0.00005" steps and O/D in 0.0001" steps
  - CM – Special metric calibration in 0.001mm, inner ring bore only. See 'Calibration' in Engineering section.

### Radial Runout

- E – Special radial runout consult Barden
- R – Inner ring marked for high point of radial runout
- R1 – Outer ring marked for high point of radial runout
- R2 – Both inner and outer rings marked for high point of radial runout

### Duplexing & Preloading

- For duplex sets, letter symbol indicates type of mounting. If followed by a number, this is preload in pounds, otherwise standard pre-loads apply – see 'Preload' in Engineering Section.
- DB – Back to back mounting
  - DF – Face to face mounting
  - DT – Tandem mounting
  - D – Universal mounting (either DB, DF or DT)

### Functional Test

- Most small deep groove bearings and 30 Series are available with low torque characteristics. The standard levels are designated as follows:
- V – Low torque assured
  - VK – Very low starting torque assured
  - VM – Very low running torque assured
  - VT – Individual torque trace supplied to VM limits
- Consult Barden for specific torque levels.

### Radial Play

- K – Separating symbol
- Numeric code indicates range of radial play. For explanation of single digit numbers consult 'Radial Play' in the Engineering Section.
- Double digits e.g., 25, or four digits e.g., 1117, indicate actual radial play in 0.0001", i.e.
- K25 – 0.0002" – 0.0005" (0.005mm – 0.013mm)
  - 1117 – 0.0011" – 0.0017" (0.028mm – 0.043mm)

# DEEP GROOVE BEARINGS

## Product Series Descriptions: Series R, R100, R1000, FR, 500, M and 30

### Series R, R100, R1000, FR, 500, M and 30

**Series R and R100** deep groove bearings have full shoulders on both sides of the raceways of the inner and outer rings. They can accept radial loads, thrust loads in either direction, or combinations of loads. They are manufactured to inch dimensions.

**Series R1000** deep groove bearings have full shoulders on both sides of the raceways of the inner and outer rings. They can accept radial loads, thrust loads in either direction, or combinations of loads. This series consists of thin-section bearings with a consistent cross-sectional height of 3.175mm in all bore sizes to save weight and space. Large complement of small balls also contributes low torque characteristics.

**Series FR** deep groove bearings have full shoulders on both sides of the raceways of the inner and outer rings. The outer rings of Series FR bearings are flanged to provide accurate positioning surfaces. These bearings are easily installed in through-bored holes, eliminating the need for housing shoulders or shoulder rings. They are manufactured to inch dimensions. They can accept radial loads, thrust loads in either direction, or combinations of loads.

**Series 500** deep groove bearings are lightweight, thin-section bearings with full shoulders on both sides of the raceways of the inner and outer rings. They can accept radial loads, thrust loads in either direction, or a combination of loads.

**Series M and 30** deep groove bearings have full shoulders on both sides of the raceways of the inner and outer rings. They can accept radial loads, thrust loads in either direction, or combinations of loads. They are manufactured to metric dimensions.

**Bearing Data:** Bearing data applicable to these bearings is shown in the tables beginning on page 16. Lubrication and mounting data can be found in the Engineering section.

**Cages:** Series R, R100 and FR standard cage is a one-piece steel snap-in type (no symbol) up through R3. A two-piece ribbon cage is used for R4 and up. For other available cages, see following product tables or consult Barden. Series R1000 and 500 standard cage is a one-piece phenolic snap-in type (symbol TA). Some sizes are also available with Teflon® ball separators (symbol ZA). For other cage options, consult Barden. Series 30 standard cage is a two-piece steel ribbon type (no symbol). Some sizes are also available with a one-piece phenolic snap-in type (symbol TA) or a two-piece riveted phenolic, aluminum-reinforced type (symbol T); see table on page 78. For other cage options, consult Barden.

**Closures:** In bearing nomenclature, symbol SS denotes double shield; FF denotes double seal (Flexeal). To specify single shield or seal, omit one S or F in bearing number.

**Attainable Speeds:** Limits given are for lightly loaded single bearings. See Engineering section, page 84, for qualifications. For flanged bearings, limiting speeds are the same as the equivalent size of unflanged bearings.

**Materials:** Series R, R100, R1000 and FR standard material is AISI 440C stainless steel; some sizes are available in SAE 52100 bearing steel. Series 500 and M standard material is AISI 440C stainless steel; some sizes are available in SAE 52100 bearing steel. Series 30 standard material is SAE 52100 bearing steel. Most sizes are also available in AISI 440C stainless steel.

**Duplexing:** Most bearings are available in matched pairs for duplex DB or DF mounting. See details in the Engineering section.

**Lubricant:** Desired lubrication should be specified when ordering, based on torque, speed and temperature conditions of the application. See details in the Engineering section.

# DEEP GROOVE BEARINGS

## Product Series Descriptions: Series 100, 200, 300 and 9000

### Series 100, 200, 300 and 9000

*Metric Extra Light, Light and Medium Series*

**Series 100, 200 and 300** deep groove bearings have full shoulders on both sides of the raceways of the inner and outer rings and are available in matched pairs for duplex mounting.

**Series 9200 and 9300** deep groove bearings are cartridge width (extra wide) bearings with full shoulders on both sides of the raceways of the inner and outer rings. Extra width Series 9200 and 9300 bearings have more free volume in the bearing interior than Series 200 or 300, allowing a greater grease capacity for longer life. Series 9000 bearings are suitable for installations requiring lengthy operation without relubrication.

**Bearing Data:** Bearing data applicable to these bearings is shown in the following tables. Lubrication and mounting data can be found in the Engineering section.

**Cages:** Standard cage is a two-piece steel ribbon type (no symbol). Most sizes are also available with a two-piece riveted phenolic, aluminum-reinforced type (symbol T). Some sizes are available with a one-piece filled nylon snap-in type (symbol TMT). For other cage options, see Engineering section, page 78.

**Closures:** Most are available in shielded and sealed versions. In bearing numbers that follow, symbol SS denotes double shield; FF denotes double seal (Flexeal). To specify single shield or seal, omit one S or F in bearing number.

**Attainable Speeds:** Limits given are for lightly loaded single bearings.

**Material:** Standard material is SAE 52100 steel.

**Lubricant:** Desired lubrication should be specified when ordering, based on the torque, speed and temperature conditions of the application. See details in the Engineering section, page 100.

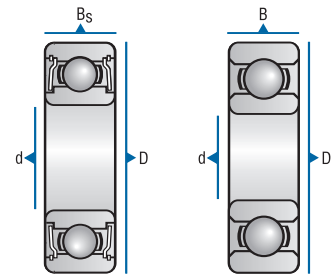
**Loads:** Can accept radial loads, thrust loads in either direction, or combinations of loads.

**Duplexing:** Deep groove bearings can be supplied in matched pairs for duplex DB, DF or DT mounting. Consult Barden Engineering for details.

# DEEP GROOVE INSTRUMENT (INCH)

**Bore Diameters: 1.191mm to 4.762mm**

- Open, shielded and sealed



BASIC BEARING NUMBER	Bore Diameter d		Outside Diameter D		Width				Maximum Shaft/Housing Radius Which Bearing Corner Will Clear		nd <sup>2</sup>	Static Capacity		Basic Dynamic Load Rating C (N)
	mm	inch	mm	inch	B	B <sub>s</sub>	r Max.	mm	inch	Radial C <sub>0</sub> (N)		Thrust T <sub>0</sub> (N)		
SR0	1.191	0.0469	3.967	0.1562	1.588	0.0625	2.380	0.0937	0.08	0.003	0.0059	13	36	85
SR1	1.397	0.0550	4.762	0.1875	1.984	0.0781	2.779	0.1094	0.08	0.003	0.0093	22	53	129
SR1-4	1.984	0.0781	6.350	0.2500	2.380	0.0937	3.571	0.1406	0.08	0.003	0.0124	31	89	169
SR133*	2.380	0.0937	4.762	0.1875	1.588	0.6250	2.380	0.9370	0.08	0.003	0.0078	18	58	111
SR143	2.380	0.0937	6.350	0.2500	2.380	0.0937	2.779	0.1094	0.08	0.003	0.0124	31	89	169
SR1-5	2.380	0.0937	7.938	0.3125	2.779	0.1094	3.571	0.1406	0.08	0.003	0.0234	44	89	254
SR144*	3.175	0.1250	6.350	0.2500	2.380	0.0937	2.779	0.1094	0.08	0.003	0.0124	31	89	169
SR144X3	3.175	0.1250	6.350	0.2500	-	-	2.380	0.0937	0.08	0.003	0.0124	31	89	169
SR2-5X2	3.175	0.1250	7.938	0.3125	-	-	2.779	0.1094	0.08	0.003	0.0234	44	89	254
SR154X1	3.175	0.1250	7.938	0.3125	-	-	2.779	0.1094	0.08	0.003	0.0124	31	89	169
SR2-5	3.175	0.1250	7.938	0.3125	2.779	0.1094	3.571	0.1406	0.08	0.003	0.0234	44	89	254
SR2X52	3.175	0.1250	9.525	0.3750	-	-	2.779	0.1094	0.15	0.006	0.0171	31	89	169
SR2-6	3.175	0.1250	9.525	0.3750	2.779	0.1094	3.571	0.1406	0.15	0.006	0.0273	71	133	356
SR164X3	3.175	0.1250	9.525	0.3750	-	-	2.380	0.0937	0.08	0.003	0.0124	31	89	169
SR2	3.175	0.1250	9.525	0.3750	3.967	0.1562	3.967	0.1562	0.30	0.012	0.0273	44	102	294
SR174X5	3.175	0.1250	10.414	0.4100	-	-	2.380	0.0937	0.08	0.003	0.0124	31	89	169
SR174X2	3.175	0.1250	10.795	0.4250	-	-	2.779	0.1094	0.15	0.006	0.0171	44	111	200
SR184X2	3.175	0.1250	12.700	0.5000	-	-	2.779	0.1094	0.08	0.003	0.0124	31	89	169
SR2A	3.175	0.1250	12.700	0.5000	4.366	0.1719	4.366	0.1719	0.30	0.012	0.0273	44	102	294
SR1204X1	3.175	0.1250	19.050	0.7500	-	-	3.175	0.1250	0.13	0.005	0.0310	89	196	387
SR155	3.967	0.1562	7.938	0.3125	2.779	0.1094	3.175	0.1250	0.08	0.003	0.0171	44	111	200
SR156*	4.762	0.1875	7.938	0.3125	2.779	0.1094	3.175	0.1250	0.08	0.003	0.0171	44	111	200
SR156X1	4.762	0.1875	7.938	0.3125	-	-	2.779	0.1094	0.08	0.003	0.0171	44	111	200
SR166*	4.762	0.1875	9.525	0.3750	3.175	0.1250	3.175	0.1250	0.08	0.003	0.0312	89	196	387
SR186X3	4.762	0.1875	12.700	0.5000	-	-	2.779	0.1094	0.13	0.005	0.0312	89	196	387
SR186X2	4.762	0.1875	12.700	0.5000	-	-	3.967	0.1562	0.13	0.005	0.0312	89	196	387
SR3	4.762	0.1875	12.700	0.5000	3.967	0.1562	4.978	0.1960	0.30	0.012	0.0615	120	218	614
SR3X8	4.762	0.1875	19.050	0.7500	-	-	4.978	0.1960	0.30	0.012	0.0615	120	218	614

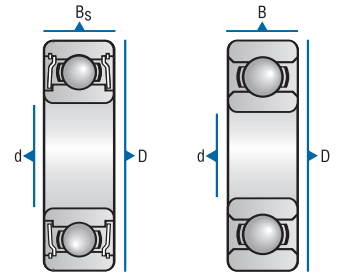
\*Also available with extended inner ring.






# DEEP GROOVE INSTRUMENT (INCH)

**Bore Diameters: 1.191mm to 4.762mm**

- Open, shielded and sealed



BASIC BEARING NUMBER	BEARING NOMENCLATURE			ATTAINABLE SPEEDS (RPM) BY CAGE OPTION** (see page 78)			
				Standard Snap In Cage	2-Piece Ribbon Cage	TA Cage	
	Open	Shielded	Flexeal			Oil	Grease
SR0	SR0	SR0SS	–	–	180,000	–	–
SR1	SR1	SR1SS	–	–	140,000	–	–
SR1-4	SR1-4	SR1-4SS	–	100,000	100,000	220,000	220,000
SR133	SR133	SR133SS	–	105,000	105,000	200,000	200,000
SR143	SR143	SR143SS	–	80,000	80,000	220,000	220,000
SR1-5	SR1-5	SR1-5SS	–	75,000	–	200,000	200,000
SR144	SR144	SR144SS	–	80,000	80,000	220,000	220,000
SR144X3	–	SR144SSX3	–	80,000	80,000	220,000 <sup>††</sup>	220,000 <sup>††</sup>
SR2-5X2	–	SR2-5SX2 <sup>††</sup>	–	75,000	75,000	–	–
SR154X1	–	SR154SSX1	–	80,000	80,000	220,000	220,000
SR2-5	SR2-5	SR2-5SS	SR2-5FF	75,000	75,000	200,000	200,000
SR2X52	–	SR2SSX52	–	70,000	70,000	–	–
SR2-6	SR2-6	SR2-6SS	–	65,000	65,000	–	–
SR164X3	–	SR164SSX3	–	80,000	80,000	220,000	220,000
SR2	SR2	SR2SS	SR2FF	65,000	65,000	160,000	160,000
SR174X5	–	SR174SSX5	–	70,000	70,000	200,000 <sup>††</sup>	200,000 <sup>††</sup>
SR174X2	–	SR174SSX2	–	70,000	70,000	220,000 <sup>††</sup>	220,000 <sup>††</sup>
SR184X2	–	SR184SSX2	–	80,000	80,000	200,000	200,000
SR2A	SR2A	SR2ASS	SR2AFF	50,000	50,000	140,000	140,000
SR1204X1	–	SR1204SSX1	–	50,000	50,000	–	–
SR155	SR155	SR155SS	–	55,000	55,000	150,000	150,000
SR156	SR156	SR156SS	–	55,000	55,000	150,000	150,000
SR156X1	–	SR156SX1 <sup>††</sup>	–	–	55,000	–	–
SR166	SR166	SR166SS	–	50,000	50,000	108,000 <sup>††</sup>	108,000 <sup>††</sup>
SR186X3	–	SR186SX3 <sup>††</sup>	–	50,000	50,000	–	–
SR186X2	–	SR186SSX2	–	50,000	50,000	–	–
SR3	SR3 <sup>†</sup>	SR3SS <sup>†</sup>	SR3FF	45,000	45,000	135,000	135,000
SR3X8	–	SR3SSX8	–	45,000	45,000	135,000	135,000

\*\*Attainable speed is determined by cage, not lubricant type. <sup>†</sup>Also available with T-Cage option. <sup>††</sup>Available only with single shield.

Tables continued on next page





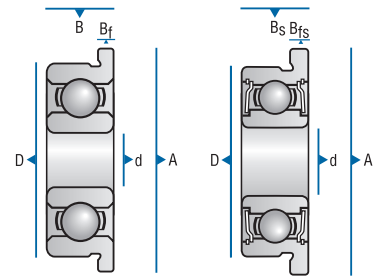




# DEEP GROOVE FLANGED (INCH)

**Bore Diameters: 1.191mm to 9.525mm**

- Open, shielded and sealed



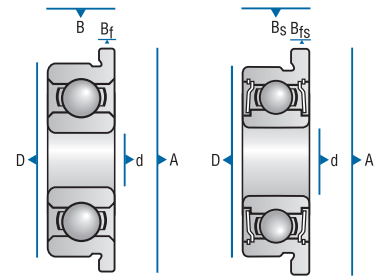
BASIC BEARING NUMBER	Bore Diameter d		Outside Diameter D		Width				Maximum Shaft/Housing Radius Which Bearing Corner Will Clear		Flange Diameter A		Flange Width				nd <sup>2</sup>
	mm	inch	mm	inch	B	inch	B <sub>S</sub>	inch	r Max.	inch	mm	inch	B <sub>f</sub>	inch	B <sub>fs</sub>	mm	
SFR0	1.191	0.0469	3.967	0.1562	1.588	0.0625	2.380	0.0937	0.08	0.003	5.160	0.203	0.330	0.013	0.790	0.031	0.0059
SFR1	1.397	0.0550	4.762	0.1875	1.984	0.0781	2.779	0.1094	0.08	0.003	5.940	0.234	0.580	0.023	0.790	0.031	0.0093
SFR1-4	1.984	0.0781	6.350	0.2500	2.380	0.0937	3.571	0.1406	0.08	0.003	7.520	0.296	0.580	0.023	0.790	0.031	0.0124
SFR133*	2.380	0.0937	4.762	0.1875	1.588	0.0625	2.380	0.0937	0.08	0.003	5.940	0.234	0.460	0.018	0.790	0.031	0.0078
SFR1-5	2.380	0.0937	7.938	0.3125	2.779	0.1094	3.571	0.1406	0.08	0.003	9.120	0.359	0.580	0.023	0.790	0.031	0.0234
SFR144*	3.175	0.1250	6.350	0.2500	2.380	0.0937	2.779	0.1094	0.08	0.003	7.520	0.296	0.580	0.023	0.790	0.031	0.0124
SFR2-5	3.175	0.1250	7.938	0.3125	2.779	0.1094	3.571	0.1406	0.08	0.003	9.120	0.359	0.580	0.023	0.790	0.031	0.0234
SFR2-6	3.175	0.1250	9.525	0.3750	2.779	0.1094	3.571	0.1406	0.15	0.006	10.720	0.422	0.580	0.023	0.790	0.031	0.0273
SFR2	3.175	0.1250	9.525	0.3750	3.967	0.1562	3.967	0.1562	0.30	0.012	11.180	0.440	0.760	0.030	0.760	0.030	0.0273
SFR155	3.967	0.1562	7.938	0.3125	2.779	0.1094	3.175	0.1250	0.08	0.003	9.120	0.359	0.580	0.023	0.910	0.036	0.1710
SFR156*	4.762	0.1875	7.938	0.3125	2.779	0.1094	3.175	0.1250	0.08	0.003	9.120	0.359	0.580	0.023	0.910	0.036	0.0171
SFR166*	4.762	0.1875	9.525	0.3750	3.175	0.1250	3.175	0.1250	0.08	0.003	10.720	0.422	0.580	0.023	0.790	0.031	0.0312
SFR3X3	4.762	0.1875	12.700	0.5000	3.967	0.1562	-	-	0.30	0.012	14.350	0.565	1.070	0.042	-	-	0.0615
SFR3	4.762	0.1875	12.700	0.5000	4.978	0.1960	4.978	0.1960	0.30	0.012	14.350	0.565	1.070	0.042	1.070	0.042	0.0615
SFR168	6.350	0.2500	9.525	0.3750	3.175	0.1250	3.175	0.1250	0.08	0.003	10.720	0.422	0.580	0.023	0.910	0.036	0.0171
SFR188*	6.350	0.2500	12.700	0.5000	3.175	0.1250	4.762	0.1875	0.13	0.005	13.890	0.547	0.580	0.023	1.140	0.045	0.0430
SFR4	6.350	0.2500	15.875	0.6250	4.978	0.1960	4.978	0.1960	0.30	0.012	17.530	0.690	1.070	0.042	1.070	0.042	0.0703
SFR1810	7.938	0.3125	12.700	0.5000	3.967	0.1562	3.967	0.1562	0.13	0.005	13.890	0.547	0.790	0.031	0.790	0.031	0.0430
SFR6	9.525	0.3750	22.225	0.8750	7.142	0.2812	7.142	0.2812	0.41	0.016	24.610	0.969	1.570	0.062	1.570	0.062	0.1710

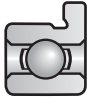
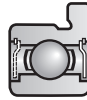

\*Also available with extended inner ring.

# DEEP GROOVE FLANGED (INCH)

**Bore Diameters: 1.191mm to 9.525mm**

- Open, shielded and sealed



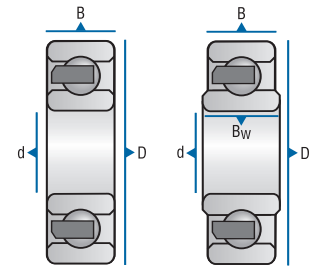
BASIC BEARING NUMBER	Static Capacity		Basic Dynamic Load Rating C (N)	BEARING NOMENCLATURE			ATTAINABLE SPEEDS (RPM) BY CAGE OPTION** (see page 78)			
				 Open	 Shielded	 Flexeal	Standard Snap In Cage	2-Piece Ribbon Cage	TA Cage	
	Oil	Grease								
SFR0	13	36	85	SFR0	SFROSS	–	–	180,000	–	–
SFR1	22	53	129	SFR1	SFR1SS	–	–	140,000	–	–
SFR1-4	31	89	169	SFR1-4	SFR1-4SS	–	100,000	100,000	220,000	220,000
SFR133	18	58	111	SFR133	SFR133SS	–	105,000	105,000	216,000	216,000
SFR1-5	44	89	254	SFR1-5	SFR1-5SS	–	75,000	75,000	200,000	200,000
SFR144	31	89	169	SFR144	SFR144SS	–	80,000	80,000	220,000	220,000
SFR2-5	44	89	254	SFR2-5	SFR2-5SS	SFR2-5FF	75,000	75,000	200,000	200,000
SFR2-6	71	133	356	SFR2-6	SFR2-6SS	–	65,000	65,000	160,000	160,000
SFR2	44	102	294	SFR2	SFR2SS	SFR2FF	65,000	65,000	160,000	160,000
SFR155	44	111	200	SFR155	SFR155SS	–	55,000	55,000	150,000	150,000
SFR156	44	111	200	SFR156	SFR156SS	–	55,000	55,000	150,000	150,000
SFR166	89	196	387	SFR166	SFR166SS	–	50,000	50,000	140,000 <sup>††</sup>	140,000 <sup>††</sup>
SFR3X3	120	218	614	SFR3X3	–	–	45,000	45,000	–	–
SFR3	120	218	614	SFR3 <sup>†</sup>	SFR3SS <sup>†</sup>	SFR3FF	45,000	45,000	135,000	135,000
SFR168	36	98	169	SFR168	SFR168SS	–	48,000	–	–	–
SFR188	120	254	471	SFR188	SFR188SS	–	–	42,000	110,000	110,000
SFR4	156	280	694	SFR4 <sup>†</sup>	SFR4SS <sup>†</sup>	SFR4FF	40,000	40,000	105,000	105,000
SFR1810	120	249	463	SFR1810	SFR1810SS	–	–	32,000	–	–
SFR6	383	574	1579	SFR6	SFR6SS	SFR6FF	–	24,000	55,000	55,000

\*\*Attainable speed is determined by cage, not lubricant type. <sup>†</sup>Also available with T-Cage option. <sup>††</sup>Available only with single shield.

# DEEP GROOVE THIN SECTION (INCH)

**Bore Diameters: 15.875mm to 39.688mm**

- Open, shielded and sealed



500 SERIES  BASIC BEARING NUMBER	Bore Diameter d		Outside Diameter D		Width Outer Ring B		Width Inner Ring Bw		Maximum Shaft/Housing Radius Which Bearing Corner Will Clear		nd <sup>2</sup>	Static Capacity		Basic Dynamic Load Rating C (N)
	mm	inch	mm	inch	mm	inch	mm	inch	r Max. mm	inch		Radial C <sub>0</sub> (N)	Thrust T <sub>0</sub> (N)	
SN538ZA	15.875	0.6250	26.988	1.0625	6.350	0.2500	6.350	0.2500	0.38	0.015	0.1406	641	1,526	1,659
SN538TA	15.875	0.6250	26.988	1.0625	6.350	0.2500	6.350	0.2500	0.38	0.015	0.1875	836	2,033	1,988
A538ZA	15.875	0.6250	26.988	1.0625	6.350	0.2500	7.142	0.2812	0.38	0.015	0.1406	1,379	1,054	2,064
A538T	15.875	0.6250	26.988	1.0625	6.350	0.2500	7.142	0.2812	0.38	0.015	0.1563	1,005	1,103	2,193
SN539ZA	19.050	0.7500	30.163	1.1875	6.350	0.2500	6.350	0.2500	0.38	0.015	0.1719	787	1,926	1,859
SN539TA	19.050	0.7500	30.163	1.1875	6.350	0.2500	6.350	0.2500	0.38	0.015	0.2188	1,014	2,451	2,148
A539ZA	19.050	0.7500	30.163	1.1875	6.350	0.2500	7.142	0.2812	0.38	0.015	0.1719	1,139	1,232	2,300
A539T	19.050	0.7500	30.163	1.1875	6.350	0.2500	7.142	0.2812	0.38	0.015	0.1875	1,245	1,343	2,438
SN540ZA	22.225	0.8750	33.338	1.3125	6.350	0.2500	6.350	0.2500	0.38	0.015	0.2031	961	2,335	2,028
SN540TA	22.225	0.8750	33.338	1.3125	6.350	0.2500	6.350	0.2500	0.38	0.015	0.2188	1,606	2,669	2,153
A540ZA	22.225	0.8750	33.338	1.3125	6.350	0.2500	7.142	0.2812	0.38	0.015	0.2031	1,388	1,468	2,518
A540T	22.225	0.8750	33.338	1.3125	6.350	0.2500	7.142	0.2812	0.38	0.015	0.2188	1,495	1,575	2,651
SN541ZA	26.988	1.0625	38.100	1.5000	6.350	0.2500	6.350	0.2500	0.38	0.015	0.2344	1,139	2,771	2,153
SN541TA	26.988	1.0625	38.100	1.5000	6.350	0.2500	6.350	0.2500	0.38	0.015	0.2813	2,122	3,398	2,455
A541ZA	26.988	1.0625	38.100	1.5000	6.350	0.2500	7.142	0.2812	0.38	0.015	0.2344	1,632	1,672	2,682
A541T	26.988	1.0625	38.100	1.5000	6.350	0.2500	7.142	0.2812	0.38	0.015	0.2500	1,744	1,784	2,798
SN542ZA	33.338	1.3125	44.450	1.7500	6.350	0.2500	6.350	0.2500	0.38	0.015	0.2969	1,481	3,607	2,406
SN542TA	33.338	1.3125	44.450	1.7500	6.350	0.2500	6.350	0.2500	0.38	0.015	0.3125	2,411	3,727	2,518
A542ZA	33.338	1.3125	44.450	1.7500	6.350	0.2500	7.142	0.2812	0.38	0.015	0.2969	2,126	2,104	3,016
A542T	33.338	1.3125	44.450	1.7500	6.350	0.2500	7.142	0.2812	0.38	0.015	0.2813	2,015	1,993	2,909
SN543ZA	39.688	1.5625	50.800	2.0000	6.350	0.2500	6.350	0.2500	0.38	0.015	0.3438	1,739	4,252	2,522
SN543TA	39.688	1.5625	50.800	2.0000	6.350	0.2500	6.350	0.2500	0.38	0.015	0.4060	3,211	4,915	2,851
A543ZA	39.688	1.5625	50.800	2.0000	6.350	0.2500	7.142	0.2812	0.38	0.015	0.3438	2,500	2,451	3,207
A543T	39.688	1.5625	50.800	2.0000	6.350	0.2500	7.142	0.2812	0.38	0.015	0.3438	2,500	2,451	3,207





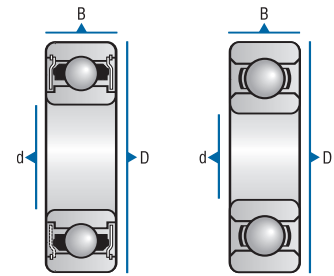




# DEEP GROOVE SPINDLE AND TURBINE (METRIC)

**Bore Diameters: 10mm to 25mm**

- Open, shielded and sealed

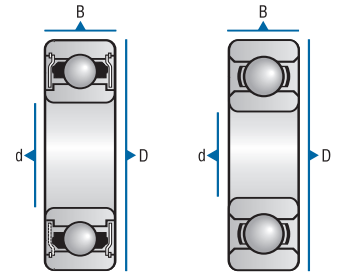






BASIC BEARING NUMBER	Bore Diameter d		Outside Diameter D		Width B		Maximum Shaft/Housing Radius Which Bearing Corner Will Clear		nd <sup>2</sup>	Static Capacity		Basic Dynamic Load Rating C (kN)
	mm	inch	mm	inch	mm	inch	r Max. mm	inch		Radial C <sub>0</sub> (kN)	Thrust T <sub>0</sub> (kN)	
100	10.000	0.3937	26.000	1.0236	8.000	0.3150	0.30	0.012	0.246	2.79	1.51	4.45
100X1	10.000	0.3937	26.000	1.0236	11.510	0.4531	0.30	0.012	0.246	1.71	2.10	4.53
200	10.000	0.3937	30.000	1.1811	9.000	0.3543	0.64	0.025	0.335	3.09	2.32	5.90
101	12.000	0.4724	28.000	1.1024	8.000	0.3150	0.30	0.012	0.281	2.16	2.29	5.00
101X1	12.000	0.4724	28.000	1.1024	11.510	0.4531	0.30	0.012	0.281	3.38	1.79	4.94
101X1	12.000	0.4724	28.000	1.1024	11.510	0.4531	0.30	0.012	0.281	3.38	1.79	4.94
201	12.000	0.4724	32.000	1.2598	10.000	0.3937	0.64	0.025	0.385	3.59	2.52	6.72
9201	12.000	0.4724	32.000	1.2598	15.875	0.6250	0.64	0.025	0.385	3.59	2.52	6.72
201X1	13.000	0.5118	32.000	1.2598	12.700	0.5000	0.64	0.025	0.385	3.59	2.52	6.72
1902X1	15.000	0.5906	28.000	1.1024	7.000	0.2756	0.30	0.012	0.218	2.23	1.95	3.50
102	15.000	0.5906	32.000	1.2598	9.000	0.3543	0.30	0.012	0.316	3.29	2.93	5.44
202	15.000	0.5906	35.000	1.3780	11.000	0.4331	0.64	0.025	0.438	4.17	3.13	7.62
202	15.000	0.5906	35.000	1.3780	11.000	0.4331	0.64	0.025	0.438	4.17	3.13	7.62
202X1	15.000	0.5906	35.000	1.3780	12.700	0.5000	0.64	0.025	0.438	4.17	3.13	7.62
9302X1	15.000	0.5906	35.000	1.3780	19.000	0.7501	1.00	0.040	0.438	4.17	3.13	7.62
103	17.000	0.6693	35.000	1.3780	10.000	0.3937	0.30	0.012	0.352	4.56	2.12	5.74
203	17.000	0.6693	40.000	1.5748	12.000	0.4724	0.64	0.025	0.565	5.60	4.85	9.39
203	17.000	0.6693	40.000	1.5748	12.000	0.4724	0.64	0.025	0.565	5.60	4.85	9.39
9203	17.000	0.6693	40.000	1.5748	17.460	0.6945	0.64	0.025	0.565	5.60	4.85	9.39
104	20.000	0.7874	42.000	1.6535	12.000	0.4724	0.64	0.025	0.563	6.48	4.19	9.23
204	20.000	0.7874	47.000	1.8504	14.000	0.5512	1.00	0.040	0.781	7.77	6.73	12.63
204	20.000	0.7874	47.000	1.8504	14.000	0.5512	1.00	0.040	0.781	7.77	6.73	12.63
9204	20.000	0.7874	47.000	1.8504	20.640	0.8125	1.00	0.040	0.781	7.77	6.73	12.63
9204	20.000	0.7874	47.000	1.8504	20.640	0.8125	1.00	0.040	0.781	7.77	6.73	12.63
105	25.000	0.9843	47.000	1.8504	12.000	0.4724	0.64	0.025	0.625	6.77	9.20	9.80
205	25.000	0.9843	52.000	2.0472	15.000	0.5906	1.00	0.040	0.879	9.10	7.75	13.78
205	25.000	0.9843	52.000	2.0472	15.000	0.5906	1.00	0.040	0.879	9.10	7.75	13.78
9205	25.000	0.9843	52.000	2.0472	20.640	0.8125	1.00	0.040	0.879	9.10	7.75	13.78

# DEEP GROOVE SPINDLE AND TURBINE (METRIC)

**Bore Diameters: 10mm to 25mm**

- Open, shielded and sealed



BASIC BEARING NUMBER	BEARING NOMENCLATURE				ATTAINABLE SPEEDS (RPM) BY CAGE OPTION (see page 78)			
					2-Piece Ribbon Cage*	TMT Cage*	T Cage	
	Open	Shielded	Sealed	Flexeal			Oil	Grease
100	100	100SS	–	–	26,500	–	–	–
100X1	–	100SS(T)X1	–	100FF(T)X1	26,500	–	106,000	85,000
200	200(T)	200SS	–	200FF	25,000	–	100,000	85,000
101	101T	–	–	–	–	–	89,000	70,833
101X1	–	101SSTX1	–	101FFTXX1	–	–	89,000	70,833
101X1	–	101SSTMTX1	–	101FFTMTX1	–	26,500	–	–
201	201(T)	201SS	201VV	201FF	20,500	–	83,000	70,833
9201	9201(T)	9201SS(T)	9201VV(T)	9201FF(T)	20,500	–	83,000	70,833
201X1	201(T)X1	201SS(T)X1	201VV(T)X1	201FF(T)X1	20,500	–	83,000	65,385
1902X1	1902TX1	–	–	1902FFTXX1	–	–	67,000	56,667
102	102T	102SSTMT	–	102FFTMT	–	20,000	71,000	56,667
202	202(T)	202SS(T)	202YY	202FF(T)	16,800	–	67,000	56,667
202	202TMT	202SSTMT	202YYTMT	202FFTMT	–	20,000	–	–
202X1	202(T)X1	202SS(T)X1	–	202FF(T)X1	16,800	–	67,000	56,667
9302X1	9302TX1	–	–	9302FFTXX1	–	–	67,000	56,667
103	103(T)	103SS(T)	–	103FF(T)	15,400	–	62,000	50,000
203	203(T)	203SS(T)	203YY	203FF(T)	14,800	–	59,000	50,000
203	203TMT	203SSTMT	–	203FFTMT	–	17,600	–	–
9203	9203(T)	9203SS(T)	9203VV(T)	9203FF(T)	14,800	–	59,000	50,000
104	104T	104SST	–	104FFT	–	–	53,000	42,500
204	204(T)	204SS(T)	204YY(T)	204FF(T)	12,500	–	50,000	42,500
204	204TMT	204SSTMT	204YYTMT	204FFTMT	–	15,000	–	–
9204	9204(T)	9204SS(T)	9204VV(T)	9204FF(T)	12,500	–	50,000	42,500
9204	9204TMT	9204SSTMT	9204VVTMT	9204FFTMT	–	15,000	–	–
105	105T	105SST	–	105FFT	–	–	42,500	34,000
205	205(T)	205SS(T)	205YY(T)	205FF(T)	10,000	–	40,000	34,000
205	205TMT	205SSTMT	205YYTMT	205FFTMT	–	12,000	–	–
9205	9205(T)	9205SS(T)	9205VV(T)	9205FF(T)	10,000	–	40,000	34,000

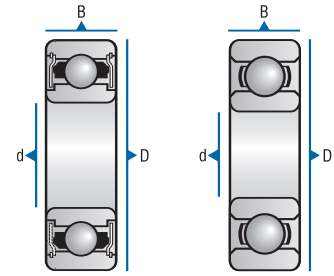
\*Attainable speed is determined by cage, not lubricant type.

Tables continued on next page

# DEEP GROOVE SPINDLE AND TURBINE (METRIC)

**Bore Diameters: 25mm to 45mm**

- Open, shielded and sealed

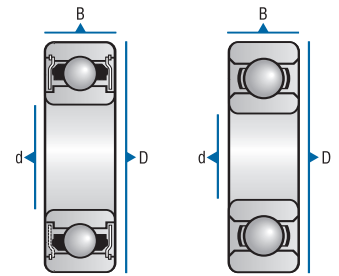






BASIC BEARING NUMBER	Bore Diameter d		Outside Diameter D		Width B		Maximum Shaft/Housing Radius Which Bearing Corner Will Clear		nd <sup>2</sup>	Static Capacity		Basic Dynamic Load Rating C (kN)
	mm	inch	mm	inch	mm	inch	r Max. mm	inch		Radial C <sub>0</sub> (kN)	Thrust T <sub>0</sub> (kN)	
9205	25.000	0.9843	52.000	2.0472	20.640	0.8125	1.00	0.040	0.879	9.10	7.75	13.78
305	25.000	0.9843	62.000	2.4409	17.000	0.6693	1.00	0.040	1.340	12.73	18.58	20.99
9305	25.000	0.9843	62.000	2.4409	39.370	1.0000	1.00	0.040	1.340	12.73	18.58	20.99
106	30.000	1.1811	55.000	2.1654	13.000	0.5118	1.00	0.040	0.870	9.57	8.02	12.98
206	30.000	1.1811	62.000	2.4409	16.000	0.6299	1.00	0.040	1.270	13.09	11.16	19.07
206	30.000	1.1811	62.000	2.4409	16.000	0.6299	1.00	0.040	1.270	13.09	11.16	19.07
9206	30.000	1.1811	62.000	2.4409	23.810	0.9375	1.00	0.040	1.270	13.09	11.16	19.07
9206	30.000	1.1811	62.000	2.4409	23.810	0.9375	1.00	0.040	1.270	13.09	11.16	19.07
107	35.000	1.3780	62.000	2.4409	14.000	0.5512	1.00	0.040	1.074	11.69	15.21	15.72
207	35.000	1.3780	72.000	2.8346	17.000	0.6693	1.00	0.040	1.723	17.81	20.59	25.26
207	35.000	1.3780	72.000	2.8346	17.000	0.6693	1.00	0.040	1.723	17.81	20.59	25.26
9207	35.000	1.3780	72.000	2.8346	26.990	1.0625	1.00	0.040	1.723	17.81	20.59	25.26
9207	35.000	1.3780	72.000	2.8346	26.990	1.0625	1.00	0.040	1.723	17.81	20.59	25.26
307	35.000	1.3780	80.000	3.1496	21.000	0.8268	1.50	0.060	2.215	21.31	30.96	33.17
307	35.000	1.3780	80.000	3.1496	21.000	0.8268	1.50	0.060	2.215	21.31	30.96	33.17
9307	35.000	1.3780	80.000	3.1496	34.920	1.3757	1.50	0.060	2.215	21.31	30.96	33.17
9307	35.000	1.3780	80.000	3.1496	34.920	1.3750	1.50	0.060	2.215	21.31	30.96	33.17
108	40.000	1.5748	68.000	2.6772	15.000	0.5906	1.00	0.040	1.172	13.41	12.71	16.35
208	40.000	1.5748	80.000	3.1496	18.000	0.7087	1.00	0.040	1.978	20.72	26.87	28.64
208	40.000	1.5748	80.000	3.1496	18.000	0.7087	1.00	0.040	1.978	20.72	26.87	28.64
9208	40.000	1.5748	80.000	3.1496	30.160	1.1875	1.00	0.040	1.978	20.72	26.87	28.64
9208	40.000	1.5748	80.000	3.1496	30.160	1.1875	1.00	0.040	1.978	20.72	26.87	28.64
308	40.000	1.5748	90.000	3.1496	23.000	0.9055	1.50	0.060	3.125	30.74	43.00	44.08
9308	40.000	1.5748	90.000	3.1496	36.510	1.4375	1.50	0.060	3.125	30.74	43.00	44.08
109	45.000	1.7717	75.000	2.9578	16.000	0.6299	1.00	0.040	1.547	17.32	23.22	21.47
209	45.000	1.7717	85.000	3.3465	19.000	0.7480	1.00	0.040	2.197	23.57	23.23	30.66
209	45.000	1.7717	85.000	3.3465	19.000	0.7480	1.00	0.040	2.197	23.57	23.23	30.66
9209	45.000	1.7717	85.000	3.3465	30.160	1.1875	1.00	0.040	2.197	23.57	23.23	30.66

# DEEP GROOVE SPINDLE AND TURBINE (METRIC)

**Bore Diameters: 25mm to 45mm**

- Open, shielded and sealed



BASIC BEARING NUMBER	BEARING NOMENCLATURE				ATTAINABLE SPEEDS (RPM) BY CAGE OPTION (see page 78)			
					2-Piece Ribbon Cage*	TMT Cage*	T Cage	
	Open	Shielded	Sealed	Flexeal			Oil	Grease
9205	9205TMT	9205SSTMT	9205VVTMT	9205FFTMT	–	12,000	–	–
305	305T	305SST	–	305FFT	–	–	40,000	34,000
9305	9305T	9305SST	–	9305FFT	–	–	40,000	34,000
106	106T	106SST	–	106FFT	–	–	35,000	28,333
206	206(T)	206SS(T)	206VV(T)	206FF(T)	8,400	–	33,500	28,333
206	206TMT	206SSTMT	206VVTMT	206FFTMT	–	10,000	–	–
9206	9206(T)	9206SS(T)	9206VV(T)	9206FF(T)	8,400	–	33,500	28,333
9206	9206TMT	9206SSTMT	9206VVTMT	9206FFTMT	–	10,000	–	–
107	107T	107SST	–	107FFT	–	–	30,500	24,286
207	207(T)	207SS(T)	–	207FF(T)	7,100	–	28,500	24,286
207	207TMT	207SSTMT	–	207FFTMT	–	8,500	–	–
9207	9207(T)	9207SS(T)	–	9207FF(T)	7,100	–	28,500	24,286
9207	9207TMT	9207SSTMT	–	9207FFTMT	–	8,500	–	–
307	307T	307SST	–	307FFT	–	–	28,500	24,286
307	307TMT	307SSTMT	–	307FFTMT	–	6,900	–	–
9307	9307T	9307SST	–	9307FFT	–	–	28,500	24,286
9307	9307TMT	9307SSTMT	–	9307FFTMT	–	6,900	–	–
108	108T	108SST	–	–	–	–	27,000	21,250
208	208T	208SST	208VVT	208FFT	–	–	25,000	21,250
208	208TMT	208SSTMT	208YYTMT	208FFTMT	–	7,500	–	–
9208	9208T	9208SST	9208VVT	9208FFT	–	–	25,000	21,250
9208	9208TMT	9208SSTMT	9208YYTMT	9208FFTMT	–	7,500	–	–
308	308TMT	308SSTMT	–	–	–	6,000	–	–
9308	9308TMT	9308SSTMT	–	–	–	6,000	–	–
109	109TMT	–	–	109FFTMT	–	7,000	–	–
209	209T	209SST	–	–	–	–	23,000	18,889
209	209TMT	209SSTMT	–	–	–	6,700	–	–
9209	9209T	9209SST	–	–	–	–	23,000	18,889

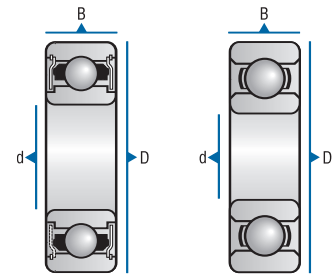
\*Attainable speed is determined by cage, not lubricant type.

Tables continued on next page

# DEEP GROOVE SPINDLE AND TURBINE (METRIC)

**Bore Diameters: 45mm to 160mm**

- Open, shielded and sealed



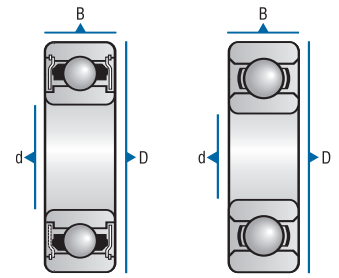
BASIC BEARING NUMBER	Bore Diameter d		Outside Diameter D		Width B		Maximum Shaft/Housing Radius Which Bearing Corner Will Clear		nd <sup>2</sup>	Static Capacity		Basic Dynamic Load Rating C (kN)
	mm	inch	mm	inch	mm	inch	r Max. mm	inch		Radial C <sub>0</sub> (kN)	Thrust T <sub>0</sub> (kN)	
9209	45.000	1.7717	85.000	3.3465	30.160	1.1875	1.00	0.040	2.197	23.57	23.23	30.66
309	45.000	1.7717	100.000	3.9370	25.000	0.9843	1.50	0.060	3.781	37.22	52.91	51.89
9309	45.000	1.7717	100.000	3.9370	39.690	1.5625	1.50	0.060	3.781	37.22	52.91	51.89
110	50.000	1.9685	80.000	3.1496	16.000	0.6299	1.00	0.040	1.828	20.90	20.65	23.80
210	50.000	1.9685	90.000	3.5433	20.000	0.7874	1.00	0.040	2.500	26.87	26.57	34.40
310	50.000	1.9685	110.000	4.3307	27.000	1.0630	2.00	0.080	4.500	44.51	63.27	60.76
9310	50.000	1.9685	110.000	4.3307	44.450	1.7500	1.00	0.040	4.500	44.51	63.27	60.76
111	55.000	2.1654	90.000	3.5433	18.000	0.7807	1.00	0.040	2.297	25.91	28.41	29.89
211	55.000	2.1654	100.000	3.9370	21.000	0.8268	1.50	0.060	3.164	33.81	46.54	40.09
311	55.000	2.1654	120.000	4.7244	29.000	1.1417	2.00	0.080	5.281	52.46	75.39	70.26
312	60.000	2.3622	130.000	5.1181	31.000	1.2205	2.00	0.080	6.125	61.03	86.32	80.35
9312	60.000	2.3622	130.000	5.1181	53.975	2.1250	2.00	0.080	6.125	61.03	86.32	80.35
313	65.000	2.5591	140.000	5.5118	33.000	1.2992	2.00	0.080	7.031	70.27	99.53	91.98
313	65.000	2.5591	140.000	5.5118	33.000	1.2992	2.00	0.080	7.031	70.27	99.53	91.98
9313	65.000	2.5591	140.000	5.5118	58.740	2.3125	2.00	0.080	7.031	70.27	99.53	91.98
9313	65.000	2.5591	140.000	5.5118	58.740	2.3125	2.00	0.080	7.031	70.27	99.53	91.98
314	70.000	2.7559	150.000	5.9055	35.000	1.3780	2.00	0.080	8.000	76.71	114.48	103.29
9314	70.000	2.7559	150.000	5.9055	63.500	2.5000	2.00	0.080	8.000	76.71	114.48	103.29
315	75.000	2.9528	160.000	6.2992	37.000	1.4567	2.00	0.080	9.031	86.90	81.32	115.34
316	80.000	3.1496	170.000	6.6929	39.000	1.5354	2.00	0.080	9.031	92.90	129.64	116.02
317	85.000	3.3465	180.000	7.0866	29.000	1.6142	2.50	0.100	10.125	104.19	145.14	128.46
318	90.000	3.5433	190.000	7.4803	43.000	1.6929	2.50	0.100	11.281	116.14	161.80	140.03
320	100.000	3.9370	215.000	8.4646	47.000	1.8504	3.00	0.120	15.125	147.81	218.75	184.16
222	110.000	4.3307	200.000	7.8740	38.000	1.4961	2.00	0.080	12.656	107.14	286.65	147.32
322	110.000	4.3307	240.000	9.4488	50.000	1.9685	3.00	0.120	18.000	184.61	260.84	214.34
232	160.000	6.2992	290.000	11.4173	48.000	1.8898	3.00	0.120	20.797	234.20	313.29	222.36







# DEEP GROOVE SPINDLE AND TURBINE (METRIC)

**Bore Diameters: 45mm to 160mm**

- Open, shielded and sealed



BASIC BEARING NUMBER	BEARING NOMENCLATURE				ATTAINABLE SPEEDS (RPM) BY CAGE OPTION (see page 78)			
					2-Piece Ribbon Cage*	TMT Cage*	T Cage	
	Open	Shielded	Sealed	Flexeal			Oil	Grease
9209	9209TMT	9209SSTMT	-	-	-	6,700	-	-
309	309TMT	309SSTMT	-	309FFTMT	-	5,300	-	-
9309TMT	9309TMT	9309SSTMT	-	-	-	5,300	-	-
110	110T	110SST	-	-	-	-	22,500	17,000
210	210T	-	-	-	-	-	20,000	17,000
310	310TMT	310SSTMT	-	310FFTMT	-	4,800	-	-
9310	9310TMT	9310SSTMT	-	9310FFTMT	-	4,800	-	-
111	111T	111SST	-	-	-	-	20,000	15,455
211	211TMT	-	-	-	-	5,500	-	-
311	311TMT	-	-	311FFTMT	-	4,400	-	-
312	312TMT	312SSTMT	-	-	-	4,000	-	-
9312	9312TMT	9312SSTMT	-	9312FFTMT	-	4,000	-	-
313	313T	313SST	-	313FFT	-	-	15,300	13,077
313	313TMT	313SSTMT	-	313FFTMT	-	3,700	-	-
9313	9313T	9313SST	-	9313FFT	-	-	15,300	13,077
9313	9313TMT	9313SSTMT	-	9313FFTMT	-	3,700	-	-
314	314TMT	314SSTMT	-	-	-	3,400	-	-
9314	9314TMT	9314SSTMT	-	-	-	3,400	-	-
315	315TMT	315SSTMT	-	-	-	3,200	-	-
316	316TMT	-	-	-	-	3,000	-	-
317	317TMT	-	-	-	-	2,800	-	-
318	318TMT	-	-	-	-	2,700	-	-
320	320TMT	-	-	-	-	2,400	-	-
222	222TMT	-	-	-	-	2,700	-	-
322	322TMT	-	-	-	-	2,200	-	-
232	232TMT	-	-	-	-	1,500	-	-

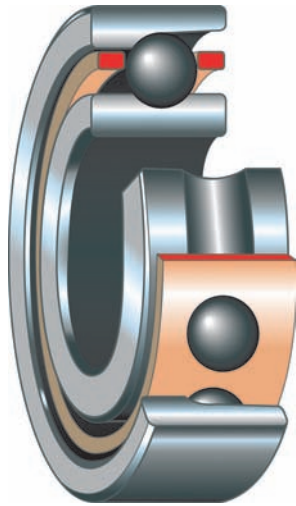
\*Attainable speed is determined by cage, not lubricant type.



# ANGULAR CONTACT BEARINGS



## ANGULAR CONTACT BEARINGS



### Angular Contact Bearing Design

Angular contact bearings have one ring shoulder removed, this may be from the inner or outer ring. This allows a larger ball complement than found in comparable deep groove bearings, giving a greater load capacity. Speed capacity of angular contact bearings is also greater than deep groove.

Barden angular contact bearings have a nominal contact angle ranging from  $10^{\circ}$  to  $25^{\circ}$ . They can be used in pre-loaded duplex sets, back to back (DB) or face to face (DF) for supporting thrust loads in both directions or in tandem (DT) for additional capacity.

Contact angles are obtained by assembling the bearings to the appropriate radial play values. The smaller contact angles give better radial capacity and rigidity while the higher contact angles give higher axial capacity and rigidity.

Angular contact bearings support thrust loads or combinations of radial and thrust loading. They can not accept radial loads alone – a thrust load of sufficient magnitude must be applied. A single angular contact bearing can be loaded in one thrust direction only, this may be an operating load or pre-load.

Separable and non-separable types are available within the category of angular contact bearings. Separable bearings are useful where bearings must be installed in blind holes or where press fits are required on the shaft and in the housing. The separable feature also permits dynamic balancing of the rotating components with the inner ring mounted in place without the outer ring and housing.

In Barden miniature and instrument angular contact bearings (types B and H), machined phenolic cages with high speed capability are standard. These cages are outer ring land guided, which allows lubricant access to the most desired point at the ring and ball contact area. Centrifugal force carries lubricant outwards during operation to reach the other areas of need.

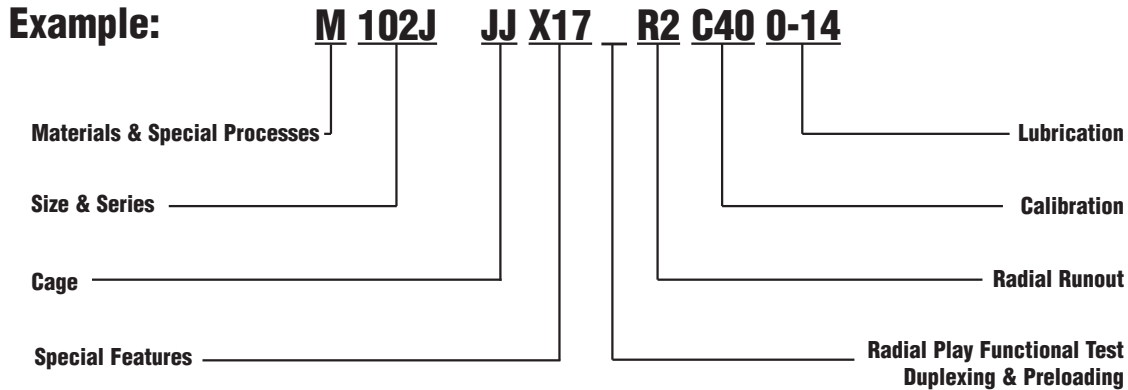
For larger spindle and turbine series B types, phenolic cages are also standard, but H types are normally supplied with bronze cages of various designs.

In separable bearings the B type cages have stepped ball pockets to retain the balls when the inner ring is removed.

Consult Barden engineering for questions regarding additional cage considerations, or refer to cage discussion in the engineering section.

# ANGULAR CONTACT BEARINGS

## Nomenclature



### Materials & Special Processes

- BC** – Barrier coating
  - P** – TCP coating
  - C** – Ceramic Balls
  - 30X** – 'X Life Ultra' rings
  - S** – AISI 440C rings and balls
  - M** – M50 rings and balls
  - T** – T5 rings and T15 balls
  - V** – Denotes Abec 5T for torque tube and extra thin series
- No symbol indicates SAE 52100 rings and balls

### Sizes & Series

- R\_B** – Inch series instrument angular contact bearing with separable relieved inner ring
- R\_H** – Inch series instrument angular contact bearing with non separable relieved outer ring
- 30B or H** – Metric series spindle/turbine configurations as for R series above
- 100B** – Metric series spindle turbine bearing with separable relieved inner ring
- 100/200/300/1900 H** – Metric series spindle/turbine angular contact non separable relieved outer ring
- 100/200/300/1900 J** – Metric series spindle/turbine angular contact non separable relieved inner ring

### Cages

- B** – Reinforced phenolic, one piece, designed to retain the balls in the outer ring
- H** – Reinforced phenolic, one piece, halo design
- (H)JB** – Bronze machined halo light weight design for optimum capacity
- (H)JH** – Bronze machined halo, heavier section, centered on ball pitch diameter
- (J)JJ** – Bronze pressed halo with formed pockets

### Special Features

Letters 'X' or 'Y' followed by numbers indicate special features. Some of these are now 'standard' and appear in the bearing tables. Some commonly used are:

- X204** – Customer part number marked on bearing
- X205** – Full of Balls (no cage)

Consult Barden Engineering for details.

### Radial Play

Radial play in angular contact bearings is usually standardised by the design either:

- to achieve a desired contact angle
- or
- to achieve optimum performance under the typical combined load whilst still remaining assembled for handling and mounting operations

### Functional Test

Angular contact bearings are not normally subject to special low torque testing.

### Duplexing & Preloads

For duplex sets, letter symbol indicates type of mounting. If followed by number, numerals indicate mean preload in pounds. Absence of number indicates standard preload.

- D** – Universal mounting. Angular contact duplex sets universally ground have inner and outer rings of the same width, and can be installed DB, DF or DT. Standard Preloads are indicated by: **L** – Light, **M** – Medium and **H** – Heavy.

### Radial Runout

- E** – Special radial runout consult Barden
- R** – Inner ring marked for high point of radial runout
- R1** – Outer ring marked for high point of radial runout
- R2** – Both rings marked with high point of radial runout

### Calibration

Bearings are available with bore and O/D calibrated into steps of 0.0001", 0.00005" or 0.001mm.

- C** – Bore and O/D in 0.0001" (0.0025mm) steps
- C44** – Bore & O/D in 0.00005" (0.00125mm) steps
- 0** – Is used when no calibration is required, i.e. **CX0** – bore only calibrated in 0.0001" steps

Groups may be combined, i.e.

- C4X** – Bore is calibrated in 0.00005" steps and O/D in 0.0001" steps
- CM** – Special metric calibration in 1 micron steps (0.001mm), inner ring bore only

For further information consult 'Calibration' in Engineering Section.

### Lubrication

The pre-lubrication type is always indicated within the bearing number on the packaging.

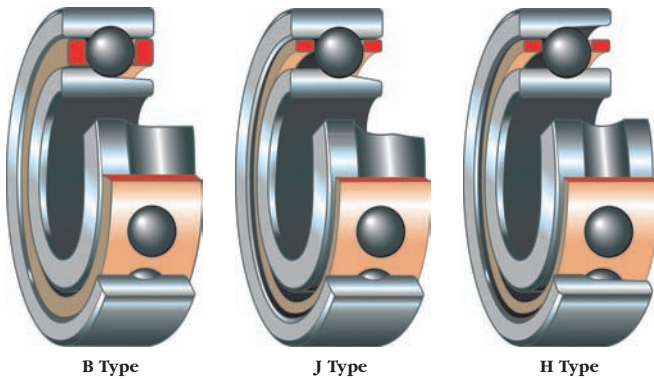
- O** or **OJ** numbers denote oil
- G** or **GJ** numbers denote grease

Popular lubricants are listed within 'Lubrication' in the Engineering Section.



# ANGULAR CONTACT BEARINGS

## Product Series Descriptions



### Series R, R100, M and 30 Miniature and Instrument Bearings; Series 1900, 100, 200 and 300 Metric Ultra Light, Extra Light, Light and Medium Turbine Bearings

**Separable Type (B):** Outer ring has full shoulders, inner ring has one shoulder cut away. The inner ring is removable for mounting on the shaft separately from the outer ring assembly.

**Non-separable Type (H):** Inner ring has full shoulders, outer has one shoulder cut away with a small retaining lip at the edge of raceway.

**Non-separable Type (J):** Outer ring has full shoulders, inner ring has one shoulder cut away with a small retaining lip at the edge of raceway.

**Materials:** The standard material for angular contact bearings is SAE 52100 bearing steel for both rings and balls. With the option of using silicon nitride ceramic balls even higher speeds can be attained. Other materials available are AISI 440C corrosion resistant steel, Cronidur 30 high nitrogen steel and M50 tool steel.

**Lubricant:** Angular contact bearings can be supplied with a range of lubricants. Lubricant type should be specified when ordering based on application requirements.

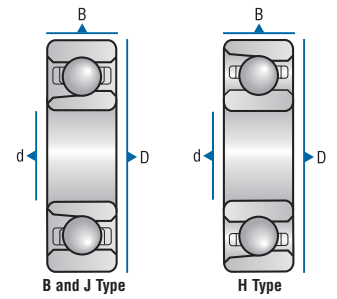
For applications that cannot tolerate extreme fits, selective fitting with calibrated parts should be considered. See Engineering section for details.








# ANGULAR CONTACT (INCH)

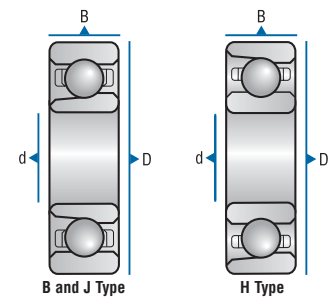
Bore Diameters: 2.380mm to 12.700mm



BASIC BEARING NUMBER	Static Capacity		Basic Dynamic Load Rating C (N)	BEARING NOMENCLATURE			ATTAINABLE SPEEDS (RPM)	
							Oil	Grease
				B Type: Separable	J Type: Non-separable	H Type: Non-separable		
R1-5B	53	89	254	R1-5B	—	—	267,000	214,000
R1-5H	62	89	285	—	—	R1-5H	267,000	214,000
R144H	31	89	169	—	—	R144H	315,000	268,000
R2-5B	67	125	280	R2-5B	—	—	244,000	195,000
R2-5H	67	93	285	—	—	R2-5H	244,000	195,000
R2B	67	107	289	R2B	—	—	202,000	162,000
R2H	111	133	400	—	—	R2H	202,000	162,000
R2-6H	71	133	356	—	—	R2-6H	202,000	162,000
R3B	151	240	605	R3B	—	—	152,000	122,000
R3H	151	231	676	—	—	R3H	152,000	122,000
R4B	191	307	689	R4B	—	—	116,000	93,000
R4H	218	289	756	—	—	R4H	116,000	93,000
R4HX8	916	1,810	2,313	—	—	R4HX8	130,000	100,000
R8H	2,073	1,308	3,981	—	—	R8H	57,000	47,000

# ANGULAR CONTACT (METRIC)

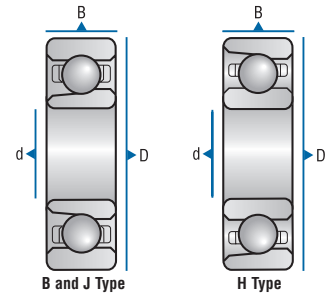
Bore Diameters: 3mm to 17mm






BASIC BEARING NUMBER	Bore Diameter d		Outside Diameter D		Width B		Maximum Shaft/Housing Radius Which Bearing Corner Will Clear r <sub>1</sub> Max.		Maximum Shaft/Housing Radius Which Bearing Corner Will Clear r <sub>2</sub> Max. Non-Thrust Side		Contact Angle	nd <sup>2</sup>
	mm	inch	mm	inch	mm	inch	mm	inch	mm	inch		
2M3BY3	3.000	0.1181	10.000	0.3937	4.000	0.1575	0.15	0.006	0.15	0.006	20°	0.0273
34H	4.000	0.1575	16.000	0.6299	5.000	0.1969	0.30	0.012	0.13	0.005	12°	0.1250
34BX4	4.000	0.1575	16.000	0.6299	5.000	0.1969	0.30	0.012	0.13	0.005	15°	0.9380
34-5	5.000	0.1969	16.000	0.6299	5.000	0.1969	0.30	0.012	0.13	0.005	14°	0.9380
19M5BY1	5.000	0.1969	13.000	0.5118	4.000	0.1575	0.15	0.006	0.15	0.006	25°	0.4300
36H	6.000	0.2362	19.000	0.7480	6.000	0.2362	0.30	0.012	0.13	0.005	15°	0.1582
36BX1	6.000	0.2362	19.000	0.7480	6.000	0.2362	0.30	0.012	0.13	0.005	11°	0.1187
37H	7.000	0.2756	22.000	0.8661	7.000	0.2756	0.30	0.012	0.13	0.005	14°	0.2197
38H	8.000	0.3150	22.000	0.8661	7.000	0.2756	0.30	0.012	0.25	0.010	14°	0.2197
38BX2	8.000	0.3150	22.000	0.8661	7.000	0.2756	0.30	0.012	0.13	0.005	15°	0.1709
39H	9.000	0.3543	26.000	1.0236	8.000	0.3150	0.30	0.012	0.25	0.010	15°	0.3164
100H	10.000	0.3937	26.000	1.0236	8.000	0.3150	0.30	0.012	0.25	0.010	15°	0.3164
200H	10.000	0.3937	30.000	1.1811	9.000	0.3543	0.64	0.025	0.38	0.015	15°	0.4307
1901H	12.000	0.4724	24.000	0.9449	6.000	0.2362	0.30	0.012	0.15	0.006	15°	0.2686
101H	12.000	0.4724	28.000	1.1024	8.000	0.3150	0.30	0.012	0.25	0.010	15°	0.3516
101BX48	12.000	0.4724	28.000	1.1024	8.000	0.3150	0.30	0.012	0.25	0.010	15°	0.3516
201H	12.000	0.4724	32.000	1.2598	10.000	0.3937	0.64	0.025	0.38	0.015	15°	0.3867
301H	12.000	0.4724	37.000	1.4567	12.000	0.4724	1.00	0.040	0.50	0.020	15°	0.6350
1902H	15.000	0.5906	28.000	1.1024	7.000	0.2756	0.30	0.012	0.15	0.006	15°	0.3418
102H	15.000	0.5906	32.000	1.2598	9.000	0.3543	0.30	0.012	0.25	0.010	15°	0.3867
102BX48	15.000	0.5906	32.000	1.2598	9.000	0.3543	0.30	0.012	0.25	0.010	15°	0.3867
102BJX6	15.000	0.5906	32.000	1.2598	9.000	0.3543	0.30	0.012	0.25	0.010	15°	0.3515
202H	15.000	0.5906	35.000	1.3780	11.000	0.4331	0.64	0.025	0.38	0.015	15°	0.6250
302H	15.000	0.5906	42.000	1.6535	13.000	0.5118	1.00	0.040	0.50	0.020	15°	1.0635
103H	17.000	0.6693	35.000	1.3780	10.000	0.3937	0.30	0.012	0.25	0.010	15°	0.4570
103BX48	17.000	0.6693	35.000	1.3780	10.000	0.3937	0.30	0.012	0.25	0.010	15°	0.4570
203H	17.000	0.6693	40.000	1.5748	12.000	0.4724	0.64	0.025	0.38	0.015	15°	0.7056
303H	17.000	0.6693	47.000	1.8504	14.000	0.5512	1.00	0.040	0.50	0.020	15°	1.1816

# ANGULAR CONTACT (METRIC)

Bore Diameters: 3mm to 17mm

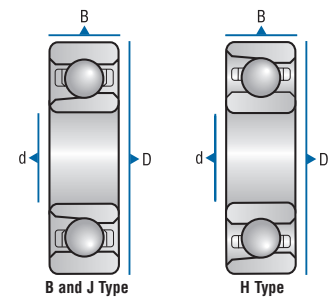


BASIC BEARING NUMBER	Static Capacity		Basic Dynamic Load Rating C (kN)	BEARING NOMENCLATURE			ATTAINABLE SPEEDS (RPM)	
	Radial C <sub>0</sub> (kN)	Thrust T <sub>0</sub> (kN)		 B Type: Separable	 J Type: Non-separable	 H Type: Non-separable	Oil	Grease
2M3BY3	0.07	0.11	0.29	2M3BY3	–	–	315,000	230,000
34H	0.48	0.52	1.45	–	–	34H	183,000	140,000
34BX4	0.15	0.18	0.72	34BX4	–	–	183,000	140,000
34-5	0.21	0.32	0.88	34-5B	–	34-5H	183,000	140,000
19M5BY1	0.12	0.25	0.47	19M5BY1	–	–	200,000	140,000
36H	0.64	0.77	1.86	–	–	36H(JB)	250,000	166,600
36BX1	0.20	0.24	0.93	36BX1	–	–	162,000	105,000
37H	0.92	1.35	2.48	–	–	37H(JB)	132,000	85,800
38H	0.92	1.35	2.48	–	–	38H(JH)	132,000	85,800
38BX2	0.43	0.62	1.53	38BX2	–	–	88,000	57,000
39H	1.33	2.60	3.44	–	–	39H(JB)	132,000	85,800
100H	2.37	2.70	5.33	–	–	100HJH	150,000	100,000
200H	4.06	3.23	6.97	–	–	200HJB	150,000	100,000
1901H	2.79	3.93	4.48	–	–	1901HJH	125,000	83,300
101H	2.77	3.12	5.82	–	–	101HJH	125,000	83,300
101BX48	2.32	3.46	4.58	101BX48	–	–	125,000	83,300
201H	3.78	5.13	5.95	–	–	201HJH	125,000	83,300
301H	5.62	8.85	9.91	–	–	301HJH	125,000	62,500
1902H	3.79	5.19	5.25	–	–	1902HJH	100,000	66,600
102H	4.13	4.30	6.24	–	–	102HJB	100,000	66,600
102BX48	2.70	3.91	4.96	102BX48	–	–	100,000	66,600
102BJJX6	2.76	5.25	5.88	–	102BJJX6	–	100,000	66,600
202H	6.09	4.85	9.67	–	–	202HJB	100,000	66,600
302H	9.47	14.50	15.30	–	–	302HJH	100,000	50,000
103H	3.94	3.87	6.97	–	–	103HJH	88,200	58,800
103BX48	3.30	5.78	5.56	103BX48	–	–	88,200	58,800
203H	7.09	10.47	10.91	–	–	203HJH	88,200	58,800
303H	11.15	16.60	16.91	–	–	303HJH	88,200	44,100

Tables continued on next page

# ANGULAR CONTACT (METRIC)

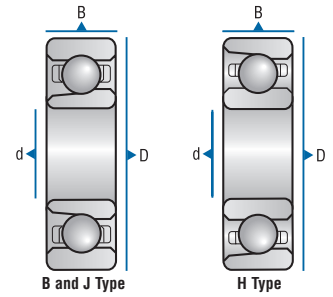
Bore Diameters: 20mm to 50mm






BASIC BEARING NUMBER	Bore Diameter d		Outside Diameter D		Width B		Maximum Shaft/Housing Radius Which Bearing Corner Will Clear r <sub>1</sub> Max.		Maximum Shaft/Housing Radius Which Bearing Corner Will Clear r <sub>2</sub> Max. Non-Thrust Side		Contact Angle	nd <sup>2</sup>
	mm	inch	mm	inch	mm	inch	mm	inch	mm	inch		
104H	20.000	0.7874	42.000	1.6535	12.000	0.4724	0.64	0.025	0.38	0.015	15°	0.6875
104BX48	20.000	0.7874	42.000	1.6535	12.000	0.4724	0.64	0.025	0.38	0.015	15°	0.6875
204H	20.000	0.7874	47.000	1.8504	14.000	0.5512	1.00	0.040	0.50	0.020	15°	0.9766
304H	20.000	0.7874	52.000	2.0472	15.000	0.5906	1.00	0.040	0.50	0.020	15°	1.4854
1905H	25.000	0.9843	42.000	1.6535	9.000	0.3543	0.30	0.012	0.25	0.010	15°	0.7656
105H	25.000	0.9843	47.000	1.8504	12.000	0.4724	0.64	0.025	0.38	0.015	15°	0.8125
105BX48	25.000	0.9843	47.000	1.8504	12.000	0.4724	0.64	0.025	0.38	0.015	15°	0.8125
205H	25.000	0.9843	52.000	2.0472	15.000	0.5906	1.00	0.040	0.50	0.020	15°	1.0742
305H	25.000	0.9843	62.000	2.4409	17.000	0.6693	1.00	0.040	0.50	0.020	15°	2.1973
106H	30.000	1.1811	55.000	2.1654	13.000	0.5118	1.00	0.040	0.50	0.020	15°	1.1074
106BX48	30.000	1.1811	55.000	2.1654	13.000	0.5118	1.00	0.040	0.50	0.020	15°	1.1074
206H	30.000	1.1811	62.000	2.4409	16.000	0.6299	1.00	0.040	0.50	0.020	15°	1.8154
306H	30.000	1.1811	72.000	2.8346	19.000	0.7480	1.00	0.040	1.00	0.040	15°	2.8223
1907H	35.000	1.3780	55.000	2.1654	10.000	0.3937	0.64	0.025	0.38	0.015	15°	1.1875
107H	35.000	1.3780	62.000	2.4409	14.000	0.5512	1.00	0.040	0.50	0.020	15°	1.4648
107BX48	35.000	1.3780	62.000	2.4409	14.000	0.5512	1.00	0.040	0.50	0.020	15°	1.4648
207H	35.000	1.3780	72.000	2.8346	17.000	0.6693	1.00	0.040	0.50	0.020	15°	2.2969
307H	35.000	1.3780	80.000	3.1496	21.000	0.8268	1.50	0.060	0.76	0.030	15°	3.4805
108H	40.000	1.5748	68.000	2.6772	15.000	0.5906	1.00	0.040	0.50	0.020	15°	1.6602
108BX48	40.000	1.5748	68.000	2.6772	15.000	0.5906	1.00	0.040	0.50	0.020	15°	1.6602
208H	40.000	1.5748	80.000	3.1496	18.000	0.7087	1.00	0.040	0.50	0.020	15°	2.6367
308H	40.000	1.5748	90.000	3.5433	23.000	0.9055	1.50	0.060	0.76	0.030	15°	1.0742
109H	45.000	1.7717	75.000	2.9528	16.000	0.6299	1.00	0.040	0.50	0.020	15°	2.2500
209H	45.000	1.7717	85.000	3.3465	19.000	0.7480	1.00	0.040	0.50	0.020	15°	2.8564
309H	45.000	1.7717	100.000	3.9370	25.000	0.9843	1.50	0.060	0.76	0.030	15°	5.1992
110H	50.000	1.9685	80.000	3.1496	16.000	0.6299	1.00	0.040	0.50	0.020	15°	2.5313
110BX48	50.000	1.9685	80.000	3.1496	16.000	0.6299	1.00	0.040	0.50	0.020	15°	2.5313
210H	50.000	1.9685	90.000	3.5433	20.000	0.7874	1.00	0.040	0.50	0.020	15°	3.5000

# ANGULAR CONTACT (METRIC)

Bore Diameters: 20mm to 50mm

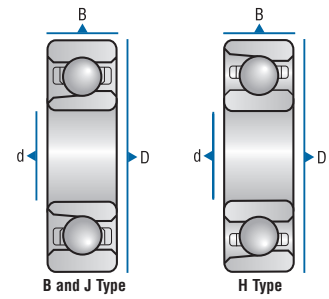


BASIC BEARING NUMBER	Static Capacity		Basic Dynamic Load Rating C (kN)	BEARING NOMENCLATURE			ATTAINABLE SPEEDS (RPM)	
	Radial C <sub>0</sub> (kN)	Thrust T <sub>0</sub> (kN)		 B Type: Separable	 J Type: Non-separable	 H Type: Nonseparable	Oil	Grease
104H	5.72	6.29	10.49	–	–	104HJH	75,000	50,000
104BX48	4.79	8.79	8.32	104BX48	–	–	75,000	50,000
204H	9.85	9.06	14.60	–	204JJJ	204HJH	75,000	50,000
304H	13.65	20.52	21.02	–	–	304HJB	75,000	37,500
1905H	8.69	11.85	10.48	–	–	1905HJH	60,000	40,000
105H	9.05	8.75	11.70	–	–	105HJH	60,000	40,000
105BX48	5.92	12.46	9.30	105BX48	–	–	60,000	40,000
205H	11.43	10.22	15.67	–	–	205HJB	60,000	40,000
305H	18.55	29.98	29.51	–	–	305HJB	60,000	30,000
106H	14.99	9.86	15.09	–	–	106HJH	50,000	33,300
106BX48	8.20	13.80	12.08	106BX48	–	–	50,000	33,300
206H	18.76	26.61	25.06	–	–	206HJH	50,000	33,300
306H	27.07	39.88	37.27	–	–	306HJH	50,000	25,000
1907H	14.04	18.80	14.67	–	–	1907HJH	42,800	28,500
107H	16.68	22.63	19.13	–	–	107HJB	42,800	28,500
107BX48	10.90	18.21	15.26	107BX48	–	–	42,800	28,500
207H	24.42	24.66	30.46	–	–	207HJH	42,800	28,500
307H	34.42	50.13	44.52	–	–	307HJH	42,800	21,400
108H	19.39	18.78	20.52	–	–	108HJH	37,500	25,000
108BX48	12.67	26.90	16.39	100BX48	–	–	37,500	25,000
208H	28.40	40.07	34.47	–	–	208HJH	37,500	25,000
308H	43.05	62.19	54.05	–	–	308HJH	37,500	18,800
109H	25.82	34.88	27.62	–	–	109HJH	33,300	22,200
209H	31.52	31.46	36.27	–	–	209HJB	33,300	22,200
309H	52.10	75.35	64.12	–	–	309HJH	33,300	16,700
110H	29.59	39.66	29.61	–	–	110HJH	30,000	20,000
110BX48	19.33	41.04	23.69	110BX48	–	–	30,000	20,000
210H	38.71	38.75	41.19	–	–	210HJH	30,000	20,000

Tables continued on next page

# ANGULAR CONTACT (METRIC)

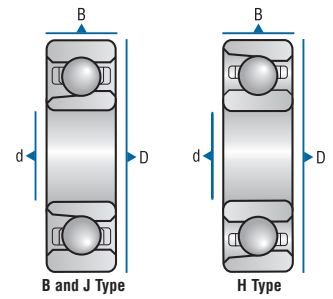
Bore Diameters: 50mm to 100mm






BASIC BEARING NUMBER	Bore Diameter d		Outside Diameter D		Width B		Maximum Shaft/Housing Radius Which Bearing Corner Will Clear r <sub>1</sub> Max.		Maximum Shaft/Housing Radius Which Bearing Corner Will Clear r <sub>2</sub> Max. Non-Thrust Side		Contact Angle	nd <sup>2</sup>
	mm	inch	mm	inch	mm	inch	mm	inch	mm	inch		
310H	50.000	1.9685	110.000	4.3307	27.000	1.0630	2.00	0.080	1.00	0.040	15°	6.1875
211H	55.000	2.1654	100.000	3.9370	21.000	0.8268	1.50	0.060	0.76	0.030	15°	4.4297
212H	60.000	2.3622	110.000	4.3307	22.000	0.8661	1.50	0.060	0.76	0.030	15°	5.4688
312H	60.000	2.3622	130.000	5.1181	31.000	1.2205	2.00	0.080	1.00	0.040	15°	10.5000
113H	65.000	2.5591	100.000	3.9370	18.000	0.7087	1.00	0.040	0.50	0.020	15°	3.6367
113BX48	65.000	2.5591	100.000	3.9370	18.000	0.7087	1.00	0.040	0.50	0.020	15°	3.4453
214H	70.000	2.7559	125.000	4.9213	24.000	0.9449	1.50	0.060	0.76	0.030	15°	7.0898
115H	75.000	2.9528	115.000	4.5276	20.000	0.7874	1.00	0.040	0.50	0.020	15°	5.0000
117H	85.000	3.3465	130.000	5.1181	22.000	0.8661	1.00	0.040	0.50	0.020	15°	6.6445
117BX48	85.000	3.3465	130.000	5.1181	22.000	0.8661	1.00	0.040	0.50	0.020	15°	6.3281
118H	90.000	3.5433	140.000	5.5118	24.000	0.9449	1.50	0.060	0.76	0.030	15°	7.4219
220H	100.000	3.9370	180.000	7.0866	34.000	1.3386	2.00	0.080	1.00	0.040	15°	15.0000

## ANGULAR CONTACT (METRIC)

Bore Diameters: 50mm to 100mm



BASIC BEARING NUMBER	Static Capacity		Basic Dynamic Load Rating C (kN)	BEARING NOMENCLATURE			ATTAINABLE SPEEDS (RPM)	
	Radial $C_0$ (kN)	Thrust $T_0$ (kN)					Oil	Grease
				B Type: Separable	J Type: Non-separable	H Type: Non-separable		
310H	62.31	89.55	75.11	-	-	310HJH	30,000	20,000
211H	48.71	67.25	52.96	-	-	211HJH	27,200	18,000
212H	60.04	60.34	64.05	-	-	212HJH	25,000	16,600
312H	87.77	132.05	105.28	-	-	312HJH	25,000	12,500
113H	43.32	47.35	40.05	-	-	113HJH	23,000	15,300
113BX48	26.79	57.05	30.96	113BX48	-	-	23,000	15,300
214H	78.73	108.09	79.38	-	-	214HJH	21,400	14,200
115H	59.65	79.41	52.66	-	-	115HJH	20,000	13,300
117H	79.33	105.14	67.20	-	-	117HJH	17,600	11,700
117BX48	49.35	105.16	52.09	117BX48	-	-	17,600	11,700
118H	87.95	117.80	76.40	-	-	118HJH	16,600	11,100
220H	166.01	229.28	155.92	-	-	220HJH	15,000	10,000





# SPECIAL APPLICATIONS



# SPECIAL APPLICATIONS

## Introduction

Barden innovations in special bearings range from nearly standard bearings with slightly modified dimensions, to intricate assemblies which integrate the bearing function into a complete mechanism. Our engineers work closely with customers to develop unique bearing designs with specialised features to meet application requirements and solve functional problems.

In many cases the overall cost of a piece of equipment can be reduced by incorporating special or customised bearings particularly when mating components are integrated into the bearing such as mounting flanges, gear teeth, spring carriers and integral O-ring grooves. The performance and installation benefits to be gained from using bearings specifically designed for individual applications are as follows:

- Improved assembly reliability
- Enhanced rigidity or stability of the system
- Better location control through proper bearing orientation
- Reduction in handling operations and contamination
- Improved alignment of the rotating assembly
- Weight reduction
- Improved resistance to temperature extremes
- Reduction in tolerance stack-up

# SPECIAL APPLICATIONS

## Table of Contents

The following section is divided into some of the major market sectors where the use of special bearings is well established.

Market Sector	Page Number
High Speed Dental Handpiece Bearings .....	52
Vacuum Pumps and Magnetic Spindle	
Touchdown Bearings .....	54
Auto Sport and Formula 1 Racing .....	56
Gyro Bearings .....	58
Aerospace Accessory Bearings .....	60
X-Ray .....	62
Canning Industry .....	64

## SPECIAL APPLICATIONS

### High Speed Dental Handpiece Bearings



*The severe demands of mixed friction conditions found in dental handpieces make Barden bearings the ideal choice.*

For over 25 years the Barden Corporation has been developing and producing precision bearings for the ultra high speed dental handpiece application for both the OEM and replacement markets.

Arguably one of the most arduous applications for precision bearings, handpiece turbines operate at speeds up to 500,000 rpm and are subjected to repeated sterilisation cycles.

All Barden dental bearings have super honed finished raceways with strict controls of roundness, harmonic amplitudes and lobing patterns. All assembly, test and packing operations are carried out in clean room conditions.

Barden dental bearings are available in both deep groove and angular contact configurations. They can be supplied with or without shields for lubricant retention and contamination exclusion and some types are available with flanged or stepped outer ring OD's for O-ring location. A range of cage materials are available for sterilisation resistance including Torlon and Phenolic.

For certain markets all types can be supplied with Silicon Nitride ceramic balls with the advantage of lower centrifugal ball loads at the high rotational speed of the turbine. These lower loads produce less stress between the balls and the cage with the result that the cages will generally withstand a greater number of sterilisation cycles than bearings with steel balls. As a result, operational life and reliability are increased.

All Barden dental bearings are supplied ready to use with a controlled quantity of grease lubrication that was specially developed for this application.

As with all Barden products full technical support is provided for this product line from a team of specialist engineers with a laboratory having run test fixtures with vibration and speed monitoring, sterilisation equipment and full resources to complete bearing examinations of all types.

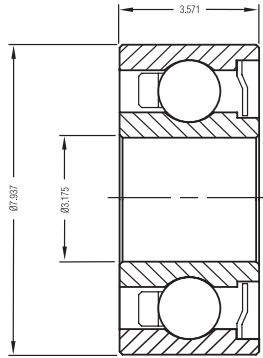


*All Barden precision bearings are assembled under stringent clean room conditions.*

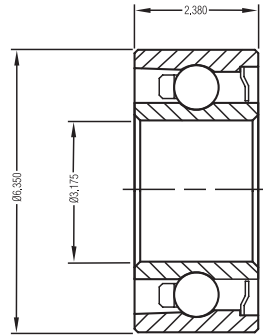
A selection of the basic types available are shown on the following page.

# SPECIAL APPLICATIONS

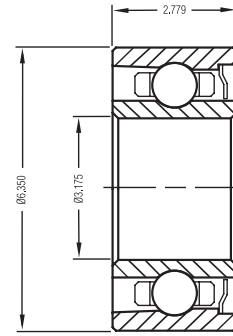
## High Speed Dental Handpiece Bearings



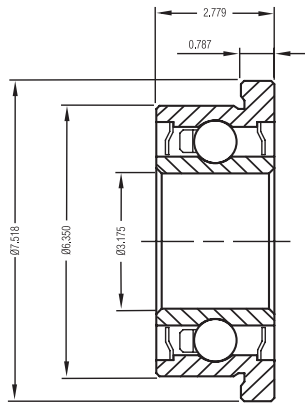
SR2-5STAY36



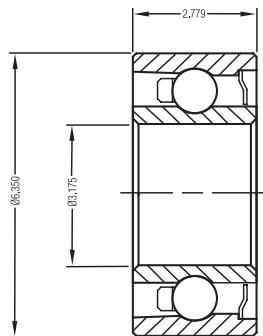
SR144STAY134



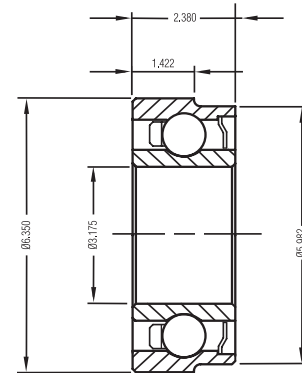
SR144HSX27



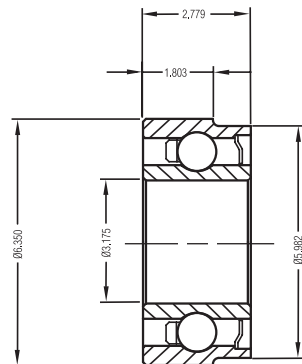
SFR144SSTAY186



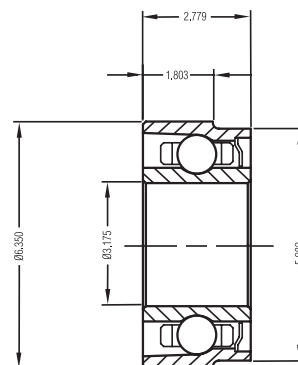
SR144STAY64



SR144STAY39



SR144STAY85

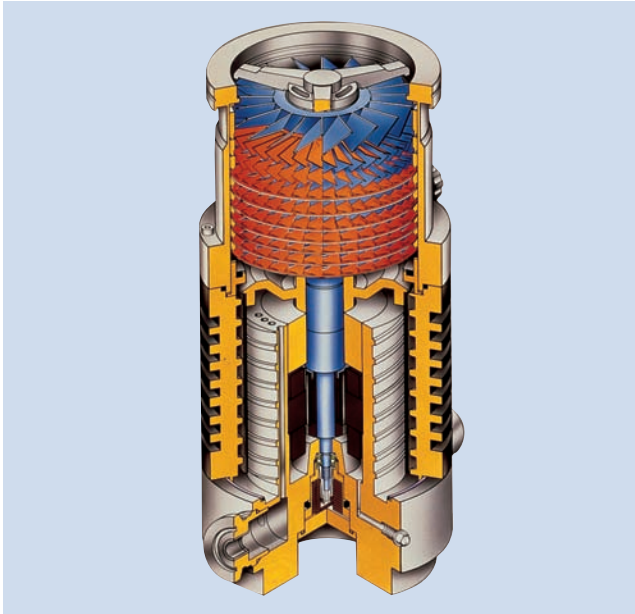


SR144HSY161

All dimensions in millimeters.

## SPECIAL APPLICATIONS

### Vacuum Pumps and Magnetic Spindle “Touchdown” Bearings



*Vacuum pump bearings must endure a range of hostile operating conditions, an environment ideally suited for Barden precision bearings.*

Barden has established an expertise in developing bearings for the whole of the pump market sector. Using new materials and by adding value, bearings can be designed to meet the harsh requirements of today's high performance pump market.

Some of the factors that make high precision bearings the first choice are high temperatures, high speeds, low vibration levels, abnormal contamination levels, poor lubrication, high reliability and long life.

Among the areas of expertise in which Barden bearings are already proven as the solution provider are turbo molecular pump bearings, dry pump bearings and emergency touch down bearings for magnetically supported pumps.

#### **Turbomolecular Pumps**

The most important requirements for a bearing used in this application are long life, reliability and high-speed performance. To this end the use of X-life Ultra bearings, ceramic balls, greased for life and special high quality raceway finishes has become the Barden standard. Current “greased-for-life” bearing technology can consistently give 30,000+ hour life at 500,000+ dN.

#### **Dry Pump Bearings**

Whilst the speed requirements on the bearings for this type of application are often lower than usual, other factors including temperature, contamination and reliability mean that a special bearing design is necessary in order to meet the application requirements. Barden is able to design dry pump bearings for optimal performance with both oil and grease lubrication. Also, by adding value to the bearing so that it reduces assembly cost and pump component count, additional performance and economic benefits can be gained from the use of Barden's special bearings.

#### **Emergency Touchdown/Auxiliary Bearings**

This special application area requires bearings that can withstand the harshest conditions. To successfully control a shaft on which the magnetic bearings have failed often requires a bearing that can accelerate from zero to 2 million or higher dN virtually instantaneously. In addition the bearing system must then control the rotor under the very high radial, axial and shock loading. Barden has developed bearings for this application using a full of ceramic ball design with Cronidur 30 material to give exceptional performance and corrosion resistance. Barden is able to optimise the bearing design for the maximum number of touchdowns.

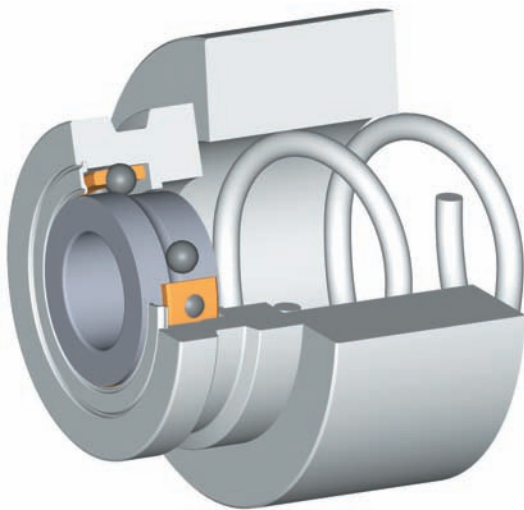
#### **Special design features**

Here are some of the added value design features that enable Barden's special bearings to work reliably in high-performance pumping applications:

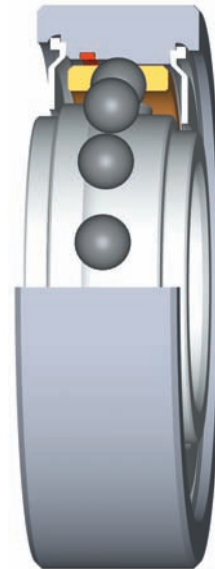
- Cronidur 30 High-Nitrogen Steel – for optimum performance and reliability
- High-performance Ceramic Balls – chosen to meet the performance and corrosion-resistance requirements
- High-speed Small Ball Technology – for improved pumping speeds
- Shielded Angular Contact Design – to guard against contamination ingress and prolong lubricant life
- Special Internal Design – to maximise the in-application performance
- Special Barden “TMP Standard” Internal Finish – for quieter running, longer life and high reliability

## SPECIAL APPLICATIONS

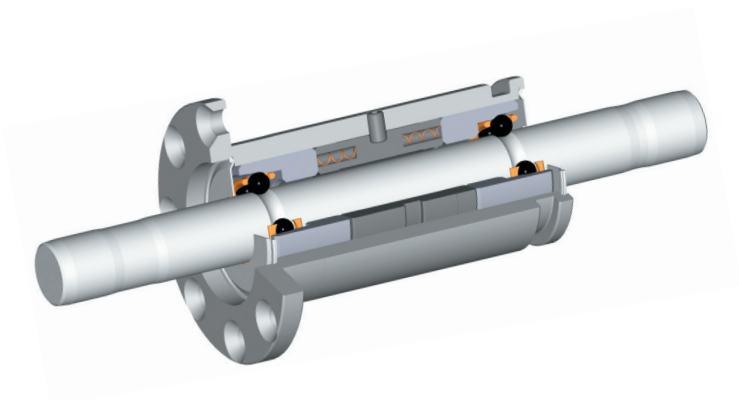
### Vacuum Pumps and Magnetic Spindle “Touchdown” Bearings



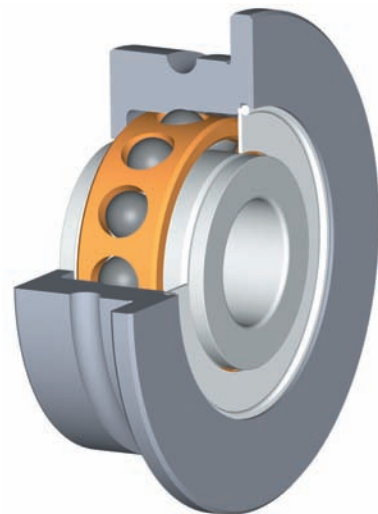
TMP Integrated Spring Carrier  
and Damping Ring Groove



Dry Pump Bearing  
with Grease  
Reservoir



TMP Integrated shaft assembly



TMP Flange Bearing with  
Integral Damping Ring Groove

## SPECIAL APPLICATIONS

### Auto Sport and Formula 1 Racing



*Barden precision bearings are used in a wide range of racing applications where reliable performance is critical.*

#### Formula 1 Precision Bearings

Through its Formula 1 Precision range, Barden has engineered a series of extreme high-performance bearing systems for race-critical applications such as clutch release, gearbox, wheel and suspension.

Elements of Barden's Formula 1 Precision range are used by the major race teams, and new designs are created and race-proven every season. The quest, as ever, is to extract maximum performance from the smallest design envelope with the highest reliability factor.

#### Clutch Release

The pedigree of Barden's clutch release bearing systems is well established, with full race-qualification at a number of major race teams. The trend is to develop smaller, more efficient clutch systems, offering optimum performance with reduced mass. In response, Barden has introduced a range of new advanced clutch release bearing designs incorporating special features such as integral metal shields, labyrinth-style architectures and high-temperature bespoke lubricants.

#### Gearbox

Barden's gearbox bearings are "tailored" to interface directly with the transmission designs of individual race teams. Incorporating bespoke features such as flanges, splines and thread forms as integral parts of the bearing, together with direct oil feed systems all help to keep mass to a minimum

and ensure the optimum continuity of lubricant supply throughout the race.

#### Suspension

Barden offers a range of drop link suspension unit bearings and bearing systems for control and steering operations. These specialised bearings utilise super-precision rolling elements which offer low-friction and high-reliability.

#### Wheel

Barden's Formula 1 Precision wheel bearings are designed to accommodate the excessive radial, axial and moment loading experienced during high-speed cornering and hard acceleration or braking conditions. Available as duplex paired angular contact bearings, and utilising state of the art "race-age" technologies, the bearings have been designed to meet the demands of the toughest race circuits.

#### The X-life Ultra advantage

Barden's X-life Ultra bearings bring together the elements of advanced high-nitrogen Cronidur 30 steel, high-performance engineering ceramics, superior raceway finish and proven application experience into a world-leading design philosophy. For Formula 1 applications, this not only means improved operation in marginal lubrication conditions, but the option to "down-size" components due to the increased material load capacity.

As new design innovations are race-qualified by Formula 1, then existing proven designs are transferred over to other auto sport areas.

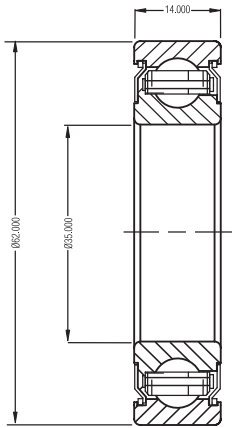
#### Performance vehicles

Increasing demand for compact, high-efficiency performance automobiles has brought forced-induction passenger vehicles to a position of prominence. Barden-powered ball bearing turbo- and super-chargers extract maximum power and driveability with design synergies that virtually eliminate turbo lag and compressor whine. Reduced compressor clearance, lower rotating inertia and maximum speed-ability can be achieved with the super accuracy of Barden bearings. In this way, drivers of performance vehicles are also able to benefit from the flow-down of Barden's Formula 1 Precision advanced bearing technologies.

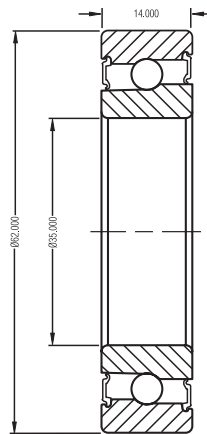


# Formula 1 Bearings

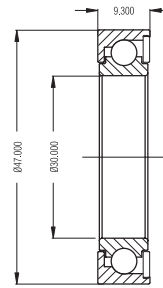
## CLUTCH RELEASE BEARINGS



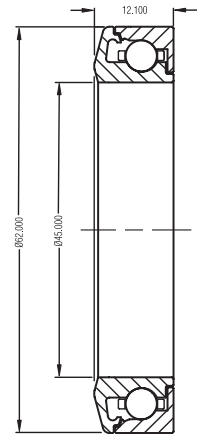
C107FFTY5



803455

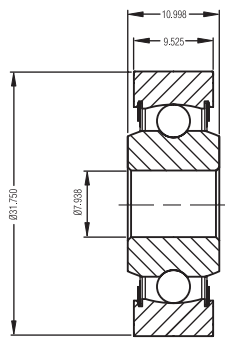


SCB1136Y2

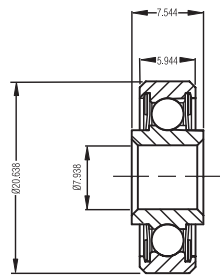


SCB1160

## SUSPENSION BEARINGS

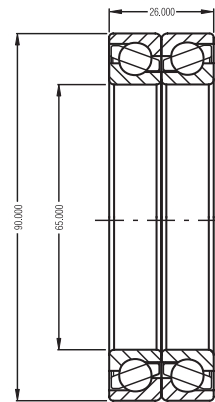


SCB982Y3



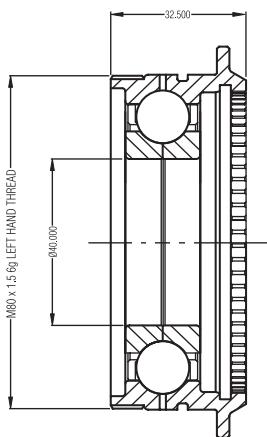
SCB1035Y2

## WHEEL BEARINGS



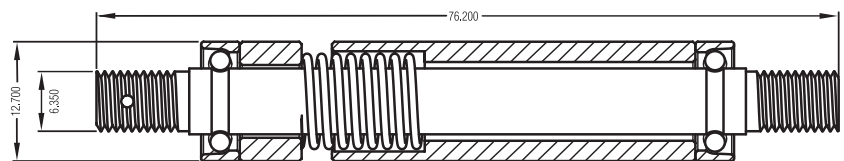
SCB1053

## GEARBOX BEARINGS



SCB1026

## TURBO CHARGER BEARING

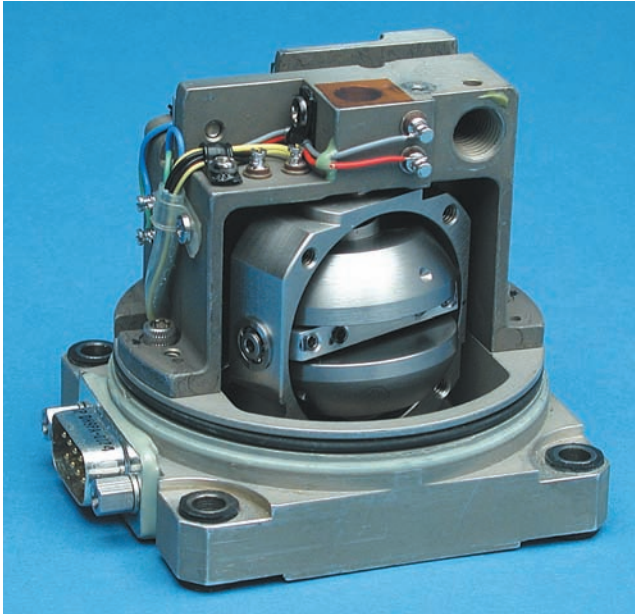


CZ1349

All dimensions in millimeters.

## SPECIAL APPLICATIONS

### Gyro Bearings



*The unique demands placed on gyros makes Barden precision bearings the only option.*

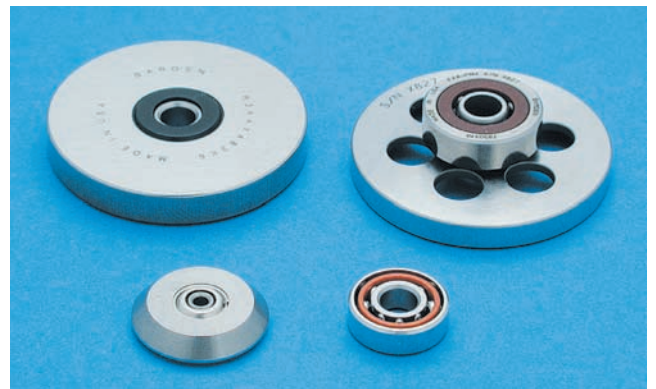
For over 45 years the Barden Corporation has been offering precision gyro bearing users an extremely wide range of special design bearings, and assemblies. Increased performance requirements of gyros in terms of drift rate, life and size have created a demand for bearings produced to carefully controlled tolerances of less than half a micrometer. This accuracy, plus close control of contact surface geometry and finish; cleanliness and ball retainer oil impregnation results in a number of benefits:

- Decreased vibration levels
- Longer useful life with fewer lubrication failures
- Greater stability of preload
- Reduced mass shift due to wear
- Greater performance uniformity from unit to unit

These improvements are accomplished by means of unusually close control of raw materials, metallurgy, geometry, runout errors, and all critical dimensions.

Barden can offer many bearing types ranging from conventional bearings with modified dimensions to intricate configurations designed to meet unusual performance or application problems. Many special assemblies include shaft or housing members designed integrally with bearing inner or outer rings to reduce mating

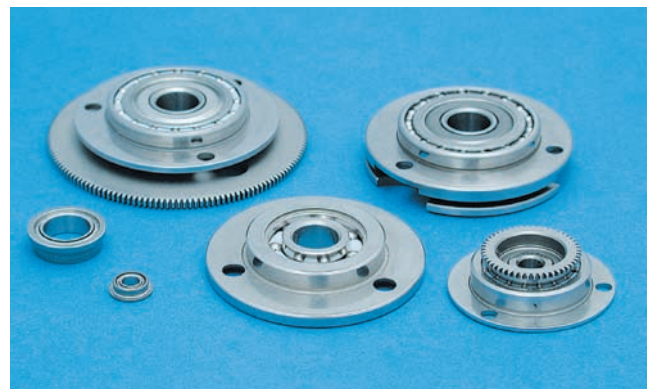
part errors and tolerance build-up, or to simplify component design and assembly. Such integrated designs have enabled gyro manufacturers to greatly improve the performance of their units, often with an overall reduction in production costs.



*Rotor bearings are made to precision tolerances for optimum performance.*

### Gyro Unit

Shown on the opposite page are some of the more common types of special design Barden gyro bearings. They include special bearings now so widely used that they have become virtually standard items. Only basic boundary dimensions are shown. Complete dimensions, specifications, and performance data will be furnished on request of the Barden engineering department.

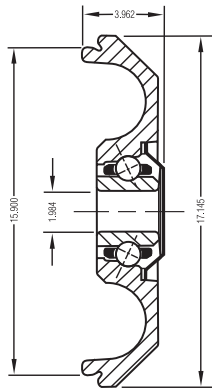


*Gimbal bearings are offered in a wide range of design configurations to fit a variety of special needs.*

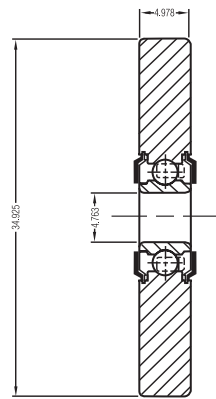
# SPECIAL APPLICATIONS

## Gyro Bearings

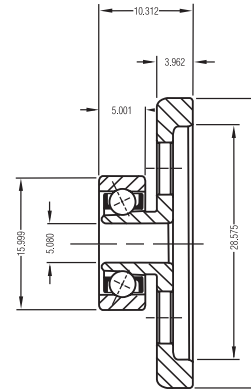
### END-BELL BEARINGS



Z155

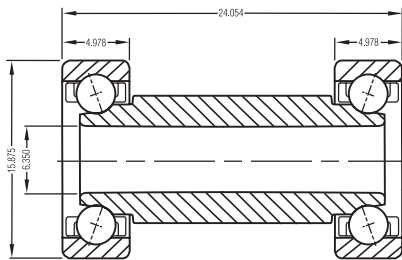


R3AAX483



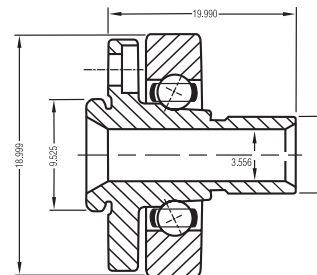
Z850X6

### SHAFT AND OUTER RING ASSEMBLIES



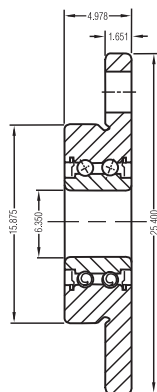
Z43

### FLANGED PIVOT AND OUTER RING ASSEMBLIES



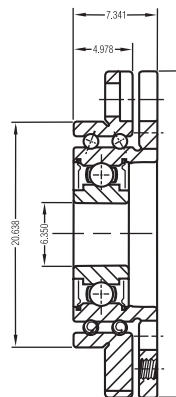
Z65

### DOUBLE ROW BEARINGS



Z96

### FRICION-CANCELING BEARINGS



Z224ZAX22

All dimensions in millimeters.

## SPECIAL APPLICATIONS

### Aerospace Accessory Bearings



*Specialty bearings include the flanged split inner ring configuration, shown here, used in precision aerospace applications.*

Custom designed and manufactured aerospace bearings are a cornerstone of the Barden product line. Aerospace bearings are specifically designed according to application requirements, and the engineering staff is often involved early in the development stages of aerospace equipment.

Barden bearings are utilised in pneumatic and electric starters and generators, gearboxes, main engines, and a variety of auxiliary aircraft positions. Bearing configurations range from standard deep groove bearings to intricate split inner ring designs. Thanks to a well equipped and versatile factory with experienced and flexible staff, The Barden Corporation is able to manufacture bearings with unusual materials and designs.

Unlike the product designs which vary, the product precision remains constant. Super precision ABEC 7 bearings are standard, and as a result, Barden aerospace bearings are capable of high speed, reliable operation, running quietly with minimum power losses.

Due to their unique design, split inner configurations can accept reversing thrust and combination loads. The bearings are assembled with one-piece high strength cages that are often silver plated for improved operation

under marginal lubrication conditions. Bearing configurations can include puller grooves, bore clips, and flanges, as required. Typically split inner ring bearings are manufactured from high temperature, high strength bearing steels such as M50 and Cronidur 30. Like in other applications, ceramic balls are available and can provide for higher speed operation.

Other typical aerospace configurations include the sealed deep groove bearing shown opposite. Deep groove bearings are greased and sealed for life at the factory in clean assembly rooms, and a variety of grease lubricants are available depending on the application requirements. Barden “T” cages are often recommended for these bearings. In addition to being light weight and strong, “T” cages generally improve lubricant life and allow for high speed bearing operation. The standard high temperature seal material is Viton. This material is generally not reactive with typical chemicals present in aerospace applications. Barden Flexeals are also available when higher operating speeds are required. Cronidur 30 rings and ceramic balls are often recommended to provide corrosion protection for bearings operating in harsh environments.

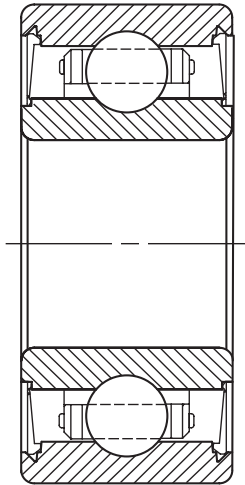
#### **Full complement bearings**

Full complement bearings capitalise on the space usually occupied by the ball retainer. This allows more balls with the consequential increase in load capacity, either predominantly radial, in the case of filling notch designs, or unidirectional axial and radial in the case of angular contact designs.

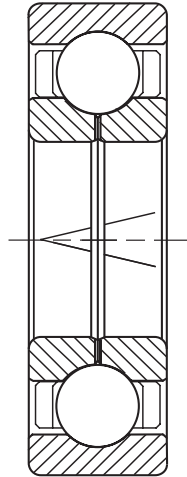
Applications vary from high temperature valves to missile fin support. Some designs meet Mil Specs AS27640, AS27641, and AS27642. Others are tailored to meet individual customer requirements.

# SPECIAL APPLICATIONS

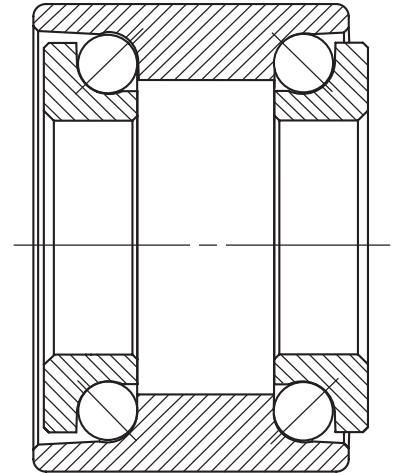
## Aerospace Accessory Bearings



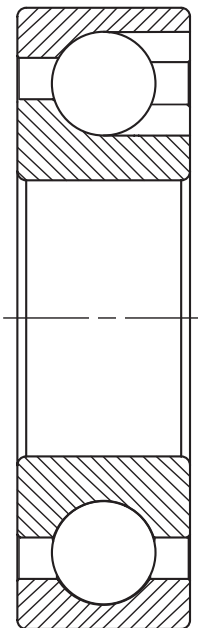
Sealed Deep Groove  
Generator Bearing



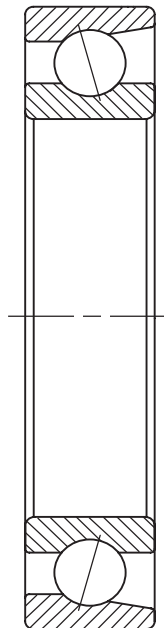
Gear Box Bearing  
With Split Inner Ring



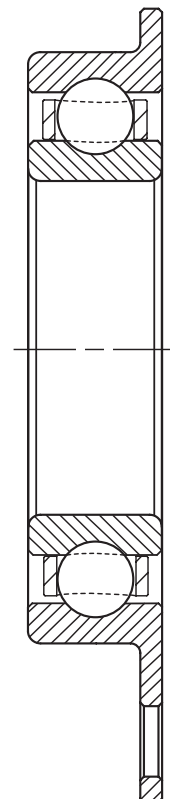
Double-Row  
Accessory Bearing



Deep Groove  
Full Complement  
Filling Notch Bearing



Angular Contact  
Full Complement  
Bearing



Flanged Deep Groove  
Gear Box Bearing

## SPECIAL APPLICATIONS

### X-Ray



*Barden super precision x-ray bearings enable medical scanner applications to provide images of the highest resolution.*

Barden continues to keep pace with advances in X-ray and CT technology with new, improved X-ray tube bearing designs. These bearings, which are used to support the spinning X-ray anode, operate at speeds in excess of 10,000 rpm under harsh conditions. In addition to withstanding the passage of high voltage, the bearing must also operate in a vacuum environment down to  $10^{-8}$  torr and at temperatures of 400–500°C.

Barden X-ray cartridge bearings are full ball complement designs, incorporating a flanged shaft with integral races to which the target anode is attached. A separate flange made of lower thermal conductivity material can be welded to the shaft in order to reduce heat transfer from the anode. The bearings are built with controlled axial clearance in order to compensate for thermal growth at the operating temperature. Conventional outer rings are separated by spacers with either solid or spring preloading that is designed to meet specific application requirements.

In order to provide effective lubrication under these extreme conditions Barden utilises advanced surface engineering technologies such as plasma and ion-beam assisted deposition. Working closely with specialist organisations in these fields, Barden is developing a range of advanced solid lubricants some 2000 times thinner than the human hair to compliment its high-temperature X-ray bearing materials.

With its dedicated “in-house” X-ray Bearing Test Facility, Barden is able to evaluate and verify the performance of its X-ray tube bearing designs and developments under simulated thermal-vacuum test conditions.

With the emphasis on improved patient care resulting from faster data acquisition and high-resolution imagery, Barden precision bearings provide a clear choice for advanced X-ray and medical scanner applications.

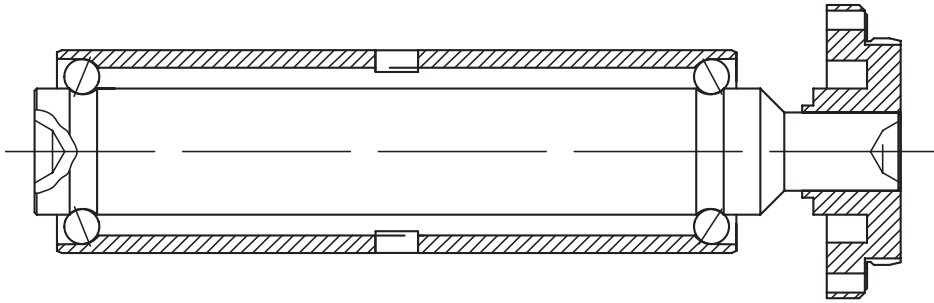


*Designed to operate under high vacuum at elevated temperatures, Barden bearings are an integral part of high-speed x-ray tubes.*

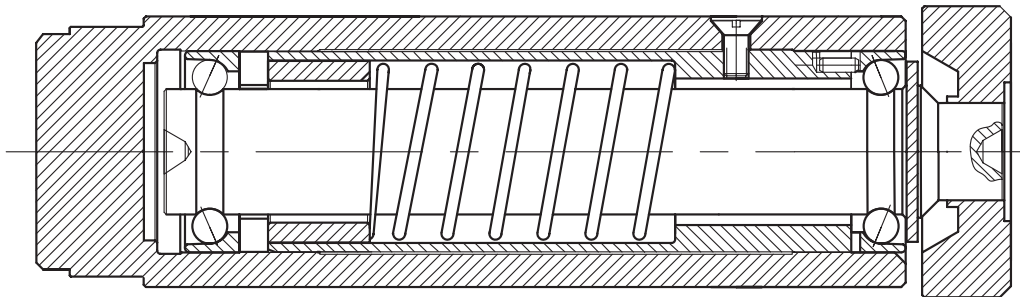
## SPECIAL APPLICATIONS

Examples of various x-ray bearing cartridge design configurations

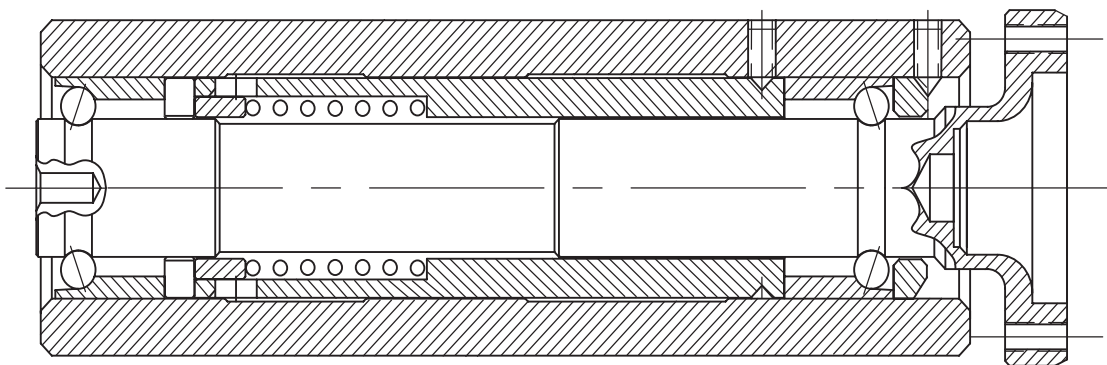
CARTRIDGE DESIGN



SPRING PRELOADED CARTRIDGE DESIGN WITH ENCLOSED HOUSING



SPRING PRELOADED CARTRIDGE DESIGN WITH OPEN HOUSING



## SPECIAL APPLICATIONS

### Canning Industry



*Barden's specialised bearings set the standard for performance and reliability in the high volume throughput canning industry.*

A can of food is something most people take for granted, yet it must count as one of the most revolutionary inventions of the last two hundred years. After all, here was a way to preserve fresh or cooked food for years at a time, while maintaining its nutritious qualities, and without requiring chemical additives or processes such as smoking, pickling, or salting.

The history of canned food began in 1810, when a Frenchman, Nicolas Appert, found that by heating food in a sealed airtight container, it would keep for very long periods of time; we now know that this is because the heating process kills the bacteria that cause food to spoil.

The very earliest cans were “tinned iron canisters,” which were very heavy and needed a hammer and chisel to open them! They were also made one at a time, by hand. Nowadays, can making and canning have changed beyond all recognition, and are high-speed, high-technology industries. Cans are manufactured at speeds of up to 1250 per minute, and printed and filled at similar speeds!

#### **How are cans made?**

Today, there are two basic ways of making cans. The common method for food cans is to use three separate pieces of tin plate, hence it is referred to as a “three piece can.” One rectangular piece is rolled over into a cylindrical

shape, so that the two edges just overlap. The edges are then welded together at high speed by a special process, to form the cylindrical body of the can. The top and bottom ends of the can are made separately, and the base is next seamed onto one end to form an airtight seal. The empty cans plus lids are transported to the food canner, who then fills the can, fixes the lid on, and carries out the “cooking” process.

The second way to make cans is to use a “two-piece” method, where the body and base is formed from a single sheet of material, and the lid is the second piece subsequently seamed on as before.

#### **What are cans made from?**

The base material for modern cans is either tin plated mild steel or aluminum.

#### **How are cans sealed?**

The cans body and lid are sealed by a metal forming process known as seaming. This process is the reforming of the parts into a new shape under pressure.

#### **What is the link with bearings?**

As the can body is round, the phases of can forming, shaping and seaming, etc. all rely on rolling element bearings for continued accuracy and speed of process.

Barden Precision angular contact ball bearings can be found in machinery that services the high and low volume canning industries.

#### **Bearing Characteristics**

The canning industry represents a particularly hostile environment for the bearings. In addition to aggressive media and harsh cleaning processes, bearing lubricants must also comply with environmental (FDA) guidelines that require the use of thin organic-based oils conferring only boundary lubrication characteristics for the majority of the operation. By combining the material properties of advanced corrosion-resistant steels with those of ceramic balls, Barden bearings demonstrate enhanced performance and reliability in the demanding environment of today's high-speed canning industry.



**SPECIAL APPLICATIONS**

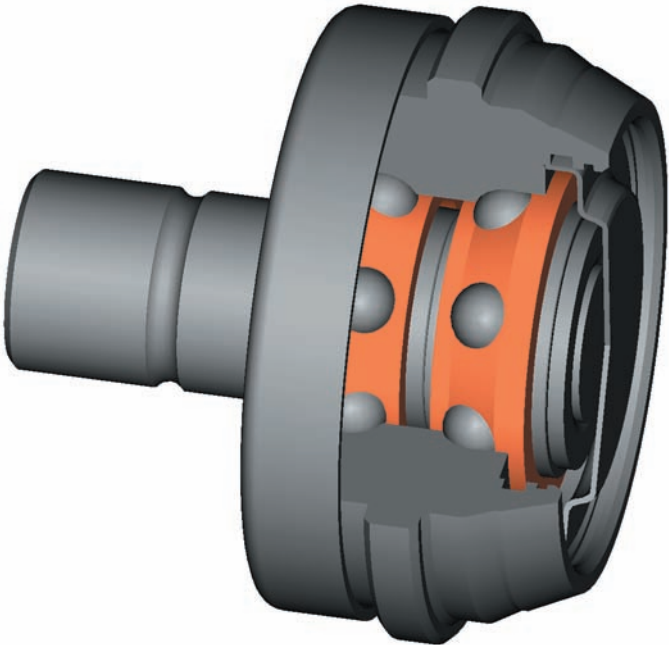
**Canning Industry**



SCB850



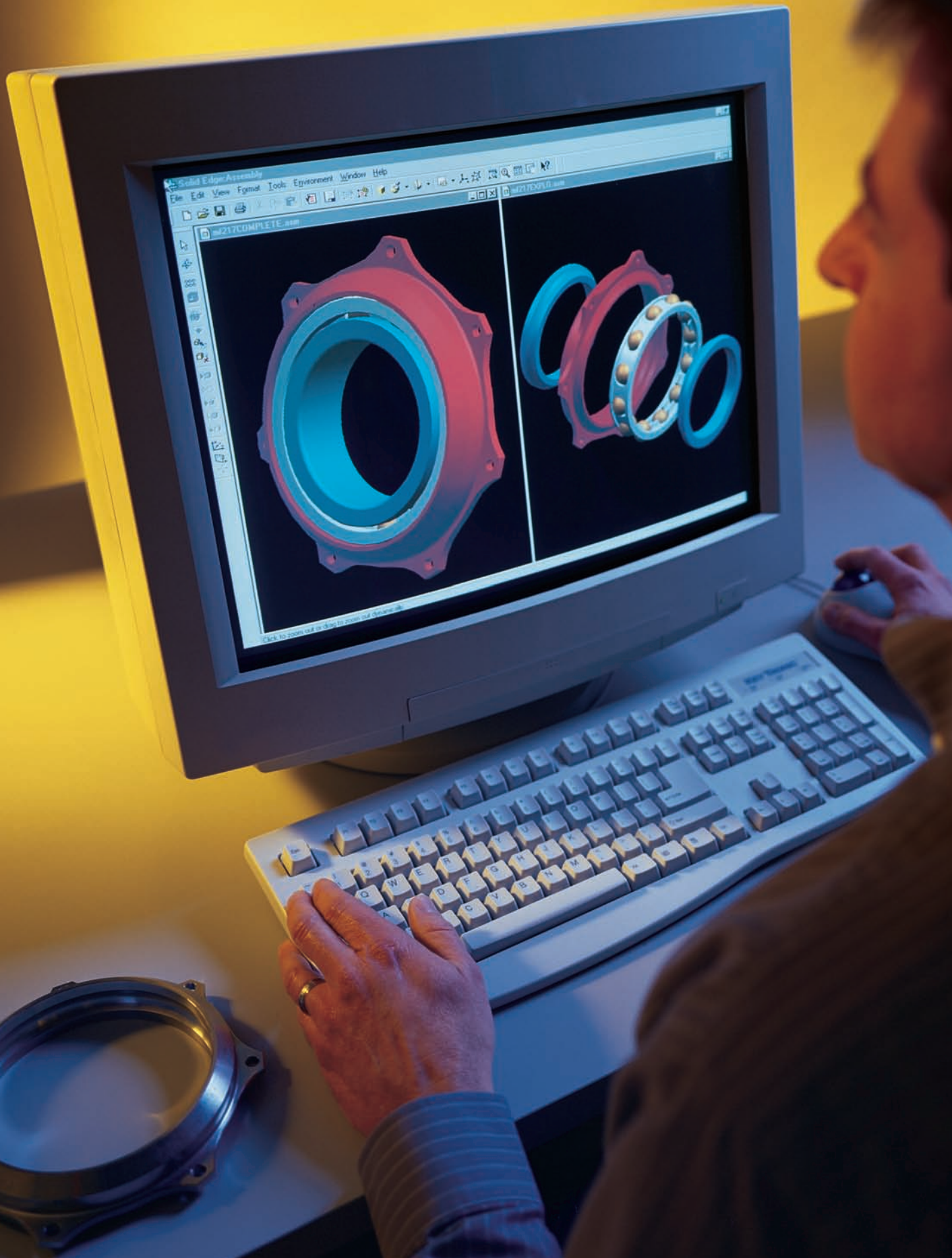
SCB896



Can Seaming Head Roller



# ENGINEERING



# ENGINEERING

## Table of Contents

<b>Bearing Selection</b> .....	69–113
Selecting the Right Bearing .....	69
Operating Conditions .....	69
Bearing Types .....	69
Bearing Size .....	70
Diameter Series .....	71
Sizes and Applications .....	71
Ball and Ring Materials .....	71
Ceramic Hybrids .....	72
X-life Ultra Bearings .....	74
Surface Engineering .....	75
Solid Lubrication .....	76
Bearing Cages .....	77
Deep Groove .....	78
Angular Contact .....	80
Bearing Closures .....	82
Attainable Speeds .....	84
Limiting Speed Factors .....	84
Speedability Factor dN .....	84
Internal Design Parameters .....	85
Ball Complement .....	85
Raceway Curvature .....	85
Radial Internal Clearance .....	85
Contact Angle .....	88
Axial Play .....	90
Ball Complement Tables .....	92
Preloading .....	95
Bearing Yield .....	95
Preloading Techniques .....	95
Spring Preloading .....	95
Axial Adjustment .....	96
Duplex Bearings .....	96
Duplex Mounting Options DB, DF, DT .....	97
Duplex Bearing Spacers .....	98
Lubrication .....	100
Oil Viscosity Graph .....	100
Grease Viscosity Graph .....	101
Barden Lubrication Practices .....	101
Lubricant Selection .....	101
Grease Considerations .....	102
Oil Considerations .....	103
Oil Lubricants .....	103
Grease Lubricants .....	104
Oil Properties .....	105
Oil Types .....	105
Oil Lubrication Systems .....	106
Lubrication Windows .....	106
Tolerances and Geometric Accuracy .....	108
Exclusions From ABEC Standards .....	109
Barden Internal Standards .....	109
Special Tolerance Ranges .....	109
Low Radial Runout Bearings .....	109
Tolerance Tables .....	110
<b>Bearing Performance</b> .....	114–123
Bearing Life .....	114
Service Life .....	114
Bearing Capacity .....	115
Fatigue Life .....	116
Sample Fatigue Life Calculation .....	118
Miscellaneous Life Considerations .....	119
Grease Life .....	120
Vibration .....	121
Yield Stiffness .....	122
Torque .....	122
Measurement and Testing Techniques .....	122
<b>Bearing Application</b> .....	124–143
Mounting and Fitting .....	124
Shaft and Housing Fits .....	125
Fitting Practice .....	125
Fitting Notes .....	126
Shaft and Housing Size Determination .....	127
Maximum Fillet Radii .....	128
Shaft and Housing Shoulder Diameters .....	129
Abutment Tables .....	130
Random and Selective Fitting .....	139
Calibration .....	139
Random vs. Specific Calibration .....	139
Maintaining Bearing Cleanliness .....	141
Handling Guidelines .....	143
Barden Warranty .....	144
Conversion Table .....	144
Literature and Website Information .....	145
Index .....	146

# ENGINEERING

## Bearing Selection

### Selecting the Right Bearing

Selection of a suitable standard bearing – or the decision to utilise a special bearing – represents an effort to deal with performance requirements and operating limitations. Sometimes the task involves conflicts which must be resolved to reach a practical solution.

Making the right choice requires a careful review of all criteria in relation to available options in bearing design. Each performance requirement, such as a certain speed, torque or load rating, usually generates its own specifications which can be compared with available bearing characteristics.

When operating conditions and performance requirements have been formally established, each bearing considered should be reviewed in terms of its ability to satisfy these parameters. If a standard bearing does not meet the requirements, a design compromise will be necessary in either the assembly or the bearing.

At this point, the feasibility of a bearing design change (creation of a special bearing) should be explored with Barden's Product Engineering Department. Consideration of a special bearing should not be rejected out-of-hand, since it can pose an ideal solution to a difficult application problem.

### Operating Conditions

Operating conditions which must be considered in the selection process are listed in Table 1. This is a

convenient checklist for the designer who must determine which items apply to a prospective application, their input values and often their relative importance. Performing this exercise is a useful preliminary step in determining what trade-offs are necessary to resolve the design conflicts.

Among the most important application considerations that must be evaluated are speed and load conditions.

Specific bearing design choices should be based on anticipated operating conditions. Design choices include:

- Materials (rings and balls)
- Bearing size and capacity
- Internal design parameters
- Preloading (duplexing)
- Tolerances & geometric accuracy
- Bearing type
- Closures
- Cages
- Lubrication

### Bearing Types

Barden precision bearings are available in two basic design configurations: Deep groove and angular contact. Design selections between deep groove and angular contact bearings depend primarily upon application characteristics such as:

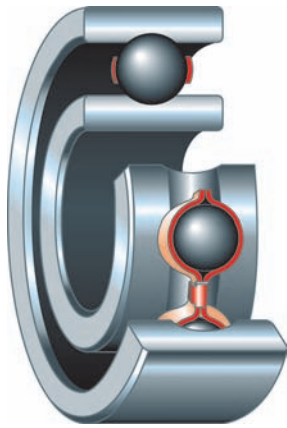
- Magnitude and direction of loading
- Operating speed and conditions
- Lubrication
- Requirements for accuracy and rigidity
- Need for built-in sealing or shielding

**Table 1. Basic operating conditions which affect bearing selection.**

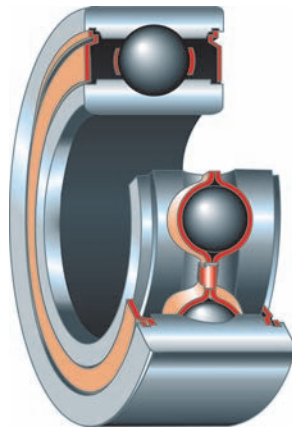
Load	Speed	Temperature	Environment	Shaft and Housing Factors
<b>Direction</b> <ul style="list-style-type: none"> <li>• Radial</li> <li>• Thrust</li> <li>• Moment</li> <li>• Combined</li> </ul> <b>Nature</b> <ul style="list-style-type: none"> <li>• Acceleration (including gravity)</li> <li>• Elastic (belt, spring, etc.)</li> <li>• Vibratory Impact (shock)</li> <li>• Preload</li> </ul> <b>Duty Cycle</b> <ul style="list-style-type: none"> <li>• Continuous</li> <li>• Intermittent</li> <li>• Random</li> </ul>	<b>Constant or Variable</b>  <b>Continuous or Intermittent</b>  <b>Ring Rotation</b> <ul style="list-style-type: none"> <li>• Inner ring</li> <li>• Outer ring</li> </ul>	<b>Average Operating</b>  <b>Operating Range</b>  <b>Differential between rotating and non-rotating elements</b>  <b>Ambient</b>	<b>Air or other gas</b>  <b>Vacuum</b>  <b>Moisture (humidity)</b>  <b>Contaminants</b>	<b>Metallic Material</b> <ul style="list-style-type: none"> <li>• Ferrous</li> <li>• Nonferrous</li> </ul> <b>Non-metallic Material</b> <b>Stiffness</b>  <b>Precision of Mating Parts</b> <ul style="list-style-type: none"> <li>• Size tolerance</li> <li>• Roundness</li> <li>• Geometry</li> <li>• Surface finish</li> </ul>

# ENGINEERING

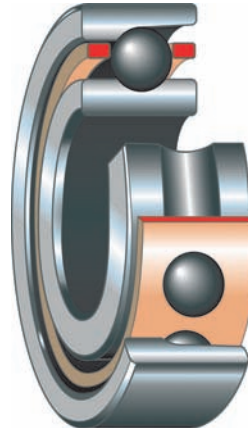
## Bearing Selection



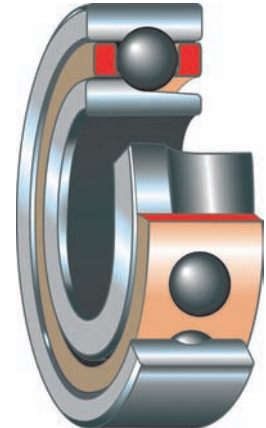
**Deep Groove  
Open**



**Deep Groove  
Shielded**



**Angular Contact  
Non-separable**



**Angular Contact  
Separable**

### Deep Groove

Deep groove ball bearings have full shoulders on both sides of the raceways of the inner and outer rings. They can accept radial loads, thrust loads in either direction, or a combination of loads.

The full shoulders and the cages used in deep groove bearings make them suitable for the addition of closures. Besides single deep groove bearings with closures, Barden also offers duplex pairs with seals or shields on the outboard faces.

Deep groove bearings are available in many sizes, with a variety of cage types. Because of their versatility, deep groove bearings are the most widely used type of bearing.

### Angular Contact

Angular contact bearings have one ring shoulder partially or totally removed. This allows a larger ball complement than found in comparable deep groove bearings, hence a greater load capacity. Speed capability is also greater.

Angular contact bearings support thrust loads or combinations of radial and thrust loading. They cannot accept radial loads only – a thrust load of sufficient magnitude must be present. An individual angular contact bearing can be thrust-loaded in only one direction; this load may be a working load or a preload.

Barden angular contact bearings have a nominal contact angle ranging from 10° to 25°.

Separable and non-separable types are available within

the category of angular contact bearings. In a separable bearing (B type), the cage holds the balls in place so that the outer ring assembly (with cage and balls) can be separated from the inner ring.

Separable bearings are useful where bearings must be installed in blind holes or where press fits are required, both on the shaft and in the housing. The separable feature also permits dynamic balancing of a rotating component with inner ring in place, apart from the outer ring and housing.

### Bearing Size

A variety of criteria will have an influence on bearing size selection for different installations, as follows:

**Mating parts.** Bearing dimensions may be governed by the size of a mating part (e.g. shaft, housing).

**Capacity.** Bearing loading, dynamic and static, will establish minimum capacity requirements and influence size selection because capacity generally increases with size.

**Attainable Speeds.** Smaller bearings can usually operate at higher speeds than larger bearings, hence the speed requirement of an application may affect size selection.

**Stiffness.** Large bearings yield less than small bearings and are the better choice where bearing stiffness is crucial.

**Weight.** In some cases, bearing weight may have to be considered and factored into the selection process.

**Torque.** Reducing the ball size and using wider raceway curvatures are tactics which may be used to reduce torque.

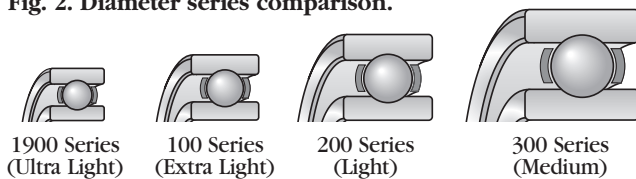
# ENGINEERING

## Diameter Series, Sizes, Materials

### Diameter Series

For spindle and turbine size bearings, most bore diameter sizes have a number of progressively increasing series of outside diameters, width and ball size. This allows further choice of bearing design and capacity. These series are termed Series 1900, 100, 200 and 300 and are shown in the product tables.

**Fig. 2. Diameter series comparison.**



### Sizes and Applications

Barden bearings are sized in both inch and metric dimensions. Overall, metric series bearings range from 4 to 300mm O.D.; inch series from  $\frac{5}{32}$ " to  $11\frac{1}{2}$ " O.D. in standard bearings.

**Table 2. Bearing series size ranges.**

Bearing Category	Catalogue Size Range O.D.	Barden Series
Miniature & Instrument	4mm to 35mm (.1562" to 1.3750")	R, R100, M, 30
Thin Section	16mm to 50mm (.625" to 2.000")	R1000, A500, S500
Spindle & Turbine	22mm to 290mm (.8661" to 11.500")	1900, 100, 200, 300, 9000

Barden bearings are also categorised as miniature and instrument or spindle and turbine types. This distinction is primarily size-related, but is sometimes application-related. For example, a bearing with a one-inch O.D.

**Table 3. Properties of bearing materials.**

Bearing Material	Elastic Modulus ( $\times 10^5$ MPa)	Density (Kg/m <sup>3</sup> )	Poisson's Ratio	Coefficient of Expansion ( $\mu\text{m}/\text{m}/\text{K}$ )	Hardness (Rc)	Temperature Limits (°C)
AISI 440C (M&I)	2.08	7800	0.28	10.3	60-63	150
AISI 440C (S&T)	2.08	7800	0.28	10.3	56-60	315
Ceramic	3.15	3200	0.26	3.1	78	1096
Cronidur 30	2.18	7800	0.26	10.3	58-60	480*
AISI M50	2.08	8000	0.29	11.9	61-64	345
SAE 52100 (M&I)	2.08	7800	0.29	12.0	62-65	177
SAE 52100 (S&T)	2.08	7800	0.29	12.0	58.5-65	200

\*Secondary temper. Consult Barden's Product Engineering Department for details.

is hardly miniature in size, yet it may belong in the miniature and instrument category based on its characteristics and end use. General guidelines used by Barden for classification are in Table 2.

### Ball and Ring Materials

Selection of a material for bearing rings and balls is strongly influenced by availability. Standard bearing materials have been established and are the most likely to be available without delay. For special materials, availability should be determined and these additional factors considered during the selection process:

- Hardness
- Fatigue resistance
- Dimensional stability
- Wear resistance
- Material cleanliness
- Workability
- Corrosion resistance
- Temperature resistance

For all of its ball and ring materials, Barden has established specifications which meet or exceed industry standards. Before any material is used in Barden production, mill samples are analysed and approved. The four predominant ring materials used by Barden are AISI 440C, SAE 52100, AISI M50 and Cronidur 30. The relative characteristics of each are shown in the table below.

AISI 440C is the standard material for instrument bearings. It is optional for spindle and turbine bearings. This is a hardenable, corrosion-resistant steel with adequate fatigue resistance, good load-carrying capacity, excellent stability and wear resistance.

# ENGINEERING

## Materials, Ceramic Hybrid Bearings

SAE 52100 is the standard material for spindle and turbine bearings. It is also available in some instrument sizes, and may be preferable when fatigue life, static capacity and torque are critical. This material has excellent capacity, fatigue resistance and stability. AISI M50 tool steel is suitable for operation up to 345°C, and consequently is widely used in high temperature aerospace accessory applications. Other non-standard tool steels such as T5 and Rex 20 are utilised for high

temperature x-ray tube applications.

Cronidur 30 is a martensitic through-hardened high nitrogen corrosion resistant steel that can also be induction case hardened. The primary difference between AISI 440C and Cronidur 30, for example, is that in Cronidur 30 some of the carbon content has been replaced with nitrogen. This both enhances the corrosion resistance and improves the fatigue life and wear resistance.

### Ceramic Hybrid Bearings

Use of ceramic (silicon nitride) balls in place of steel balls can radically improve bearing performance several ways. Because ceramic balls are 60% lighter than steel balls, and because their surface finish is almost perfectly smooth, they exhibit vibration levels two to seven times lower than conventional steel ball bearings.

Ceramic hybrid bearings also run at significantly lower operating temperatures, allowing running speeds to increase by as much as 40% to 50%. Lower operating temperatures help extend lubricant life. Bearings with ceramic balls have been proven to last up to five times longer than conventional steel ball bearings. Systems equipped with ceramic hybrids show higher rigidity and higher natural frequency making them less sensitive to vibration.

Because of the unique properties of silicon nitride, ceramic balls drastically reduce the predominant cause of surface wear in conventional bearings (metal rings/metal balls). In conventional bearings,

microscopic surface asperities on balls and races will “cold weld” or stick together even under normal lubrication and load conditions. As the bearing rotates, the microscopic cold welds break, producing roughness and, eventually, worn contact surfaces. This characteristic is known as adhesive wear. Since ceramic balls will not cold weld to steel rings, wear is dramatically reduced. Because wear particles generated by adhesive wear are not present in ceramic hybrids, lubricant life is also prolonged. The savings in reduced maintenance costs alone can be significant.



### Ceramic Ball Features

60% lighter than steel balls

- Centrifugal forces reduced
- Lower vibration levels
- Less heat build up
- Reduced ball skidding

50% higher modulus of elasticity

- Improved bearing rigidity
- Naturally fracture resistant

Tribochemically inert

- Low adhesive wear
- Improved lubricant life
- Superior corrosion resistance

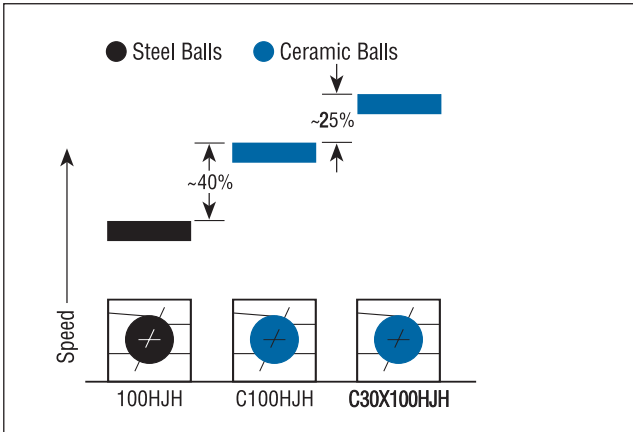
### Benefits of Ceramic Hybrid Bearings

- Bearing service life is two to five times longer
- Running speeds up to 50% higher
- Overall accuracy and quality improves
- Lower operating costs
- High temperature capability
- Electrically non-conductive

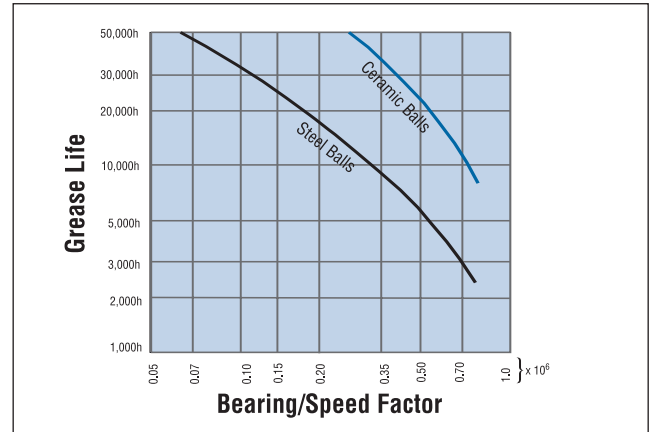


# ENGINEERING

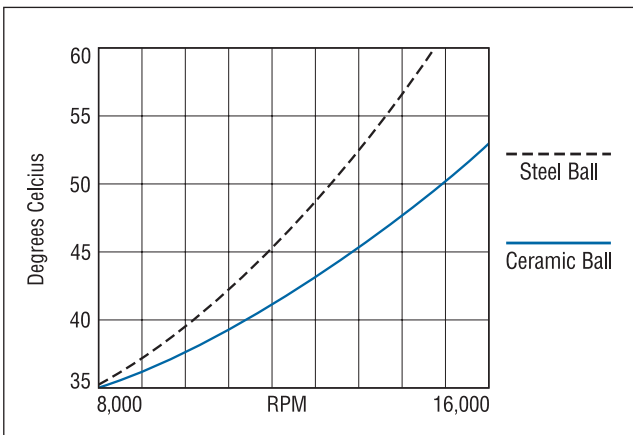
## Ceramic Hybrid Bearings



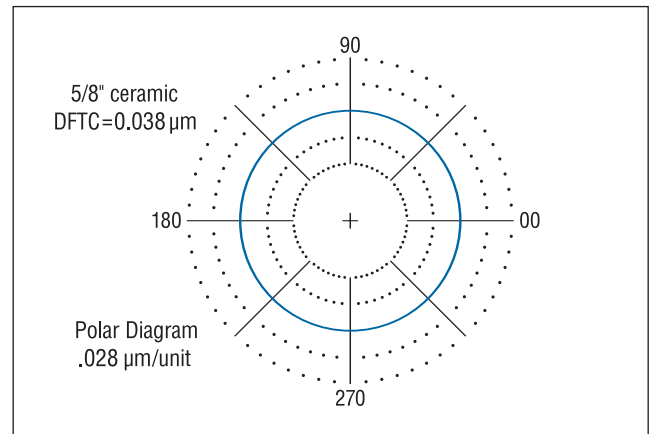
Running speed of ceramic ball exceed same-size steel ball by 40%. Converting to an X-Life Ultra Bearing with ceramic ball will boost running speeds an additional 25%.



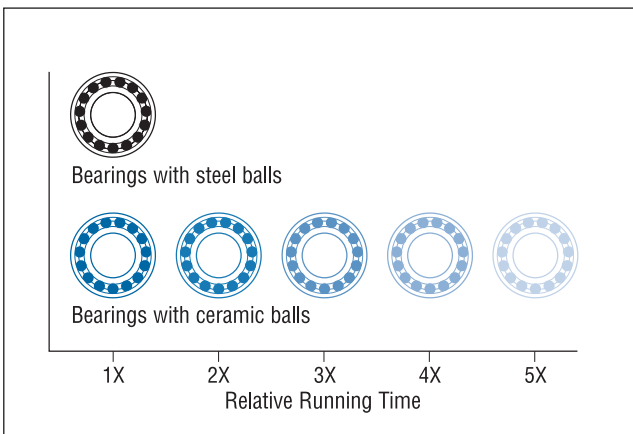
The use of ceramic balls significantly increases bearing grease life performance.



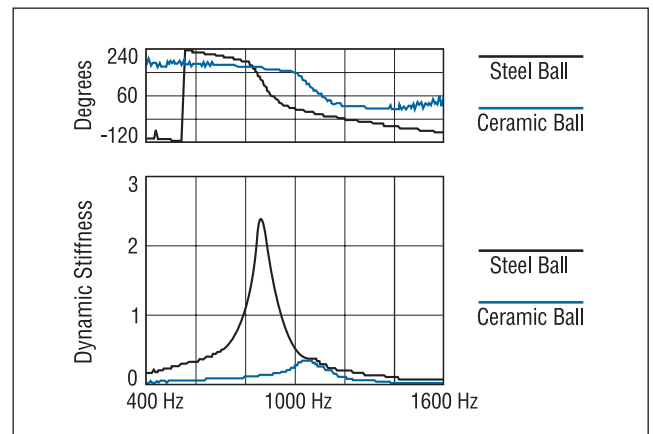
Lower operating temperature. As running speeds increase, ceramic balls always run cooler than conventional steel balls. With reduced heat build up, lubricant life is prolonged.



Deviation from true circularity (DFTC). Polar trace of a 5/8" silicon nitride ball indicates near perfect roundness, which results in dramatically lower vibration levels.



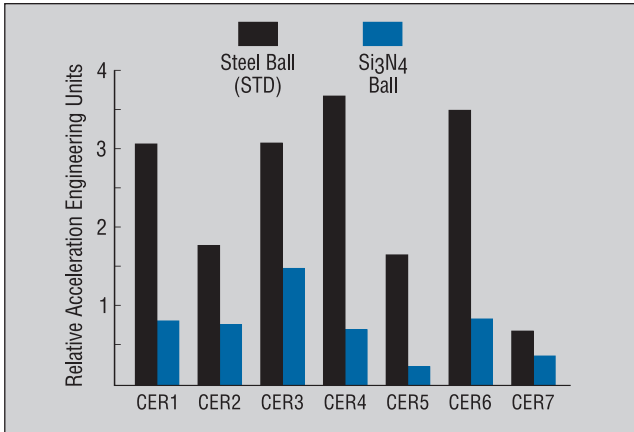
Service life of ceramic hybrid bearings is two to five times that of conventional steel ball bearings, depending upon operating conditions.



Dynamic stiffness analysis shows better rigidity and higher natural frequency for hybrid bearings.

# ENGINEERING

## Ceramic Hybrid Bearings



Vibration tests comparing spindles with steel ball bearings and the same spindle retrofit with ceramic hybrids. Vibration levels averaged two to seven times lower with silicon nitride balls.

Comparison of Bearing Steel & Silicon Nitride Properties		
Property	Steel	Ceramic
Density (Kg/m <sup>3</sup> )	7800	3200
Elastic Modulus (×10 <sup>5</sup> MPa)	2.08	3.15
Hardness	R <sub>c</sub> 60	R <sub>c</sub> 78
Coefficient of thermal expansion (μm/m/K)	12	3.1
Coefficient of friction	0.42 dry	0.17 dry
Poisson's ratio	0.29	0.26
Maximum use temperature (°C)	200	1096
Chemically inert	No	Yes
Electrically non-conductive	No	Yes
Non-magnetic	No	Yes

Ceramic balls are lighter and harder than steel balls, characteristics which improve overall bearing performance.

## X-Life Ultra Bearings

X-Life Ultra bearings were developed for the highest demands with respect to speed and loading capability. These bearings are hybrid ceramic bearings with bearing rings made from Cronidur 30, a high nitrogen, corrosion resistant steel. Cronidur 30 shows a much finer grain structure compared with the conventional bearing steel 100Cr6 (SAE 52100) resulting in cooler running and higher permissible contact stresses. Basically all bearing types are available as X-Life Ultra bearings.

The longer service life of X-Life Ultra bearings when compared to conventional bearings also contributes to an overall reduction in the total system costs. When calculating the indirect costs of frequent bearing replacement – which include not just inventory, but machine down time, lost productivity and labour – the cost savings potential of Cronidur 30 bearings become significant.



X-Life Ultra bearings offer unsurpassed toughness and corrosion resistance. They outlast conventional hybrid bearings up to 4× or more.

# ENGINEERING

## Surface Engineering Technology



*Barden employs surface engineering processes that can provide effective protection against potential friction and wear problems.*

Surface Engineering is the design and modification of a surface and substrate in combination to give cost effective performance enhancement that would not otherwise be achieved. Engineering surfaces are neither flat, smooth nor clean; and when two surfaces come into contact, only a very small percentage of the apparent surface area is actually supporting the load. This can often result in high contact stresses, which lead to increased friction and wear of the component. Engineering the surface to combat friction and reduce wear is therefore highly desirable, and can confer the benefits of lower running costs and longer service intervals.

When challenged by harsh operating conditions such as marginal lubrication, aggressive media and hostile environments, surface engineering processes can provide effective protection against potential friction and wear problems. Working together with recognised leaders in advanced coatings and surface treatments, Barden can provide specialised Surface Engineering Technology in support of the most demanding bearing applications.

### **Wear resistance**

Wear is an inevitable, self-generating process. It is defined as “damage caused by the effects of constant use” and is perhaps the most common process that limits the effective life of engineering components.

Wear is a natural part of everyday life, and in some cases, mild wear can even be beneficial – as with the running in of mechanical equipment. However, it is the severe and sometimes unpredictable nature of wear that is of most concern to industry.

The use of surface engineering processes can effectively reduce the amount of wear on engineering components thereby extending the useful life of the product. Barden utilises a range of hard, wear-resistant coatings and surface treatments to enhance the performance of its super-precision bearing systems.

Common wear resistant treatments include:

- Hard chrome coating
- Electroless nickel plating
- Hard anodising
- Arc evaporated titanium nitride
- Carburising and carbo-nitriding
- Plasma nitriding

### **Anti-Corrosion**

Corrosion can be described as the degradation of material surface through reaction with an oxidising substance. In engineering applications, corrosion is most commonly presented as the formation of metal oxides from exposure to air and water from the environment.

Anti-corrosion processes produce a surface that is less chemically reactive than the substrate material.

Examples include:

- Hard chrome coating
- Galvanised zinc
- Cadmium plating (now being replaced by zinc/nickel)
- Titanium carbide
- Electroless nickel plating
- Titanium nitride
- Passivation treatments

# ENGINEERING

## Surface Engineering Technology

For applications requiring good anti-corrosion performance, Barden also uses advanced material technologies such as with the revolutionary X-Life Ultra high nitrogen steel bearings. In controlled salt-spray tests, X-Life Ultra bearings have shown to give superior corrosion protection to those manufactured from industry standard steels such as AISI 440C. Please contact Barden Product Engineering for further information on X-Life Ultra bearings and their applications.

### Solid Lubrication

From space applications to high-tech medical instruments, solid lubricant films provide effective lubrication in the most exacting of conditions, where conventional oils and greases are rendered inadequate or inappropriate.

Solid lubricated bearings confer distinct advantages over traditional fluid-lubricated systems. Their friction is independent of temperature (from cryogenic to extreme high temperature applications), and they do not evaporate or creep in terrestrial vacuum or space environments.



Photo courtesy of NASA.

*Solid lubrication is intended for use in extreme conditions where greases and oils cannot be used, such as in space environments.*

Solid lubricant films can be generated in one of two basic ways, either by direct application to the surface – for example, sputter-coating of  $\text{MoS}_2$  or by transfer from rubbing contact with a self-lubricating material – as with Barden's BarTemp® polymeric cage material.

The four basic types of solid lubricant film are:

### Soft metals

- Lead, silver, gold, indium

### Lamellar solids

- $\text{MoS}_2$ ,  $\text{WS}_2$ ,  $\text{NbSe}_2$

### Polymers

- BarTemp®, PTFE, Vespel®, Torlon®

### Adventitious layers

- Oils and fats, boundary species

### Summary

A large number of coatings and surface treatments are available to combat friction, corrosion and wear, and it is often difficult for designers to select the optimum process for a particular application. There may even be a range of options available, all of which offer reasonable solutions – the choice is then one of cost and availability.

Through a network of recognised surface engineering suppliers, Barden can offer guidance on the selection of suitable treatments and processes to meet and surpass the demands of your extreme bearing applications.

# ENGINEERING

## Bearing Cages

Proper selection of cage design and materials is essential to the successful performance of a precision ball bearing. The basic purpose of a cage is to maintain uniform ball spacing, but it can also be designed to reduce torque and minimise heat build-up.

In separable bearings, the cage is designed to retain the balls in the outer ring so the rings can be handled separately.

Cage loading is normally light, but acceleration and centrifugal forces may develop and impose cage loading. Also, it may be important for the cage to accommodate varying ball speeds that occur in certain applications.

Cages are piloted (guided) by the balls or one of the rings. Typically, low to moderate speed cages are ball-piloted. Most high-speed cages have machined surfaces and are piloted by the land of either the inner or outer ring.

Barden deep groove and angular contact bearings are available with several types of cages to suit a variety of applications. While cost may be a concern, many other factors enter into cage design and cage selection, including:

- Low coefficient of friction with ball and race materials
- Compatible expansion rate with ball/ring materials
- Low tendency to gall or wear
- Ability to absorb lubricant
- Dimensional and thermal stability
- Suitable density
- Adequate tensile strength
- Creep resistance

This list can be expanded to match the complexity of any bearing application. As a general guide, the tables on pages 78 and 80 may be used by the designer for cage selection. They present basic data in a tabulated format for review and comparison.

When a standard cage does not meet the end use requirements, the Barden Product Engineering Department should be consulted. Barden has developed and manufactured many specialised cages for unusual applications. Some examples of conditions which merit engineering review are ultra-high-speed operation, a need for extra oil absorption, extreme environments and critical low torque situations. Materials as diverse as silver-plated steel, bronze alloys and porous plastics have been used by Barden to create custom cage specifications for such conditions.

### Deep Groove Bearing Cages

The principal cage designs for Barden deep-groove bearings are side entrance snap-in types (Crown, TA, TAT, TMT) and symmetrical types (Ribbon, W, T). Crown and Ribbon types are used at moderate speeds and are particularly suited for bearings with grease lubrication and seals or shields. W-type is a low-torque pressed metal cage developed by Barden, and is available in many instrument sizes. This two-piece ribbon cage is loosely clinched to prevent cage windup (a torque increasing drawback of some cage designs) in sensitive low-torque applications.

For higher speeds, Barden offers the one-piece phenolic snap-in TA-type cage in smaller bearing sizes and the two-piece riveted phenolic, aluminum-reinforced T cage for larger sizes. The aluminum reinforcement, another Barden first, provides additional strength, allowing this high-speed cage to be used in most standard width sealed or shielded bearings.

### Angular Contact Bearing Cages

In Barden miniature and instrument angular contact bearings, (types B and H), machined phenolic cages with high-speed capability are standard. These cages are outer ring land guided, which allows lubricant access to the most desired point – the inner ring/ball contact area. Centrifugal force carries lubricant outward during operation to reach the other areas of need.


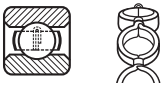
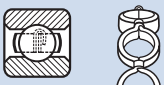
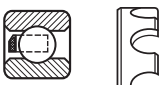




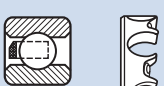

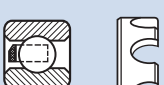
H-type phenolic cages are of a through-pocket halo design. The B-type cage used in separable bearings has ball pockets which hold the balls in place when the inner ring is removed.

For high-temperature applications, the larger spindle and turbine bearing cages are machined from bronze or steel (silver plated). Most of these designs are also outer ring land guided for optimum bearing lubricant access and maximum speedability.

Many non-standard cage types have been developed for specific applications. These include cages from porous materials such as sintered nylon or polyimide, which can be impregnated with oil to provide reservoirs for extended operational life.

# ENGINEERING

## Deep Groove Bearing Cages

CAGES FOR DEEP GROOVE BEARINGS					Maximum Speed in dN units		Operating Temperature Range	Limitations
Type	Illustration	Use	Material	Construction	Oil Lubrication	Grease Lubrication		
<b>Q</b> Crown type, snap cage		General purpose	Stainless steel AISI 410	One-piece, stamped, with coined ball pockets and polished surfaces	250,000	250,000	Normal up to 600°F (315°C)	Up to SR168, SR4 and S19M5
<b>P</b> Two-piece ribbon cage, full clinch		General purpose	Stainless steel AISI 430 AISI 305	Two-piece, stamped ribbons to form spherical ball pockets, with full clinch on ears	250,000	250,000	Normal up to 900°F (482°C)	None (not used on bearings with bore smaller than 5mm)
<b>W</b> Two-piece ribbon cage, loosely clinched		General purpose, low torque peaking	Stainless steel AISI 430 AISI 305	Two-piece, stamped ribbons to form ball pockets, with loosely clinched ears	250,000	250,000	Normal up to 900°F (482°C)	None
<b>TA</b> One-piece snap cage, synthetic		High speed, general purpose	Fibre reinforced phenolic (type depends on cage size)	One-piece, machined side assembled snap-in type	600,000	600,000	Normal up to 300°F (149°C)	None
<b>T</b> Two-piece riveted synthetic		High speed, general purpose	Fibre reinforced phenolic/aluminum	Two-piece, machined from cylindrical segments of phenolic, armoured with aluminum side plates, secured with rivets	1,200,000	850,000	Normal up to 300°F (149°C)	No contact with chlorinated solvents
<b>ZA</b> Tube type ball separator		Low speed, low torque, may be used without lubrication	Teflon®	Hollow cylinders of Teflon	5,000	5,000	Cryogenic to 450°F (232°C)	If used without lubricant, bearing material must be stainless steel
<b>TB</b> Crown type snap cage synthetic		Light load, no lube, in stainless steel bearing only, high & low temp. moderate speed	BarTemp®	One-piece, machined, side assembled, snap-in type	60,000*	—	Cryogenic to 575°F (302°C)	Use only with stainless steel, no lube. Requires shield for cage retention. Moisture sensitive. Avoid hard preload.
<b>TQ</b> Crown type snap cage synthetic		High speed, quiet operation	Delrin	One-piece machined, side assembled, snap-in type	600,000	600,000	Normal up to 150°F (66°C)	Low oil retention. Needs continuous or repetitive lubrication when oil is used. Unstable colour.
<b>TMT</b> Crown type snap cage synthetic		Moderate speed, general purpose	Filled nylon 6/6	One-piece moulded, snap-in type with spherical ball pockets 100, 200 & 300 series	300,000	300,000	Normal up to 300°F (149°C)	None
<b>TAT</b> Crown type snap cage synthetic		Moderate to high speed, general purpose	Fibre reinforced plastic	One-piece machined snap-in type 100 and 200 series	400,000	400,000	Normal up to 300°F (149°C)	None
<b>TGT</b> Crown type snap cage synthetic		Moderate to high speed, general purpose	High temperature plastic	One-piece machined, snap-in type	600,000	600,000	Normal up to 397°F (203°C)	None

Maximum speed limits shown are for cage comparison purposes only. See the product section for actual bearing speedability. \* Max 'dN' dry

# ENGINEERING

## Deep Groove Bearing Cages



TYPE Q



TYPE T



TYPE TMT



TYPE P



TYPE ZA



TYPE TAT



TYPE W



TYPE TB



TYPE TGT



TYPE TA



TYPE TQ

# ENGINEERING

## Bearing Selection — Angular Contact Bearing Cages

CAGES FOR ANGULAR CONTACT BEARINGS					Maximum Speed in dN units		Operating Temperature Range	Limitations
Type	Illustration	Use	Material	Construction	Oil Lubrication	Grease Lubrication		
<b>B*</b> One-piece, for bearings with separable inner rings		High speed, general purpose	Fibre reinforced phenolic	One-piece, machined from fibre-reinforced phenolic resin – conical or cylindrical stepped ball pockets to retain balls	1,200,000	1,000,000	Normal up to 300°F (149°C)	None
<b>H**</b> One-piece, for bearings with non-separable inner rings		High speed, general purpose	Fibre reinforced phenolic	One-piece design, machined from fibre-reinforced phenolic resin – with cylindrical ball pockets	1,200,000	1,000,000	Normal up to 300°F (149°C)	None
<b>HJB**</b> One-piece, for bearings with non-separable inner rings		High speed, high temperature	Bronze (80-10-10)	One-piece machined cylindrical pockets	1,500,000	Not recommended	Normal up to 625°F (329°C)	Continuous or repetitive lubrication required. Stains with synthetic oil.
<b>HJH**</b> One-piece, for bearings with non-separable inner rings		High speed, high temperature	Bronze (80-10-10)	One-piece machined cylindrical pockets	1,500,000	Not recommended	Normal up to 625°F (329°C max)	Continuous or repetitive lubrication required. Stains with synthetic oil.
<b>HGH**</b> One-piece, for bearings with non-separable inner rings		High speed, general purpose	High temperature plastic	One-piece machined cylindrical pockets	1,200,000	1,000,000	Normal up to 397°F (203°C)	None
<b>JJJ</b> One-piece, for bearings with non-separable inner rings		High speed, high temperature	Bronze (80-10-10)	One-piece machined with press formed pockets	1,500,000	Not recommended	Normal up to 625°F (329°C max)	Continuous or repetitive lubrication required. Stains with synthetic oil.
<b>Four examples of other cage types, without designation, which would be specified under a special 'X' or 'Y' suffix.</b>								
<b>Toroidal separator for bearings which are non-separable</b>		Low speed, low torque, may be used without lubrication	Teflon	Toroidal rings of Teflon encircling alternate balls	5,000	Not recommended	Cryogenic to 450°F (232°C)	If used without lubricant, bearing material must be stainless steel.
<b>One-piece, for bearings which are non-separable</b>		High speed, high temperature	Silver plated steel	One-piece machined cylindrical pockets silver plated	1,500,000	Not recommended	Normal up to 650°F (345°C)	Continuous or repetitive lubrication required. Stains with synthetic oil.
<b>One-piece, for bearings which are both separable and non-separable</b>		Moderate speed	Porous nylon	One-piece machined from sintered nylon cylindrical pockets or cylindrical stepped pockets	150,000	Not recommended	Normal up to 203°F (95°C)	Not suitable for very wide temperature ranges due to high thermal expansion characteristic.
<b>One-piece, for bearings which are both separable and non-separable</b>		Moderate speed	Porous polyimide	One-piece machined from sintered polyimide cylindrical pockets or cylindrical stepped pockets	150,000	Not recommended	Normal up to 600°F (315°C)	None

Maximum speed limits shown are for cage comparison purposes only. See the product section for actual bearing speedability.

\*Bearing type designation with standard cage: do not repeat in bearing number.

\*\*Letter 'H' denotes bearing type — do not repeat 'H' in bearing number.





# ENGINEERING

## Bearing Selection — Angular Contact Bearing Cages



TYPE B



TYPE H



TYPE HJB



TYPE HJH



TYPE HGH



TYPE JJJ



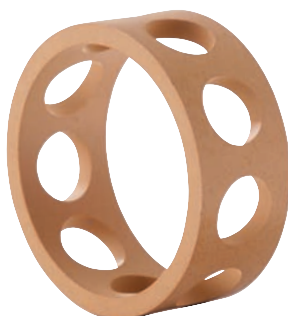
TEFLON TOROIDS



SILVER PLATED STEEL



POROUS NYLON



POROUS POLYIMIDE

# ENGINEERING

## Deep Groove Bearing Closures

The two basic types of bearing closures are shields and seals, both of which may be ordered as integral components of deep groove bearings.

All closures serve the same purposes with varying effectiveness. They exclude contamination, contain lubricants and protect the bearing from internal damage during handling.

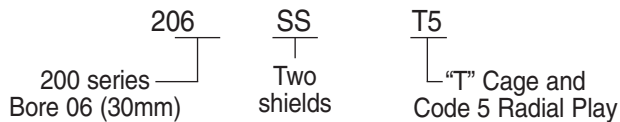
Closures are attached to the outer ring. If they contact the inner ring, they are seals. If they clear the inner ring, they are shields. Seals and shields in Barden bearings are designed so that the stringent precision tolerances are not affected by the closures. They are available in large precision spindle and turbine bearings as well as in Barden instrument bearings.

### Closures Nomenclature

In the Barden nomenclature, closures are designated by suffix letters:

- S – (Shield)
- U – (Synchroseal™)
- A – (Barshield™)
- Y, P, V – (Barseal™)
- F – (Flexeal™)

Usually two closures are used in a bearing, so the callout is a double letter e.g. “FF”, “SS” etc. The closure callout follows the series-size and bearing type.



### Selection of Closures

Determining the proper closure for an application involves a tradeoff, usually balancing sealing efficiency against speed capability and bearing torque.

Shields do not raise bearing torque or limit speeds, but they have low sealing efficiency. Seals are more efficient, but they may restrict operating speed and increase torque and temperature.

Another consideration in closure selection is air flow through the bearing which is detrimental because it carries contamination into the bearing and dries out the lubricant. Seals should be used if air flow is present.



Shield (SS)



Barshield (AA), Buna-N Barseal (YY)



Flexeal (FF)



Synchroseal (UU)



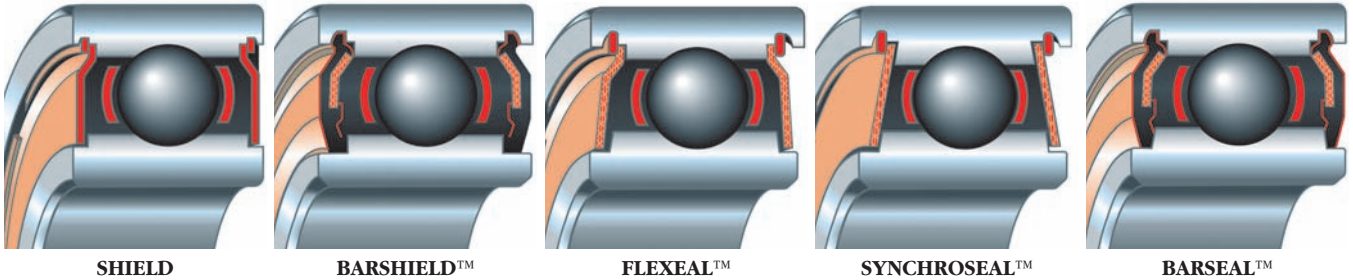
Polyacrylic Barseal (PP)



Viton® Barseal (VV)

# ENGINEERING

## Deep Groove Bearing Closures



CLOSURES FOR DEEP GROOVE BEARINGS					Maximum Speed	Operating Temperature Range	Limitations
Type	Use	Material	Construction	Benefits	(dN units)		
<b>SS Shields</b>	Low torque, high speed closure that can provide lubricant retention and limited contamination protection	302 Stainless steel	Precision stamping	Maximum lubricant space, resistance to vibration	Not limited by shield design	315°C 600°F	Limited contamination protection
<b>AA Barshield</b>	High speed rubber shield that provides improved protection from contamination without reducing allowable operating speeds	Rubber, metal insert	Rubber material bonded to metal stiffener	Good exclusion of contamination without a reduction in operating speed	Not limited by shield design	-38°C to 107°C -30°F to 225°F	May not prevent entrance of gases or fluids
<b>FF Flexeals</b>	Minimum torque, low friction seal that provides lubricant retention and contamination protection	Aluminum/fiber laminate	Precision stamping & bonding	Excellent exclusion of contamination, resistance to aircraft hydraulic fluids	650,000	150°C/300°F continuous 176°C/350°F intermittent	May not prevent entrance of gases or fluids
<b>UU Synchro seal</b>	Specialised seal suitable for low torque applications	Teflon filled fiber glass	Thin ring, piloted in a specially designed inner ring notch	Low torque, positive seal that can prevent the entrance of solid, gaseous or liquid contamination	100,000	315°C 600°F	Limited to low speed operation
<b>YY Buna-N-Barseal</b>	YY closures provide improved sealing performance compared to Flexeals	Buna-N rubber, metal insert	Rubber material bonded to metal stiffener	Excellent positive sealing to prevent the entrance of foreign contaminants	180,000	-54°C to 107°C -65°F to 225°F	Limited to relatively low speed and temperature operation
<b>PP Polyacrylic Barseal</b>	Polyacrylic Barseals provide a positive seal and allow for higher temperature operation than YY seals	Polyacrylic rubber, metal insert	Rubber material bonded to metal stiffener	Excellent positive sealing to prevent the entrance of foreign contaminants	180,000	-21°C to 130°C -5°F to 265°F	Requires relatively low speed operation
<b>V V Viton Barseal</b>	While similar in design to YY and PP seals, V V seals provide for high temperature operation	Viton rubber, metal insert	Rubber material bonded to metal stiffener	Excellent positive sealing to prevent the entrance of foreign contaminants	180,000	-40°C to 288°C -40°F to 550°F	Viton material provides excellent thermal and chemical properties and is the material of choice for aerospace bearings

Maximum speed limits shown are for seal comparison purposes only. See the product section for actual bearing speedability.

# ENGINEERING

## Attainable Speeds and Limiting Speed Factors

### Attainable Speeds

Attainable speed is defined as the speed at which the internally generated temperature in a mounted bearing reaches the lowest of the maximum temperatures permissible for any one of its components, including the lubricant.

Attainable speeds shown in the Product Tables are values influenced by bearing design and size; cage design and material; lubricant type, quantity and characteristics; type of lubrication system; load; alignment and mounting. With so many interactive factors, it is difficult to establish a definitive speed limit. The listed values in this catalogue represent informed judgments based on Barden experience.

Each listed attainable speed limit assumes the existence of proper mounting, preloading and lubrication. For an oil-lubricated bearing, an adequate oil jet or air/oil mist lubrication system should be used. For a grease-lubricated bearing, the proper type and quantity of grease should be used (see pages 100–107). When the actual operating speed approaches the calculated limiting speed, Barden Product Engineering should be contacted for a thorough application review.

Mounting and operating conditions which are less than ideal will reduce the published speed limits. Limiting speed factors for preloaded bearings with high speed cages are shown in Table 4. They may be used to modify listed values to reflect various application conditions. Increasing stiffness by replacing a spring preload with a rigid (or solid) preload by means of axial adjustment also reduces the speed potential. Barden Product Engineering will be pleased to assist in evaluating the effects on performance for specific applications.

**Table 4. Speed factors applicable to all series with high speed retainers — B, T, H, HJB, HJH, and JJJ.**

Type of Preload	Speed Factors		
	L (Light)	M (Medium)	H (Heavy)
<b>Spring Load or Preload</b>			
<b>Single Bearings</b> (Spring Loaded)	*	1.0	—
<b>Duplex Pairs</b>			
DB	0.75	0.66	0.35
DF	0.65	0.50	0.30
<b>Tandem Pairs</b> (Spring Loaded)	*	0.90	—

\*Spring-preloaded bearings require preloads heavier than L at limiting speeds.

### Limiting Speed Factors

Table 4 applies to both deep groove and angular contact bearings. Applicable to all series of deep groove and angular contact bearings with ultra high speed cages, B, H, HJB, HJH, JJJ and T. These factors are applied to limiting speeds shown in the Product Section.

**Example:** An existing application has a turbine running at 16,000 rpm using 211HJH tandem pairs with oil lubrication. Can speed be increased? And if so, to what value?

Step 1: Obtain oil lubricated base attainable speed from product table, page 47 . . . . .27,200 rpm

Step 2: Multiply by factor for medium DT preload from Table 4 . . . . .0.9

Answer: Modified speed . . . . .24,480 rpm

Therefore spindle speed can be increased to approximately 24,480 rpm.

**Example:** Find limiting speed for a duplex pair of 206 deep groove bearings with Flexeals, grease lubrication and medium DB preload (Bearing Set #206FT5DBM G-42).

Step 1: Obtain grease lubricated base limiting speed from product table, page 31 . . . . .28,333 rpm

Step 2: Multiply by factor for medium DB preload from Table 4: . . . . .0.66

Answer: Modified limiting speed . . . . .18,699 rpm

### Speedability Factor dN

In addition to rpm ratings, ball bearings may also have their speed limitations or capabilities expressed in dN values, with dN being:

$$dN = \text{bearing bore in mm multiplied by speed in rpm.}$$

This term is a simple means of indicating the speed limit for a bearing equipped with a particular cage and lubricant. For instance, angular contact bearings which are grease-lubricated and spring-preloaded should be limited to approximately 1,000,000 dN. Deep groove bearings with metal cages should not exceed approximately 250,000 dN, regardless of lubricant.

# ENGINEERING

## Internal Design Parameters and Radial Internal Clearance

### Internal Design Parameters

The principal internal design parameters for a ball bearing are the ball complement (number and size of balls), internal clearances (radial play, axial play and contact angle), and raceway curvature.

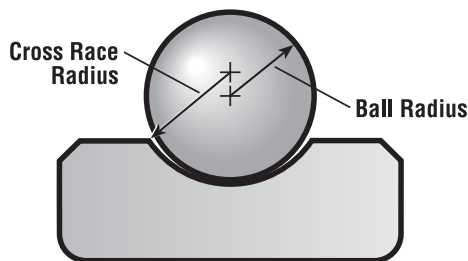
### Ball Complement

The number and size of balls are generally selected to give maximum capacity in the available space. In some specialised cases, the ball complement may be chosen on a basis of minimum torque, speed considerations or rigidity.

### Raceway Curvature

The raceway groove in the inner and outer rings has a cross race radius which is slightly greater than the ball radius (see Fig. 3). This is a deliberate design feature which provides optimum contact area between balls and raceway, to achieve the desired combination of high load capacity and low torque.

Fig. 3. Raceway curvature.



### Radial Internal Clearance

Commonly referred to as radial play, this is a measure of the movement of the inner ring relative to the outer ring, perpendicular to the bearing axis (Fig. 4). Radial play is measured under a light reversing radial load then corrected to zero load. Although often overlooked by designers, radial play is one of the most important basic bearing specifications. The presence and magnitude of radial play are vital factors in bearing performance. Without sufficient radial play, interference fits (press fits) and normal expansion of components due to temperature change and centrifugal force cannot be accommodated, causing binding and early failure.

The radial internal clearance of a mounted bearing has a profound effect on the contact angle, which in turn influences bearing capacity, life and other performance characteristics. Proper internal clearance will provide a suitable contact angle to support thrust loads or to meet exacting requirements of elastic yield.

High operating speeds create heat through friction and require greater than usual radial play. Higher values of radial play are also beneficial where thrust loads predominate, to increase load capacity, life and axial rigidity. Low values of radial play are better suited for predominately radial support.

Deep groove bearings are available from Barden in a number of radial play codes, each code representing a different range of internal radial clearance, (see Tables on pages 86 and 87). The code number is used in bearing identification, as shown in the Nomenclature section.

The available radial play codes are listed in the following tables. These radial play codes give the designer wide latitude in the selection of proper radial internal clearance. It should be noted here that different radial play codes have nothing to do with ABEC tolerances or precision classes, all Barden bearings are made to ABEC 7 or higher standards and the radial play code is simply a measure of internal clearance.

Specifying a radial code must take into account the installation practice. If a bearing is press fitted onto a shaft or into a housing, its internal clearance is reduced by up to 80% of the interference fit. Thus, an interference fit of .006mm could cause a .005mm decrease in internal clearance.

Deep groove bearings with Code 3 and Code 5 radial play are more readily available than those with other codes. When performance requirements exceed the standard radial play codes, consult the Barden Product Engineering Department. Special ranges of internal clearance can be supplied, but should be avoided unless there is a technical justification.

Angular contact bearings make use of radial play, combined with thrust loading, to develop their primary characteristic, an angular line of contact between the balls and both races.

# ENGINEERING

## Radial Internal Clearance

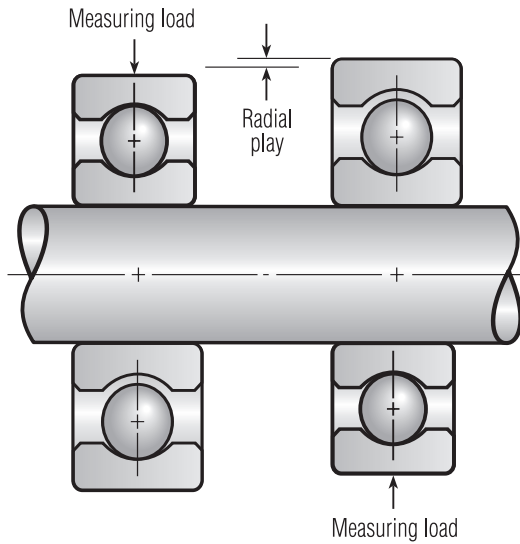


Fig. 4. Radial play is a measure of internal clearance and is influenced by measuring load and installation practices. A high radial play value is not an indication of lower quality or less precision.

Table 5A. Radial play range of deep groove instrument bearings for various radial play codes.

Basic Bearing Type	Radial Play Codes				
	2	3	4	5	6
Deep Groove Instrument (Inch)	.0025	.005	.0075	.0125	.020
Deep Groove Instrument (Metric)	to	to	to	to	to
Deep Groove Flanged (Inch)	.0075	.010	.0125	.020	.028
Deep Groove Thin Section (Inch) SR1000 Series	—	—	—	.0075 to .020	.0125 to .025
Deep Groove Thin Section (Inch) 500 Series	—	—	—	.0125 to .028	.020 to .036

All dimensions in millimeters.

Table 5B. Radial play code selection guide for deep groove instrument bearings.

Performance Requirements	Loads and Speeds	Recommended Radial Play Code	Limitations
Minimum radial clearance without axial adjustment.	Light loads, low speeds.	3	Lowest axial load capacity. Highest torque under thrust. Not suitable for hot or cold running applications. Must not be interference fitted to either shaft or housing.
Internal clearance not critical; moderate torque under thrust loading.	Moderate loads and speeds.	3	Axial adjustment for very low speed or axial spring loading for moderate speed may be necessary.
Minimum torque under thrust loading; endurance life under wide temperature range.	Moderate to heavy loads, very low to high speeds.	5	Axial adjustment, spring preloading or fixed preloads usually required; light interference fits permissible in some cases.
Specific requirements for axial and radial rigidity; high thrust capacity at extreme speeds and temperatures.	Moderate to heavy loads at high speeds.	Consult Barden.	Complete analysis of all performance and design factors is essential before radial play specification.

Table 6. Available radial play ranges for angular contact instrument bearings.

Basic Bearing Number	Radial Play Codes			
	Standard (No Code)	4	5	6
SR2B	.0075 – .028	—	—	—
SR2H	.0075 – .013	—	—	—
SR3B, SR4B	.013 – .036	—	—	—
SR3H, SR4H, SR4HX8	.0075 – .015	—	.013 – .020	—
34BX4, 34 – 5B, 36BX1	.015 – .041	—	—	—
34 – 5H	.013 – .020	.0075 – .013	.013 – .030	.020 – .028
36H, 38H, 39H	.013 – .020	—	.013 – .020	.020 – .028
38BX2	.018 – .043	—	—	—

All dimensions in millimeters.

# ENGINEERING

## Radial Internal Clearance

**Table 7. Radial play code selection guide for deep groove spindle and turbine bearings.**

Performance Requirements	Loads and Speeds	Recommended Radial Play Code	Limitations
Axial and radial rigidity, minimum runout.	Light loads, high speeds.	Consult Barden.	Complete analysis of all performance and design factors is essential before radial play specification.
Axial and radial rigidity, low runout.	Heavy loads, low to moderate speeds.	5	Axial adjustment, spring preloading or fixed preloading is usually required; interference fits required on rotating rings.
Minimum torque, maximum life under wide temperature range.	Moderate.	5 or 6	May require spring preloading; usually interference fitted on rotating ring.

**Table 8. Radial play ranges of Barden deep groove spindle and turbine bearings for various radial play codes.**

Basic Bearing Number	Radial Play Codes		
	3	5	6
100 – 103	.005 – .010	.013 – .020	.020 – .028
104 – 107	.005 – .013	.013 – .023	.023 – .036
108	.005 – .013	.018 – .030	.030 – .043
109 – 110	.010 – .020	.020 – .033	.033 – .048
111	.013 – .025	.025 – .041	.041 – .058
200 – 205	.005 – .013	.013 – .023	.023 – .036
206 – 209	.005 – .013	.018 – .030	.030 – .043
210	.010 – .020	.020 – .033	.033 – .048
211 – 213	.013 – .025	.025 – .041	.041 – .058
214 – 216	.013 – .028	.028 – .048	.048 – .069
217 – 220	.015 – .033	.033 – .056	.056 – .081
221 – 224	.018 – .038	.038 – .064	.064 – .094
226 – 228	.020 – .046	.046 – .076	.076 – .109
230 – 232	.020 – .051	.051 – .086	.086 – .124
300 – 303	.005 – .010	.013 – .020	.020 – .028
304	.008 – .018	.015 – .025	.023 – .036
305 – 306	.008 – .018	.015 – .025	.025 – .038
307 – 308	.008 – .018	.018 – .030	.030 – .043
309 – 310	.010 – .020	.020 – .033	.033 – .048
311 – 313	.013 – .025	.025 – .041	.041 – .058
314 – 316	.013 – .028	.028 – .048	.048 – .069
317 – 320	.015 – .033	.033 – .056	.056 – .081
322 – 324	.018 – .038	.038 – .064	.064 – .094

All dimensions in millimeters.

**Table 9. Radial play ranges of Barden 100 B-Type separable 15° angular contact bearings.**

Basic Bearing Number	Radial Play Range	Basic Bearing Nomenclature	Radial Play Range
101B, 102B, 103B	.020 – .030	108B	.043 – .053
104B, 105B	.030 – .041	110B	.046 – .058
106B	.033 – .043	113B	.053 – .069
107B	.038 – .048	117B	.069 – .089

All dimensions in millimeters.

**Table 10. Radial play ranges of Barden 1900H, 100H, 200H, 300H series 15° angular contact bearings.**

Basic Bearing Number	Radial Play Range
1900H, 1901H, 1902H, 1903H	.010 – .020
1904H, 1905H, 1906H, 102H, 105H	.015 – .025
1907H, 100H, 101H, 103H, 106H, 200H	.018 – .028
107H, 201H, 202H, 203H	.020 – .030
108H, 301H	.020 – .033
302H, 303H	.023 – .036
104H	.025 – .036
109H, 110H	.025 – .038
204H, 205H	.028 – .038
206H, 304H	.028 – .043
111H, 112H, 113H	.030 – .046
207H, 208H, 209H, 305H	.030 – .043
114H, 115H, 210H	.036 – .051
306H	.036 – .056
116H, 117H, 211H, 307H	.038 – .058
118H, 119H, 120H, 212H, 308H	.043 – .064
213H, 214H, 215H, 309H	.051 – .071
310H	.053 – .079
216H	.056 – .076
217H	.058 – .084
218H	.066 – .091
219H, 220H	.076 – .102

All dimensions in millimeters.

# ENGINEERING

## Contact Angle

### Contact Angle

Contact angle is the nominal angle between the ball-to race contact line and a plane through the ball centers, perpendicular to the bearing axis (see Fig. 5). It may be expressed in terms of zero load or applied thrust load. The unloaded contact angle is established after axial takeup of the bearing but before imposition of the working thrust load. The loaded contact angle is greater, reflecting the influence of the applied thrust load. Each radial play code for Barden deep groove bearings has a calculable corresponding contact angle value.

Angular contact bearings, on the other hand, are assembled to a constant contact angle by varying the radial clearance. Spindle size Barden angular contact bearings have nominal contact angles of 15°.

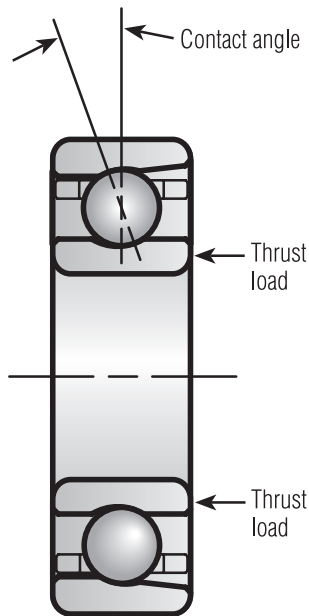


Fig. 5. Contact angle refers to the nominal angle between the ball-to-race contact line and a plane through the ball centers, perpendicular to the bearing axis.

Table 11. Initial contact angles for deep groove miniature and instrument and thin section bearings.

Basic Bearing Number	Radial Play Codes				
	2	3	4	5	6
	Initial Contact Angle, Degrees				
SR0, SR133	12.3	15.1	17.3	22.2	26.9
SR1, SR1-4, SR143, SR144, SR144X3, SR154X1, SR155, SR156, SR156X1, SR164, SR164X3, SR168, SR174X2, SR174X5, SR184X2, SR2X52	10.9	13.4	15.5	19.8	24.0
SR1-5, SR2, SR2A, SR2-5, SR2-6, SR2-5, SR2-6, SR2-5X2, SR166, SR186X2, SR186X3, SR188, SR1204X1, SR1810	8.7	10.7	12.2	15.7	19.0
SR3, SR3X8, SR3X23, SR4, SR4X35	7.1	8.7	10.0	12.8	15.5
SR4A	5.8	7.1	8.1	10.4	12.6
SR6	5.5	6.7	7.7	9.9	12.0
SR8	11.3	13.7	15.8	20.2	24.2
SR10	11.0	13.3	15.3	19.6	23.5
S18M1-5, S19M1-5, S19M2-5	12.3	15.1	17.3	22.2	26.9
S19M2, S38M2-5	10.9	13.4	15.5	19.8	24.0
S38M3	10.2	12.4	14.3	18.3	22.0
S2M3, S18M4, S38M4	8.7	10.7	12.2	15.7	19.0
S2M4	7.1	8.7	10.0	12.8	15.5
34, 34-5	6.2	7.5	8.7	11.1	13.3
35, 36	5.8	7.1	8.1	10.4	12.6
S18M7Y2	7.8	9.4	10.9	13.9	16.8
37, 38	5.5	6.7	7.7	9.9	12.0
37X2, 38X2, 38X6	11.3	13.9	16.0	20.5	24.8
39	10.9	13.2	15.2	19.4	23.6
A538 to A543	—	—	—	22.2	26.9
S538 to S543	—	—	—	17.4	20.4
SR1012, SR1216, SR1624	—	—	—	15.7	19.0



# ENGINEERING

## Contact Angle

**Table 12. Initial contact angles for deep groove spindle and turbine bearings.**

Basic Bearing Number	Radial Play Codes		
	3	5	6
	Initial Contact Angle, Degrees		
100	13.3	19.6	23.7
100X1	8.7	12.8	15.5
101	10.8	16	19.3
101X1	13.3	19.6	23.7
102	11.5	16.9	20.5
103	13.3	19.6	23.7
104	9.2	13	16.8
105	10.7	15.2	19.5
106	8.6	12.2	15.7
107	7.8	11.1	14.2
108	9.6	15.9	19.6
109, 110	11.5	15.2	18.8
111	11.9	15.7	19.2
200	11.5	16.3	20.9
201, 201X1	11.1	15.7	20.2
202, 202X1	10.7	15.2	19.5
203	10.4	14.8	18.9
204, 9204, 205, 9205	9.6	13.6	17.5
206, 9206	8.8	14.5	17.9
207, 9207	8.1	13.4	16.6
208, 9208, 209, 9209	7.8	12.9	16
210	9.9	13.2	16.3
211	10.4	13.7	16.9
213	9.9	13.1	16.1
222	9.0	12.1	15.1
232	8.5	12.7	15.9
303	7.6	11.0	13.5
305	9.7	12.3	15.4
306	9.3	11.8	14.8
307	8.5	11.7	14.5
308	8.1	11.2	13.8
309	8.5	11.2	13.9
310	8.1	10.7	13.3
311	8.7	11.5	14.1
312	8.4	11.1	13.6
313	8.1	10.7	13.1
316	7.9	10.8	13.4
317	8.3	11.3	14.1
318	8.1	11.0	13.7
322	7.8	10.5	13.1

# ENGINEERING

## Axial Play

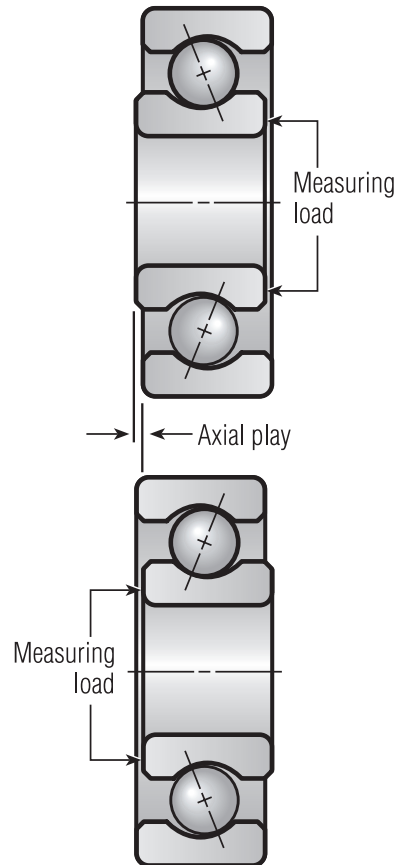
### Axial Play

Axial play, also called end play, is the maximum possible movement, parallel to the bearing axis, of the inner ring in relation to the outer ring. It is measured under a light reversing axial load.

End play is a function of radial internal clearance, thus the nominal end play values given in Table 13 and Table 14 are expressed for various radial play codes of deep groove instrument and spindle turbine bearings.

End play will increase when a thrust load is imposed, due to axial yield. If this is objectionable, the end play can be reduced by axial shimming or axial preloading.

End play is not a design specification; the Barden Product Engineering Department should be consulted if end play modifications are desired.



*Fig. 6. Axial play, or end play, is defined as the maximum possible movement, parallel to the axis of the bearing, of the inner ring relative to the outer ring.*

# ENGINEERING

## Axial Play

**Table 13. Nominal axial play values of deep groove miniature and instrument and thin section bearings.**

Basic Bearing Number	Radial Play Codes				
	2	3	4	5	6
SR0, SR133	.048	.058	.066	.084	.102
SR1, SR1-4, SR143, SR144, SR144X3, SR154X1, SR155, SR156, SR156X1, SR164, SR164X3, SR168, SR174X2, SR174X5, SR184X2, SR2X52	.053	.066	.074	.094	.114
SR1-5, SR2, SR2A, SR2-5, SR2-6, SR2-5, SR2-6, SR2-5X2, SR166, SR186X2, SR186X3, SR188, SR1204X1, SR1810	.066	.081	.094	.119	.145
SR3, SR3X8, SR3X23, SR4, SR4X35	.084	.102	.117	.147	.178
SR4A	.097	.122	.135	.183	.218
SR6	.107	.130	.150	.191	.229
SR8	.053	.064	.074	.094	.112
SR10	.053	.066	.076	.097	.117
S18M1-5, S19M1-5, S19M2-5	.048	.058	.066	.084	.102
S19M2, S38M2-5	.053	.066	.074	.094	.114
S38M3	.058	.071	.081	.104	.124
S2M3, S18M4, S38M4	.066	.081	.094	.119	.145
S2M4	.084	.102	.117	.147	.178
34, 34-5	.094	.117	.135	.170	.206
35, 36	.102	.124	.142	.180	.218
S18M7Y2	.076	.091	.107	.137	.163
37, 38	.107	.130	.150	.191	.231
37X2, 38X2, 38X6	.051	.061	.071	.091	.104
39	.053	.066	.076	.097	.114
A538 to A543	—	—	—	.094	.109
S538 to S543	—	—	—	.132	.155
SR1012, SR1216, SR1624	—	—	—	.112	.130

All dimensions in millimeters.

**Table 14. Nominal axial play values of deep groove spindle and turbine bearings.**

Basic Bearing Number	Radial Play Codes		
	3	5	6
100	.066	.097	.144
100X1	.102	.147	.178
101, 101X1	.081	.117	.142
102	.076	.112	.135
103	.066	.097	.114
104	.112	.157	.201
105	.094	.132	.170
106	.117	.165	.213
107	.130	.183	.234
108	.107	.173	.213
109, 110	.152	.201	.246
111	.183	.241	.292
200	.089	.124	.157
201, 201X1, 9201	.091	.130	.165
1902X1	.099	.145	.173
202, 202X1	.094	.132	.170
203, 9203	.097	.137	.175
204, 9204, 205, 9205	.107	.150	.191
206, 9206	.117	.191	.234
207, 9207	.124	.206	.254
208, 9208, 209, 9209	.130	.213	.262
210	.175	.231	.284
211	.208	.272	.333
213	.231	.302	.368
222	.356	.480	.594
232	.445	.615	.759
9302X1	.074	.109	.132
303	.104	.150	.183
305, 9305	.150	.188	.236
306	.155	.196	.244
307, 9307	.180	.246	.305
308, 9308	.180	.246	.305
309, 9309	.206	.272	.335
310, 9310	.216	.284	.351
311	.251	.328	.401
312, 9312	.259	.340	.417
313, 9313	.269	.353	.432
314, 9314	.287	.391	.457
316	.295	.404	.498
317	.330	.450	.556
318	.340	.462	.572
320	.536	.726	.902
322	.386	.518	.643

All dimensions in millimeters.

# ENGINEERING

## Ball Complement

Table 15. Deep groove instrument (inch) bearings.

Basic Bearing Number	Ball Complement	
	Number	Diameter
SR0	6	1/32"
SR133	7	1/32"
SR1	6	1mm
SR1-4, SR143, SR144, SR144X3, SR154X1	8	1mm
SR164X3, SR174X5, SR184X2, SR133W	8	1mm
SR155, SR156	9	1mm
SR2X52, SR174X2, SR156X1, SR168	11	1mm
SR1-5, SR2-5, SR2-5X2	6	1/16"
SR2-6, SR2, SR2A	7	1/16"
SR1204X1, SR166, SR186X2, SR186X3	8	1/16"
SR188, SR1810	11	1/16"
SR3, SR3X8, SR3X23	7	3/32"
SR4, SR4X35	8	3/32"
SR4A	6	9/64"
SR6	7	5/32"
SR8	10	5/32"
SR10	10	3/16"

Table 16. Deep groove flanged (inch) bearings.

Basic Bearing Number	Ball Complement	
	Number	Diameter
SFR0	6	1/32"
SFR133	7	1/32"
SFR1	6	1mm
SFR1-4, SFR144	8	1mm
SFR155, SFR156	9	1mm
SFR168	11	1mm
SFR1-5, SFR2-5	6	1/16"
SFR2-6, SFR2	7	1/16"
SFR166	8	1/16"
SFR188, SFR1810	11	1/16"
SFR3, SFR3X3	7	3/32"
SFR4	8	3/32"
SFR6	7	5/32"

Table 17. Deep groove instrument (metric) bearings.

Basic Bearing Number	Ball Complement	
	Number	Diameter
S18M1-5	6	1/32"
S19M2	8	1/32"
S19M1-5	7	1mm
S18M2-5, S38M2-5, S19M2-5	8	1mm
S38M3	7	3/64"
S2M3, S18M4, S38M4	7	1/16"
S19M5	11	1/16"
S18M7Y2	9	2mm
S2M4	7	3/32"
34, 34-5	6	1/8"
35, 36	6	9/64"
37, 37X2, 38, 38X2, 38X6	7	5/32"
39	7	3/16"

Table 18. Deep groove thin section (inch) bearings.

Basic Bearing Number	Ball Complement	
	Number	Diameter
SR1012ZA, SWR1012ZA	12	1/16"
SR1012TA, SWR1012TA	14	1/16"
SR1216ZA	15	1/16"
SR1216TA	17	1/16"
SR1420ZA	18	1/16"
SR1420TA	20	1/16"
SR1624ZA	21	1/16"
SR1624TA	23	1/16"
SN538ZA, A538ZA	9	1/8"
SN539ZA, A539ZA	11	1/8"
SN538TA, A538TA, A539T	12	1/8"
SN540ZA, A540ZA	13	1/8"
SN539TA, A540T	14	1/8"
SN541ZA, A541ZA	15	1/8"
SN540TA, A541ZA	16	1/8"
SN541TA, A542T	18	1/8"
SN542ZA, A542ZA	19	1/8"
SN542TA	20	1/8"
SN543ZA, SN543TA, A543ZA, A543T	22	1/8"

# ENGINEERING

## Ball Complement

Table 19. Deep groove Spindle and Turbine (metric) bearings.

Basic Bearing Number	Ball Complement	
	Number	Diameter
1902X1	11	$\frac{9}{64}''$
100, 100X1	7	$\frac{3}{16}''$
101, 101X1(T), 101X1(TMT)	8	$\frac{3}{16}''$
102	9	$\frac{3}{16}''$
103	10	$\frac{3}{16}''$
200	7	$\frac{7}{32}''$
201, 201X1, 9201	7	$\frac{15}{64}''$
202(T), 202(TMT), 202X1	7	$\frac{1}{4}''$
104	9	$\frac{1}{4}''$
105	10	$\frac{1}{4}''$
203(T), 203(TMT), 9203	8	$\frac{17}{64}''$
106	11	$\frac{9}{32}''$
9302X1	7	$\frac{5}{16}''$
204(T), 204(TMT), 9204(TMT), 205(T), 205(TMT), 9205(T) 9205(TMT)	8	$\frac{5}{16}''$
107	11	$\frac{5}{16}''$
108	12	$\frac{5}{16}''$
206(T), 206(TMT), 9206(T), 9206(TMT)	9	$\frac{3}{8}''$
110	13	$\frac{3}{8}''$
109	16	$\frac{3}{8}''$
9305	7	$\frac{7}{16}''$
207(T), 207(TMT), 9207(T), 9207(TMT)	9	$\frac{7}{16}''$
111	12	$\frac{7}{16}''$
208(T), 208(TMT), 9208(T), 9208(TMT)	9	$\frac{15}{32}''$
305, 209(T), 209(TMT), 9209(T), 9209(TMT)	10	$\frac{15}{32}''$
210	14	$\frac{1}{2}''$
9307(T), 9307(TMT)	7	$\frac{9}{16}''$
307(T), 307(TMT)	11	$\frac{9}{16}''$
211	14	$\frac{9}{16}''$
308, 9308	11	$\frac{5}{8}''$
9309	8	$\frac{11}{16}''$
309	11	$\frac{11}{16}''$
9310	8	$\frac{3}{4}''$
310	11	$\frac{3}{4}''$
311	8	$\frac{13}{16}''$
312, 9312	8	$\frac{7}{8}''$
313(T), 9313(T), 9313(TMT)	8	$\frac{15}{16}''$
314	8	1"
9314	8	1"
315, 316	8	$1\frac{1}{16}''$
317	8	$1\frac{1}{8}''$
222	10	$1\frac{1}{8}''$
318	8	$1\frac{3}{16}''$
320	8	$1\frac{3}{8}''$
232	11	$1\frac{3}{8}''$
322	8	$1\frac{1}{2}''$

Table 20. Angular contact (inch) bearings.

Basic Bearing Number	Ball Complement	
	Number	Diameter
R144H	8	1mm
R1-5B	6	$\frac{1}{16}''$
R1-5H, R2-5B, R2B, R2-6H	7	$\frac{1}{16}''$
R2H, R2-5H	8	$\frac{1}{16}''$
R3B	7	$\frac{3}{32}''$
R3H, R4B	8	$\frac{3}{32}''$
R4H	9	$\frac{3}{32}''$
R4HX8	8	$\frac{9}{64}''$
R8H	12	$\frac{5}{32}''$

# ENGINEERING

## Ball Complement

Table 21. Angular Contact (metric) bearings.

Basic Bearing Number	Ball Complement	
	Number	Diameter
2M3BY3	7	1/16"
19M5BY1	11	1/16"
34BX4, 34-5B	6	1/8"
34H, 34-5H	8	1/8"
36BX1	6	9/64"
36H	8	9/64"
38BX2	7	5/32"
37H, 38H	9	5/32"
1901H	11	5/32"
1902H	14	5/32"
39H, 100H	9	3/16"
101H, 101BX48, 102BJJX6	10	3/16"
102H, 102BX48	11	3/16"
103H, 103BX48	13	3/16"
200H	9	7/32"
1905H	16	7/32"
201H	9	15/64"
202H	10	1/4"
104H, 104BX48	11	1/4"
105H, 105BX48	13	1/4"
1907H	19	1/4"
301H	9	17/64"
203H	10	17/64"
106H, 106BX48	14	9/32"
204H	10	5/16"
205H	11	5/16"
107H, 107BX48	15	5/16"

Basic Bearing Number	Ball Complement	
	Number	Diameter
108H, 108BX48	17	5/16"
302H	9	11/32"
303H	10	11/32"
109H	16	3/8"
110H, 110BX48	18	3/8"
304H	9	13/32"
206H	11	13/32"
207H	12	7/16"
113BX48	18	7/16"
113H	19	7/16"
305H	10	15/32"
208H	12	15/32"
209H	13	15/32"
210H	14	1/2"
115H	20	1/2"
306H	10	17/32"
307H	11	9/16"
211H	14	9/16"
117BX48	20	9/16"
117H	21	9/16"
308H	11	5/8"
212H	14	5/8"
118H	19	5/8"
309H	11	11/16"
214H	15	11/16"
310H	11	3/4"
312H	12	7/8"
220H	15	1"

# ENGINEERING

## Preloading

Preloading is the removal of internal clearance in a bearing by applying a permanent thrust load to it. Preloading:

- Eliminates radial and axial play.
- Increases system rigidity.
- Reduces non-repetitive runout.
- Lessens the difference in contact angles between the balls and both inner and outer rings at very high speeds
- Prevents ball skidding under very high acceleration.

### Bearing Yield

Axial yield is the axial deflection between inner and outer rings after end play is removed and a working load or preload is applied. It results from elastic deformation of balls and raceways under thrust loading.

Radial yield, similarly, is the radial deflection caused by radial loading. Both types of yield are governed by the internal design of the bearing, the contact angle and load characteristics (magnitude and direction).

When a thrust load is applied to a bearing, the unloaded point-to-point contacts of balls and raceways broaden into elliptical contact areas as balls and raceways are stressed. All balls share this thrust load equally.

The radial yield of a loaded angular contact bearing is considerably less than the axial yield. Radial loading tends to force the balls on the loaded side of the bearing toward the bottom of both inner and outer raceways – a relatively small displacement. Thrust loading tends to make the balls climb the sides of both raceways with a wedging action. Combined with the contact angle, this causes greater displacement than under radial loading.

Zero load is the point at which only sufficient takeup has been applied to remove radial and axial play. Bearing yield is non-linear, resulting in diminishing yield rates as loads increase. This is because larger contact areas are developed between the balls and raceways.

If the high initial deflections are eliminated, further yield under applied external loads is reduced. This can be achieved by axial preloading of bearing pairs.

Not only are yields of preloaded pairs lower, but their yield rates are essentially constant over a substantial range of external loading, up to approximately three times the rigid

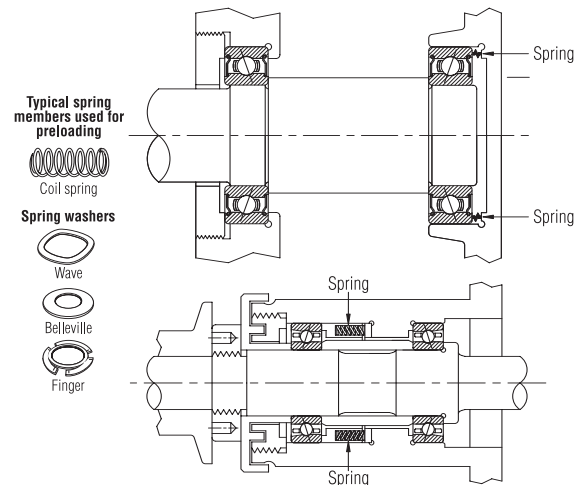
preload, at which point one of the bearings unloads completely.

Specific yield characteristics may be achieved by specifying matched preloaded pairs or by opposed mounting of two bearings. Consult Barden Product Engineering for yield rate information for individual cases.

### Preloading Techniques

Bearings should be preloaded as lightly as is necessary to achieve the desired results. This avoids excessive heat generation, which reduces speed capability and bearing life. There are three basic methods of preloading: springs, axial adjustment and duplex bearings.

**Fig. 7. Different types of spring preloading.**



### Spring Preloading

This is often the simplest method and should be considered first. Spring preloading provides a relatively constant preload because it is less sensitive to differential thermal expansion than rigid preloading and accommodates minor misalignment better. Also, it is possible to use bearings which have not been preload ground.

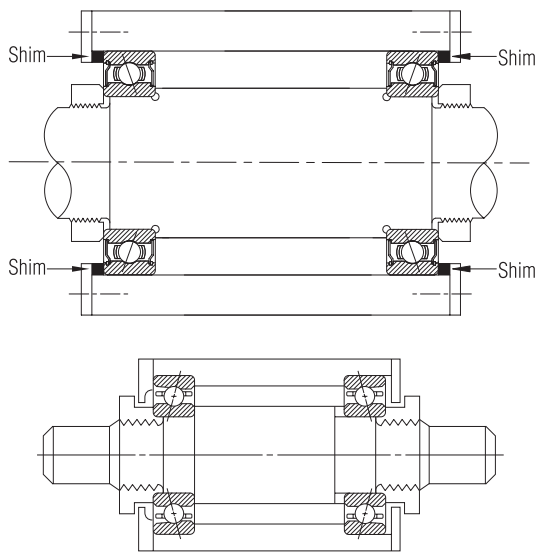
Many types of springs may be used (see Fig. 7), among them coil springs and Belleville, wave or finger spring washers. Usually the spring is applied to the nonrotating part of the bearing—typically the outer ring. This ring must have a slip fit in the housing at all temperatures.

# ENGINEERING

## Preloading

A disadvantage of this method is that spring preloading cannot accept reversing thrust loads. Space must also be provided to accommodate both the springs and spring travel, and springs may tend to misalign the ring being loaded.

**Fig. 8. Axial adjustment.**



### Axial Adjustment

Axial adjustment calls for mounting at least two bearings in opposition so that the inner and outer rings of each bearing are offset axially (see Fig. 8). Threaded members, shims and spacers are typical means of providing rigid preloads through axial adjustment.

This technique requires great care and accuracy to avoid excessive preloading, which might occur during setup by overloading the bearings, or during operation due to thermal expansion. Precision lapped shims are usually preferable to threaded members, because helical threads can lead to misalignment.

For low torque applications such as gyro gimbals, an ideal axial adjustment removes all play, both radial and axial, but puts no preload on either bearing under any operating condition.

The shims should be manufactured to parallelism tolerances equal to those of the bearings, because they must be capable of spacing the bearings to accuracies of

one to two micrometers or better. Bearing ring faces must be well aligned and solidly seated, and there must be extreme cleanliness during assembly.

### Duplex Bearings

Duplex bearings are matched pairs of bearings with built-in means of preloading. The inner or outer ring faces of these bearings have been selectively relieved a precise amount called the preload offset.

When the bearings are clamped together during installation, the offset faces meet, establishing a permanent preload in the bearing set. Duplex bearings are usually speed-limited due to heat generated by this rigid preload.

Duplexing is used to greatly increase radial and axial rigidity. Duplex bearings can withstand bi-directional thrust loads (DB and DF mounting) or heavy uni-directional thrust loads (DT mounting). Other advantages include their ease of assembly and minimum runout.

Some drawbacks of duplex bearings include:

- Increased torque
- Reduced speed capacity
- Sensitivity to differential thermal expansion
- Susceptibility to gross torque variations due to misalignment
- Poor adaptability to interference fitting

For a given Barden duplex pair, bore and O.D. are matched within 0.0025mm, therefore, duplex sets should not be separated or intermixed. High points of eccentricity are marked on both inner and outer rings. The high points should be aligned during assembly (inner to inner, outer to outer) to get a smoother, cooler and more accurate running spindle.

Most Barden deep groove and angular contact bearings are available in duplex sets. Deep groove bearings are usually furnished in specific DB, DF or DT configurations. Larger spindle and turbine angular contact bearings of Series 100, 200 and 300 are available with light, medium and heavy preloads (Table 24). Specific applications may require preload values that are non-standard. Please consult our Product Engineering department if you need help with preload selection.



# ENGINEERING

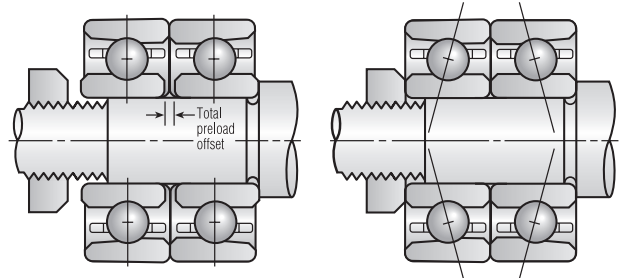
## Preloading

### DB mounting (back-to-back)

This configuration is suited for most applications having good alignment of bearing housings and shafts. It is also preferable where high moment rigidity is required, and where the shaft runs warmer than the housing.

Inner ring abutting faces of DB duplex bearings are relieved. When they are mounted and the inner rings clamped together, the load lines (lines through points of ball contact) converge outside the bearings, resulting in increased moment rigidity.

Fig. 9. DB mounting.

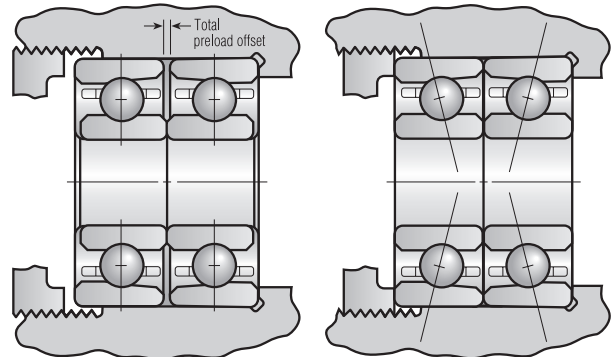


### DF mounting (face-to-face)

DF mounting is used in few applications – mainly where misalignment must be accommodated. Speed capability is usually lower than a DB pair of identical preload.

Outer ring abutting faces of DF duplex bearings are relieved. When the bearings are mounted and the outer rings clamped together, the load lines converge toward the bore.

Fig. 10. DF mounting.

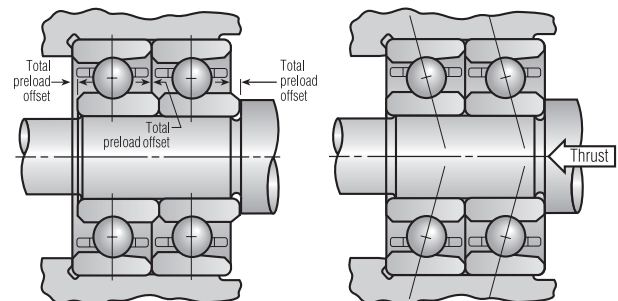


### DT mounting (tandem)

DT pairs offer greater capacity without increasing bearing size, through load sharing. They can counter heavy thrust loads from one direction, but they cannot take reversing loads as DB and DF pairs can. However, DT pairs are usually opposed by another DT pair or a single bearing.

Abutting faces of DT pairs have equal offsets, creating parallel load lines. When mounted and preloaded by thrust forces, both bearings share the load equally.

Fig. 11. DT mounting.



# ENGINEERING

## Preloading

### Duplex Bearing Spacers

All duplex pairs can be separated by equal width spacers to increase moment rigidity. Inner and outer ring spacer widths (axial length) must be matched to within .0025mm; their faces must be square with the bore and outside cylindrical surface, flat and parallel within .0025mm to preserve preload and alignment. Custom designed spacers can be supplied with bearings as a matched set.

Fig. 12. Duplex bearing pairs with equal width spacers.

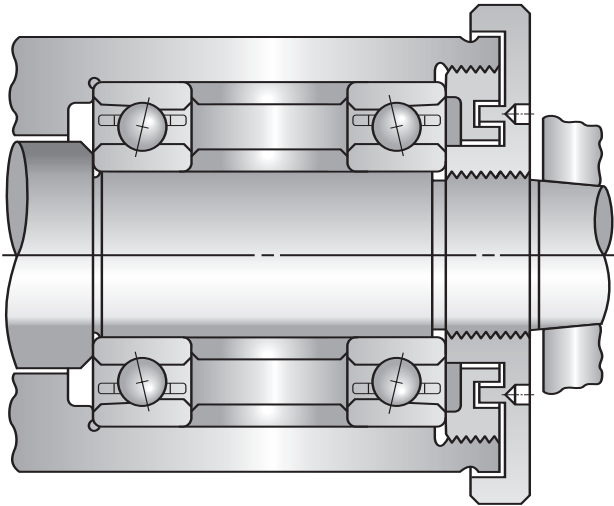


Table 22. Standard preloads (N) for Barden deep groove bearings: Series 100 and 200.

Bore Size	Series 100	Series 200
	M (Medium)	M (Medium)
10	44	53
12	44	62
15	58	76
17	80	98
20	89	133
25	111	156
30	156	222
35	178	311
40	200	378
45	311	400
50	334	489
55	400	645

Fig. 13. Increased stiffness can be achieved by mounting bearings in sets.

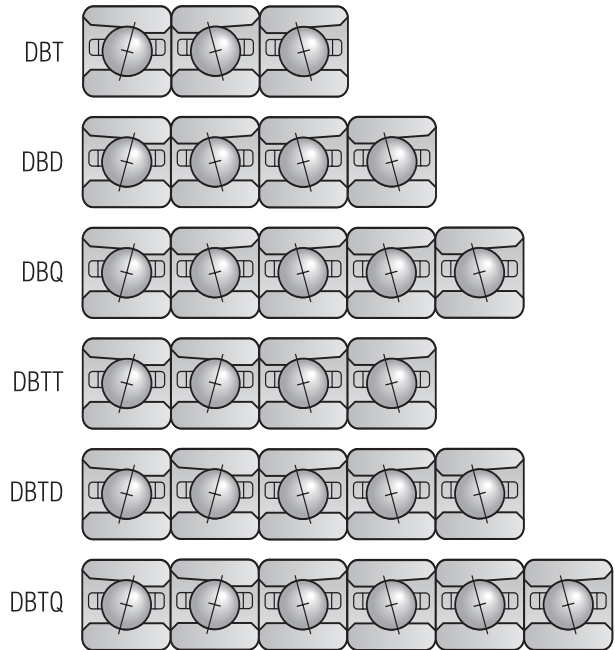


Table 23. Standard preloads (N) for Barden miniature and instrument angular contact bearings.

Basic Bearing Number	Bearing Nomenclature		Standard Preload (N)
	Separable B	Nonseparable H	
R1-5	R1-5B	R1-5H	4.5
R144	—	R144H	2.2
R2-5	R2-5B	R2-5H	9
R2	R2B	R2H	9
R2-6	—	R2-6H	9
R3	R3B	R3H	9
R4	R4B	R4H	9
R4HX8	—	R4HX8	27
R8	—	R8H	36
2M3BY3	2M3BY3	—	9
34	—	34H	27
34BX4	34BX4	—	27
34-5	34-5B	34-5H	27
19M5	19M5B	—	9
36BX1	36BX1	—	27
37	—	37H	53
38	—	38H	53
38BX2	38BX2	—	53
39	39H	—	67

# ENGINEERING

## Preloading

Table 24. Standard preloads (N) for Barden angular contact bearings: Series 100, 200 and 300.

Bore Size	Series 100 (H) (B) (J)			Series 200 (H) (B) (J)			Series 300 (H) (B) (J)		
	L (Light)	M (Medium)	H (Heavy)	L (Light)	M (Medium)	H (Heavy)	L (Light)	M (Medium)	H (Heavy)
10	18	44	89	27	67	133	44	111	222
12	22	53	107	31	76	156	44	111	222
15	22	58	116	36	89	178	53	133	267
17	27	67	133	44	111	222	89	200	400
20	44	111	222	67	156	311	89	245	489
25	53	133	267	67	178	356	133	356	712
30	67	178	356	111	289	578	178	445	890
35	89	222	445	133	356	712	222	556	1112
40	111	267	534	178	423	845	289	712	1423
45	133	356	712	178	445	890	334	845	1690
50	156	378	756	222	556	1112	400	1023	2046
55	222	534	1068	289	712	1423	489	1201	2402
60	222	578	1156	356	890	1779	578	1423	2847
65	222	578	1156	445	1112	2224	667	1646	3292
70	289	712	1423	445	1156	2313	756	1868	3736
75	311	756	1512	445	1156	2313	801	2046	4092
80	400	979	1957	534	1379	2758	934	2357	5160
85	400	1023	2046	667	1646	3292	1156	2936	5871
90	489	1245	2491	712	1779	3558	1156	2936	5871
95	534	1290	2580	845	2091	4181	1423	3558	7117
100	578	1379	2758	979	2402	4804	–	–	–
105	667	1601	3203	1023	2535	5071	–	–	–
110	667	1735	3469	1245	2980	5960	–	–	–
120	756	1868	3736	–	–	–	–	–	–
130	1023	2491	4982	–	–	–	–	–	–
140	1112	2578	5516	–	–	–	–	–	–
150	1245	3114	6227	–	–	–	–	–	–

Table 25. Standard preloads (N) for Barden Series 1900 angular contact bearings.

Bore Size	Series 1900 (H)		
	L (Light)	M (Medium)	H (Heavy)
12	18	40	80
15	18	44	89
25	36	89	178
35	53	133	267

# ENGINEERING

## Lubrication

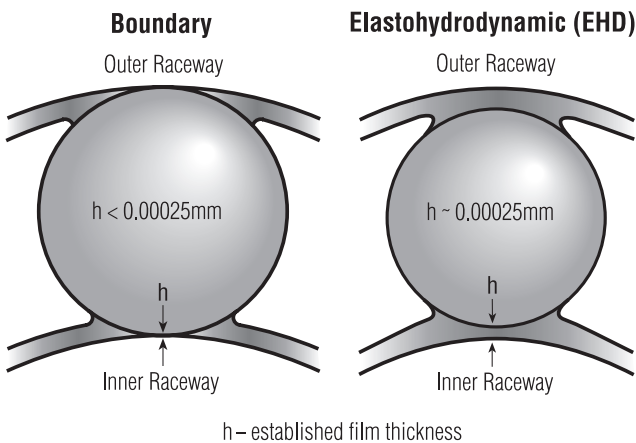
Adequate lubrication is essential to the successful performance of anti-friction bearings. Increased speeds, higher temperatures, improved accuracy and reliability requirements result in the need for closer attention to lubricant selection. Lubricant type and quantity have a marked effect on functional properties and service life of each application. Properly selected lubricants:

- Reduce friction by providing a viscous hydrodynamic film of sufficient strength to support the load and separate the balls from the raceways, preventing metal-to-metal contact.
- Minimise cage wear by reducing sliding friction in cage pockets and land surfaces.
- Prevent oxidation/corrosion of rolling elements.
- Act as a barrier to contaminants.
- Serve as a heat transfer agent in some cases, conducting heat away from the bearing.

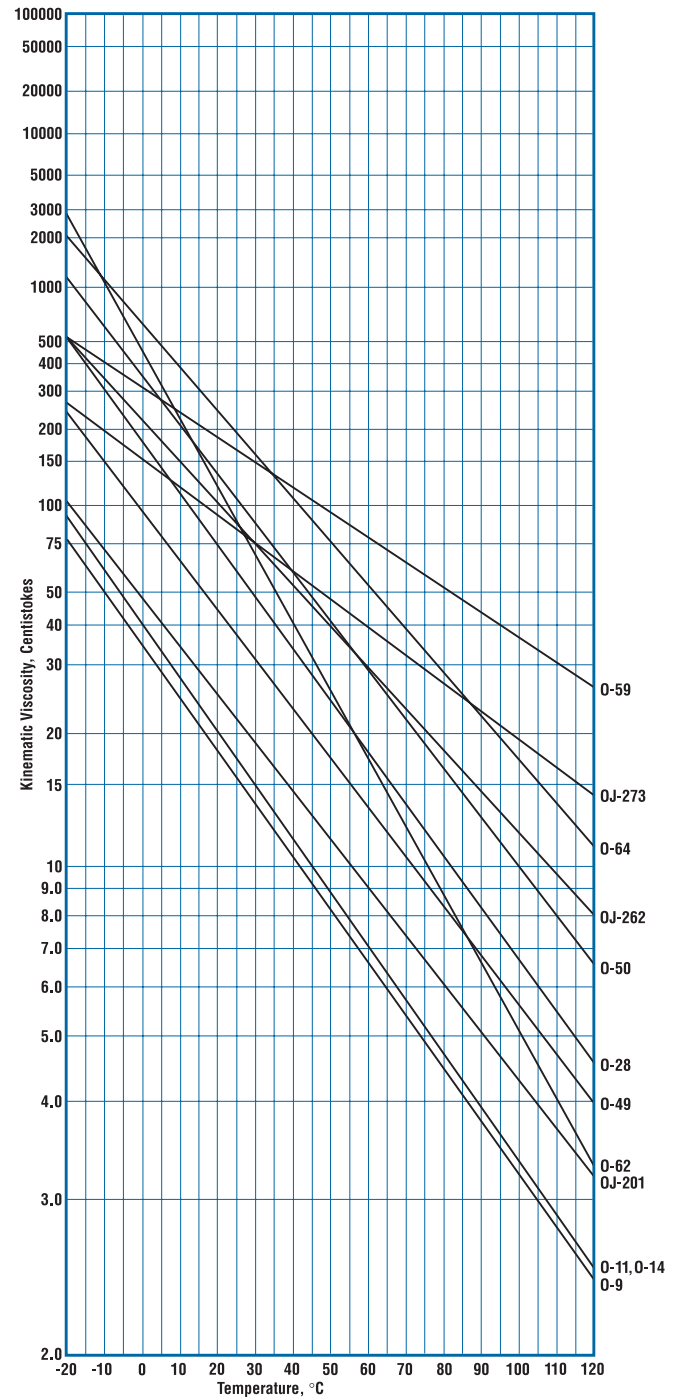
Lubricants are available in three basic forms:

- Fluid lubricants (oils).
- Greases – solid to semi-solid products consisting of an oil and a thickening agent.
- Dry lubricants, including films. Dry film lubrication is usually limited to moderate speed and very light loading conditions. For more information, see Surface Engineering section (pages 75–76).

Fig. 14. Lubrication regimes.

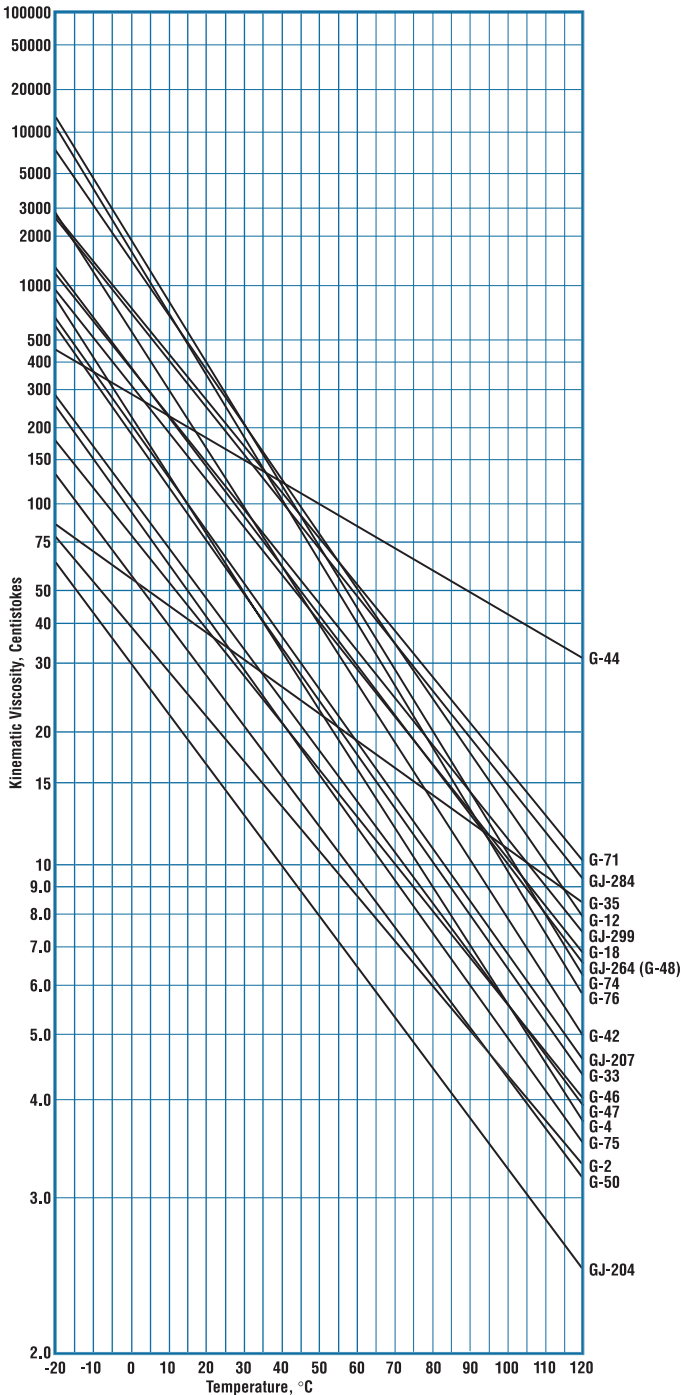


Viscosity graph for several typical oil lubricants.



## Lubrication

Viscosity graph for several typical grease lubricants.



### Barden Lubrication Practices

Factory pre-lubrication of bearings is highly recommended, since the correct quantity of applied lubricant can be as important as the correct type of lubricant. This is especially true of greases, where an excess can cause high torque, overheating and – if the speed is high enough – rapid bearing failure.

Based on its lengthy experience in this field, Barden has established standard quantities of lubricants that are suitable for most applications. When grease is specified, Barden applies a predetermined amount of filtered grease to the appropriate bearing surfaces.

Barden bearings normally available from stock are furnished with the following standard lubricants:

- Deep groove open bearings
  - Instrument sizes . . . . .O-11
  - Spindle and turbine sizes . . . . .O-9
- Deep groove shielded or sealed
  - Instrument sizes . . . . .G-2
  - Spindle and turbine sizes . . . . .G-74
- Angular contact bearings
  - Instrument sizes . . . . .O-11
  - Spindle and turbine sizes . . . . .O-9

### Lubricant Selection

Selection of lubricant and method of lubrication are generally governed by the operating conditions and limitations of the system. Three of the most significant factors in selecting a lubricant are:

- Viscosity of the lubricant at operating temperature.
- Maximum and minimum allowable operating temperatures.
- Operating speed.

Tables 26 and 27 (pages 103 and 104) provides comparative reference data, including temperature ranges and speed limits, for several of the lubricants used by Barden.

Hydrodynamic films are generated with both oils and greases, but do not exist in a true sense with dry films. The formation of an elastohydrodynamic film depends mainly on bearing speed and lubricant viscosity at

# ENGINEERING

## Lubrication

operating temperature. Computational methods for determining the effect of elastohydrodynamic films on bearing life are given on page 116 (calculating fatigue life).

The minimum viscosity required at operating temperature to achieve a full elastohydrodynamic film may be obtained from the following formula:

Instrument bearings (Series R, R100, R1000, FR, 500 and 30)

$$V = \frac{1800 \times 10^6}{nCN C_p}$$

Spindle and turbine bearings (Series 1900, 100, 200, 300 and 9000)

$$V = \frac{6700 \times 10^6}{nCN C_p}$$

where

V = Viscosity in centistokes at operating temperature

C = Basic load rating in Newtons

N = Speed in rpm

n = Number of balls (see pages 92–94)

C<sub>p</sub> = Load factor (see Figure 20, page 118)

### Grease Considerations

The primary advantage of grease over oil is that bearings can be prelubricated with grease, eliminating the need for an external lubrication system. This grease is often adequate for the service life of the application, especially in extra-wide Series 9000 bearings which have greater than usual grease capacity.

Besides simplicity, grease lubrication also requires less maintenance and has less stringent sealing requirements than oil systems. Grease tends to remain in proximity to bearing components, metering its oil content to operating surfaces as needed.

On the other hand, grease can be expected to increase the initial bearing torque and may exhibit a slightly higher running torque. Other considerations:

**Speedability.** This is expressed as a dN value, with dN being the bearing bore in mm multiplied by RPM. The greatest dN that greases can normally tolerate for continuous operation is approximately 1,200,000. Speed limits for greases are generally lower than for oils due to the plastic nature of grease that tends to cause overheating at high

speed. Compared to circulating oil, grease has less ability to remove heat from bearings.

**Temperature.** Most greases are limited to a maximum temperature of 176°C some only to 121°C or 93°C. Specially formulated high temperature greases can operate at 232°C or 260°C for short periods. For all greases, life is severely shortened by operation near their temperature limits.

**Consistency (stiffness).** Stiffer consistency greases are beneficial for applications with outer ring rotation where centrifugal force tends to sling grease out of the bearing, and those vertical axis applications (bearings installed horizontally) where gravity pulls grease away from its intended position.

Channeling type greases have the property of being displaced during initial running and maintaining a relatively fixed position during life. Other things being equal, high-speed torques with channeling greases will be lower. Non-channeling greases will tend to give high torque at low temperatures and high pumping losses at high temperatures.

**Bleeding.** Every grease has a tendency to “bleed” – that is, the oil component separates from its thickener. The amount of bleeding varies with the type of grease, its oil viscosity and thickener characteristics. This phenomenon requires consideration if there is a lengthy time before initial bearing usage or between periods of operation.

If bearings are installed in mechanisms which are used soon after assembly and are not subject to extended shutdowns, no problem is created.

**Combination of factors.** To maintain a normal grease life expectancy, adverse operating conditions must not be present in combination. Thus, at temperatures near the upper limit for a given grease, speed and load should be low. Or, at maximum speeds, temperature and load should be low.

In certain applications, such combinations are unavoidable and tradeoffs are necessary. For example, if speed and temperature are both high, loads must be low and life will be short.

**Grease thickeners.** There are several types of thickeners,

# ENGINEERING

## Lubrication

**Table 26. Typical oil lubricants recommended for use in Barden Precision Bearings.**

Barden Code	Designation	Base Oil	Operating Temperature Range °C	Maximum dN	Comments
0-9	Exxon instrument oil	Petroleum	-54 to 66	1,500,000*	Anti-oxidation, anti-corrosion E.P. additives.
0-11	Winsorlube L-245X	Diester	-54 to 66	1,500,000*	Attacks paint, neoprene, anti-corrosion additives. MIL-L-6085.
0-14	Exxon Turbo Oil #2389	Diester	-54 to 176	1,500,000*	Anti-oxidation, additives, MIL-L-7808.
0-28	SHF-61	Synthetic hydrocarbon	-54 to 176	1,500,000*	Good heat stability, low volatility.
0-49	Exxon Turbo Oil #2380	Diester	-54 to 176	1,500,000*	Anti-oxidation additives, MIL-L-23699.
0-50	NYE Synthetic 181B	Synthetic hydrocarbon	-40 to 150	1,500,000*	Good heat stability, low volatility.
0-59	Bray Micronic 815Z	Perfluorinated polyether	-73 to 260	400,000	Low surface tension, but does not migrate.
0-62	Du Pont Krytox 1506	Fluorocarbons	-51 to 288	400,000	Low surface tension, but does not migrate.
0-64	NYE Synthetic Oil 2001	Synthetic hydrocarbon	-46 to 127	400,000	Instrument, general purpose lubricant excellent for use in hard vacuum applications where very low out gas properties are desired
OJ-201	Aeroshell Fluid 12	Synthetic Ester	-54 to 150	1,500,000*	MIL-L-6085, Attacks paint, natural rubber, and neoprene. Contains anti-corrosion additives.
OJ-228	Nycolube 11B	Synthetic Ester	-54 to 150	1,500,000*	MIL-L-6085, Attacks paint, natural rubber, and neoprene. Contains anti-corrosion additives.
OJ-262	Anderol L465	Synthetic	-29 to 232	1,500,000*	Low out gas properties for wide temperature range. Contains anti-corrosion, and anti-oxidation additives. Contains anti-corrosion, anti-wear additives.
OJ-273	Nyosil M25	Silicone	-50 to 200	200,000	Low surface tension, tends to migrate.

\* Max dN for continuous oil supply.

each with its own special characteristics and advantages for specific applications. The most common types of thickeners used in precision bearing applications are:

- **Barium complex:** non-channeling, water resistant.
- **Sodium:** channeling type, water soluble, low torque.
- **Lithium:** non-channeling, offers good water resistance, generally soft.
- **Polyurea:** non-channeling, water resistant very quiet running.
- **Clay:** non-channeling, water resistant, can be noisy in miniature and instrument bearings.
- **Teflon:** non-channeling, water resistant, chemical inertness, non-flammable, excellent oxidative and thermal stability.

**Grease Quantity.** “If a little is good, more is better!” Not always true! Too much grease can cause ball skid, localized over-heating in the ball contact area, cage pocket wear, and rapid bearing failure under certain conditions of operation. Generally, for precision high speed applications, grease quantity in a bearing should be about 20% to 30%

full based on the free internal space in a specific bearing. This quantity may be modified to meet the requirements of the application regarding torque, life, and other specifics.

**Grease Filtering.** Greases for precision bearings are factory filtered to preclude loss of precision, noise generation, high torque, and premature failure in the application. There is no intermediate grease container following the filtering operation since the in-line filter injects the grease into the bearings immediately prior to bearing packaging.

Grease filter sizes range from about 10 to 40 microns depending on grease variables such as thickener and additive particle size.

### Oil Considerations

While grease lubrication is inherently simpler than lubrication with oil, there are applications where oil is the better choice.

# ENGINEERING

## Lubrication

**Table 27. Typical grease lubricants recommended for use in Barden Precision Bearings.**

Barden Code	Designation	Base Oil	Thickener	Operating Temperature Range °C	Maximum dN*	Comments
G-2	Exxon Beacon 325	Diester	Lithium	-54 to 121	400,000	Good anti-corrosion, low torque.
G-4	NYE Rheolube 757SSG	Petroleum	Sodium	-40 to 93	650,000	Anti-oxidation additives, machine tool spindle grease.
G-12	Chevron SR1-2	Petroleum	Polyurea	-29 to 150	400,000	General purpose, moderate speed, water resistant.
G-18	NYE Rheotemp 500	Ester and petroleum	Sodium	-46 to 176	500,000	For high temperature, high speed. Not water resistant.
G-33	Mobil 28	Synthetic hydrocarbon	Clay	-62 to 176	400,000	MIL-G-81322, DOD-G-24508, wide temperature range.
G-35	Du Pont Krytox 240 AB	Perfluoro-alkylpolyether	Tetrafluoro-ethylenetelomer	-40 to 232	400,000	Excellent thermal oxidative stability, does not creep, water resistant and chemically inert.
G-42	NYE Rheolube 350-SBG-2	Petroleum	Sodium/Calcium	-34 to 121	650,000	Spindle bearing grease for normal temperatures and maximum life at high speed.
G-44	Braycote 601	Perfluorinated Polyether	Tetrafluoro-ethylenetelomer	-73 to 260	400,000	Excellent thermal and oxidative stability, does not creep water resistant, chemically inert.
G-46	Kluber Isoflex NBU-15	Ester	Barium Complex	-40 to 121	700,000	Spindle bearing grease for maximum speeds, moderate loads.
G-47	Kluber Asonic GLY32	Ester/Synthetic Hydrocarbon	Lithium	-51 to 150	600,000	Quiet running spindle bearing grease for moderate speeds and loads.
G-50	Kluber Isoflex Super LDS 18	Ester/Mineral	Lithium	-51 to 121	850,000	Spindle bearing grease for maximum speed and moderate loads.
G-71	Rheolube 2000	Synthetic Hydrocarbon	Organic Gel	-46 to 127	400,000	Instrument, general purpose grease with good anti-corrosion, and anti-wear properties. Excellent for use in hard vacuum applications where very low outgassing properties are desired
G-74	Exxon Unirex N3	Petroleum	Lithium	-40 to 150	650,000	Spindle bearing grease for moderate speeds and loads. Low grease migration. Good resistance to water washout and corrosion.
G-75	Arcanol L-75	PAO/Ester	Polyurea	-51 to 121	1,200,000	Spindle bearing grease for maximum speeds, moderate loads. Requires shorter run-in time than G-46.
G-76	Nye Rheolube 374C	Synthetic Hydrocarbon	Lithium	-40 to 150	650,000	Instrument, general purpose grease for moderate speeds and loads. Stiff, channeling grease with good resistance to water washout and corrosion.
GJ-204	Aeroshell Grease No 7	Synthetic Ester (Diester)	Microgel	-73 to 149	400,000	MIL-G-23827, general purpose aircraft, and instrument grease for heavy loads.
GJ-207	Aeroshell Grease No 22	Synthetic Hydrocarbon	Microgel	-65 to 204	400,000	MIL-G-81322, wide temperature range. Good low temperature torque.
GJ-264/ G-48	Kluber Asonic GHY72	Ester Oil	Polyurea	-40 to 180	500,000	Quiet running grease for moderate speeds, and loads. Good resistance to water washout, and corrosion.
GJ-284	Kluber Asonic HQ 72-102	Ester Oil	Polyurea	-40 to 180	600,000	Quiet running grease for moderately high speeds, and loads. Good resistance to water washout, and corrosion.
GJ-299	Kluber Asonic Q74-73	Synthetic Hydrocarbon Oil, Esteroil	Synthetic Organic	-40 to 165	500,000	Quiet running grease for moderate speeds, and loads.

\* Values shown can be achieved under optimum conditions. Applications approaching these values should be reviewed by Barden Product Engineering.



# ENGINEERING

## Lubrication

Instrument bearings with extremely low values of starting and running torque need only a minimal, one-time lubrication. Each bearing receives just a few milligrams of oil – a single drop or less.

In high-speed spindle and turbine applications, oil is continuously supplied and provides cooling as well as lubrication.

**Speedability.** Limiting speeds shown in the product tables (front of catalogue) for oil-lubricated bearings assume the use of petroleum or diester-based oils. These limits are imposed by bearing size and cage design rather than by the lubricant. The lubricant by itself can accommodate 1,500,000 dN or higher

In the case of silicone-based oils, the maximum speed rating drops to 200,000 dN. Similarly, when computing life for bearings lubricated with silicone-based oils, the Basic Load Rating (C) should be reduced by two-thirds (C/3).

For long life at high speeds, the lubrication system should provide for retention, circulation, filtration and possibly cooling of the oil. On all applications where speeds approach the upper limits, Barden Product Engineering should be consulted for application review and recommendations.

### Oil Properties

Some of the key properties of oils include:

- **Viscosity.** Resistance to flow.
- **Viscosity Index.** Rating of viscosity changes at varying temperatures.
- **Lubricity.** Rating of sliding friction at boundary conditions\* of lubrication.
- **Pour Point.** Lowest temperature at which oil will flow.
- **Oxidation Resistance.** Rating an oil's resistance to oxidation caused by high temperatures, presence of oxygen and catalytic metals (especially copper).
- **Corrosion Resistance.** Rating an oil's ability to protect bearing from corrosion.
- **Flash Point.** Temperature at which an oil gives off flammable vapors.
- **Fire Point.** Temperature at which an oil burns if ignited.

\*Boundary lubrication exists when less than a full elastohydrodynamic film is formed with resulting metal to metal contact — ball to raceway wear.

### Oil Types

Oils used in bearings are of two general types – petroleum and synthetics – which are usually supplemented by additives to compensate for deficiencies or to provide special characteristics.

#### Petroleum Oils

Classified as naphthenic or paraffinic, depending on the crude oil source. Excellent general-purpose oils at normal temperatures (-40°C to 121°C). Additives are typically required to inhibit oxidation, corrosion, foaming and polymerisation, and to improve viscosity index.

#### Synthetic Oils

Synthetic oils include the following:

**Diesters.** Synthetic oils developed for applications requiring low torque at subzero starting temperatures and higher operating temperatures. General temperature range: -59°C to 176°C.

**Silicones.** Synthetic compounds with a relatively constant viscosity over their temperature range. Used for very cold starting and low torque applications. Generally undesirable for high loads and speeds. General temperature range: -73°C to 232°C. Maximum dN rating of 200,000.

**Fluorocarbons.** Synthetic oils for corrosive, reactive or high temperature (up to 288°C) environments. Insoluble in most solvents. Excellent oxidative stability, low volatility. They provide poor protection against bearing corrosion. Designed for specific temperature ranges with several products used to cover from -57°C to 288°C.

**Synthetic Hydrocarbons.** These are fluids which are chemically reacted to provide performance areas superior to petroleum and other synthetic oils. These oils are useable over a wider temperature range than petroleum oils. They are less volatile, more heat resistant and oxidation-stable at high temperatures and are more fluid at low temperatures. General temperature range: -62°C to 150°C.

# ENGINEERING

## Lubrication

### Oil Lubrication Systems

Oil-lubricated bearings usually requires a systems approach. The most common types of lubrication systems are:

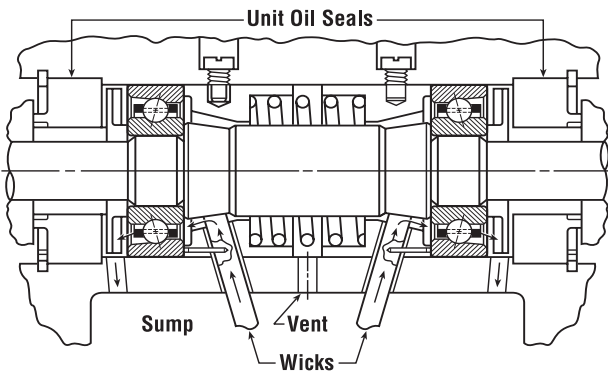
**Bath or Wick.** Oil is fed to the bearing from a built-in reservoir by wicking, dripping or submerging the bearing partially in oil.

**Splash.** From a built-in reservoir, oil is distributed by a high-speed rotating component partially submerged in oil.

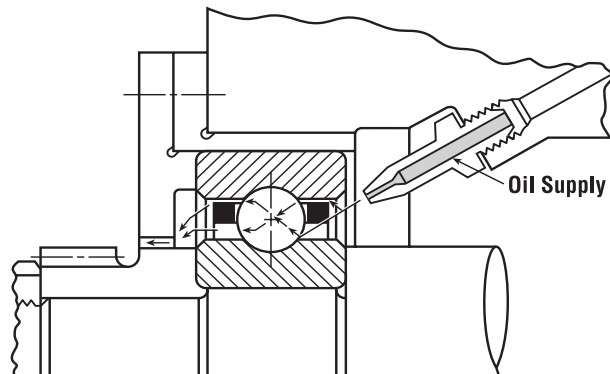
**Jet.** Oil is squirted into and through the bearing from an external source. Excellent where loads are heavy, speeds and temperatures are high. Efficiently applied flow of oil both lubricates and cools. Provision must be made to remove the oil after it passes through the bearing to prevent overheating.

For more information on lubrication windows/nozzle placement see Fig. 17 and 18.

**Fig. 15. Wick lubrication system.**

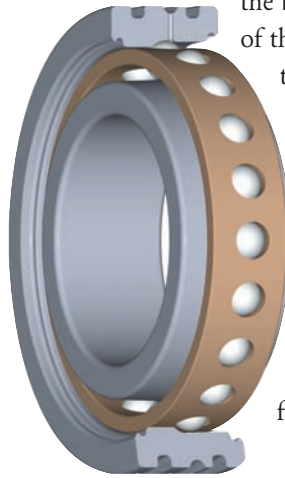


**Fig. 16. Jet lubrication system.**



### Bearings with Direct Lubrication

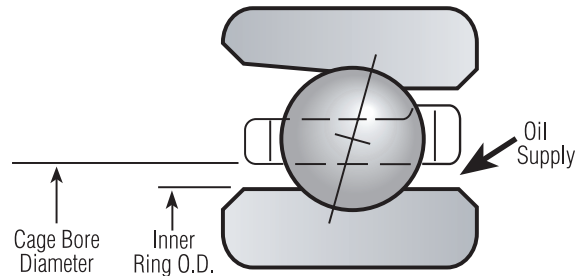
For high speed oil lubricated applications, many bearing types can be supplied with radial lubrication holes to take oil in close proximity to the ball to raceway contact zones from the bearing OD. The number and size of the lubricating holes can be varied to suit each application, and these holes are connected by a radial oil distribution groove. O rings on either side of the distribution groove prevent losses, ensuring the correct quantity of oil is delivered to the correct area. Please Contact Barden's Product Engineering Department for further details.



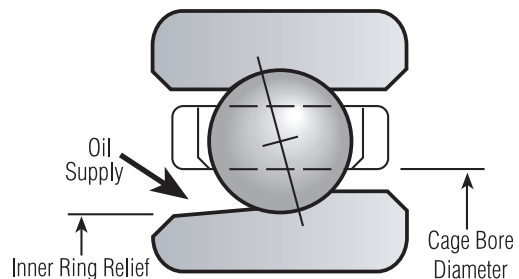
### Lubrication Windows

For those angular contact spindle bearings being lubricated by an air/oil or jet system the following tables will guide the placement of the spray or jet.

**Fig. 17. Lubrication window for H-type bearing.**



**Fig. 18. Lubrication window for B-type bearings.**



# ENGINEERING

## Lubrication

Table 28. Bearing lubrication window — 100H Series.

Bearing Size	Cage Bore Diameter (mm)	Inner Ring O.D. (mm)
100HJH	18.567	14.808
101HJH	20.447	15.418
102HJH	22.911	20.269
103HJH	25.959	22.733
104HJH	31.394	26.670
105HJH	35.306	32.791
106HJH	41.961	38.379
107HJH	47.422	44.526
108HJH	52.654	49.251
109HJH	58.674	55.220
110HJH	63.170	60.249
111HJH	70.587	66.142
112HJH	75.438	71.933
113HJH	80.188	76.276
114HJH	89.764	82.779
115HJH	93.142	88.646
116HJH	99.619	95.352
117HJH	104.242	100.330
118HJH	111.658	107.112
119HJH	116.332	112.065
120HJH	121.336	117.069
121HJH	128.448	123.749
122HJH	136.017	130.073
124HJH	145.440	140.081
126HJH	160.376	153.492
128HJH	169.672	163.500
130HJH	181.483	176.022

Table 29. Bearing lubrication window — 300H Series.

Bearing Size	Cage Bore Diameter (mm)	Inner Ring O.D. (mm)
304HJH	35.941	30.912
305HJH	43.282	37.490
306HJH	50.648	44.247
307HJH	57.277	50.368
308HJH	65.608	57.912
309HJH	72.263	63.754
310HJH	79.807	70.485

Table 30. Bearing lubrication window — 200H Series.

Bearing Size	Cage Bore Diameter (mm)	Inner Ring O.D. (mm)
200HJH	21.107	16.662
201HJH	23.292	18.313
202HJH	25.984	20.701
203HJH	28.473	25.044
204HJH	33.731	28.702
205HJH	38.506	33.528
206HJH	46.126	41.046
207HJH	53.746	47.168
208HJH	58.115	54.102
209HJH	64.491	58.141
210HJH	69.342	62.484
211HJH	76.403	70.206
212HJH	84.176	75.565
213HJH	91.008	83.693
214HJH	96.291	88.773
215HJH	100.838	93.777
216HJH	107.874	100.432
217HJH	115.316	107.569
218HJH	122.580	113.868
220HJH	137.185	127.305

Table 31. Bearing lubrication window — B Series.

Bearing Size	Cage Bore Diameter (mm)	Inner Ring O.D. (mm)
101BX48	17.780	15.469
102BX48	20.955	18.720
103BX48	23.241	21.260
104BX48	27.813	24.613
105BX48	32.537	29.616
106BX48	40.386	35.763
107BX48	44.450	39.853
108BX48	49.403	46.050
110BX48	60.706	55.448
113BX48	76.073	71.399
117BX48	100.432	93.167

# ENGINEERING

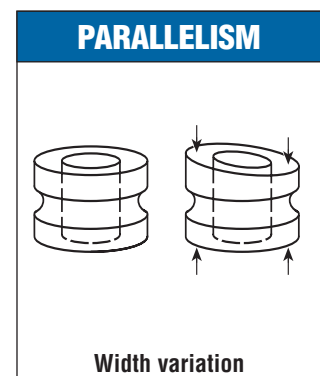
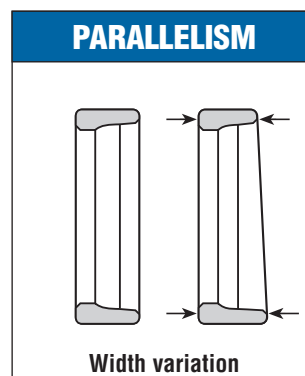
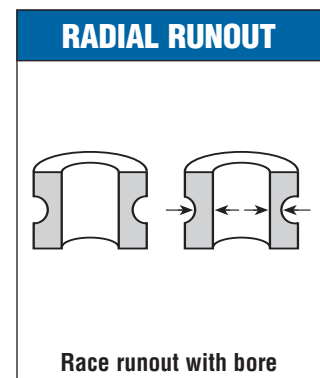
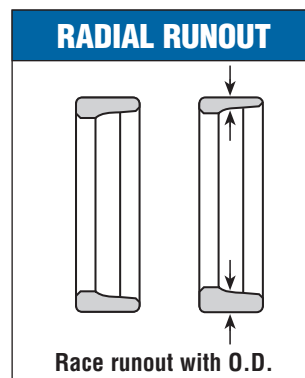
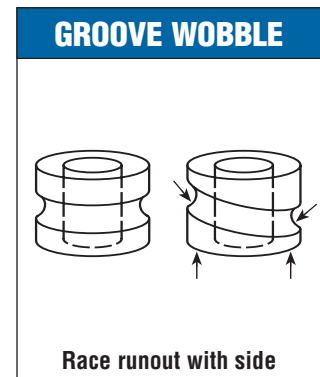
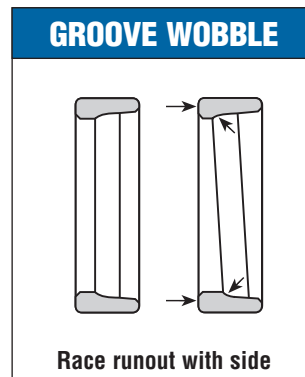
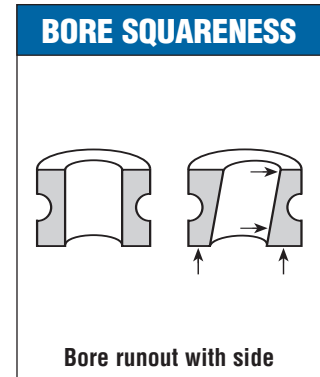
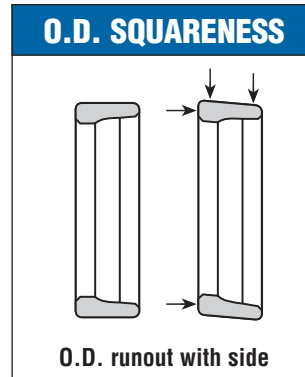
## Tolerances and Geometric Accuracy

### Tolerances & Geometric Accuracy

ABEC classes for precision ball bearings define tolerances for major bearing dimensions and characteristics divided into mounting dimensions and bearing geometry. The bearing geometry characteristics are illustrated at right.

In selecting a class of precision for a bearing application, the designer should consider three basic areas involving bearing installation and performance of the total mechanism:

1. How bearing bore and outside diameter variations affect:
  - a. Bearing fit with mating parts.
  - b. Installation methods, tools and fixtures necessary to install bearings without damage.
  - c. Radial internal clearance of mounted bearing.
  - d. Means of creating or adjusting preload.
  - e. Problems due to thermal changes during operation.
2. Allowable errors (runout) of bearing surfaces and:
  - a. Their relationship to similar errors in mating parts.
  - b. Their combined effect on torque or vibration.
3. Normally unspecified tolerances for the design, form or surface finish of both bearing parts and mating surfaces, which interact to affect bearing torque, bearing vibration and overall rigidity of the rotating mass.



# ENGINEERING

## Tolerances and Geometric Accuracy

### Exclusions From ABEC Standards

As useful as ABEC classes are for defining the levels of bearing precision, they are not all-inclusive. ABEC standards do not address many factors which affect performance and life, including:

- Materials
- Ball complement – number, size and precision
- Raceway curvature, roundness and finish
- Radial play or contact angle
- Cage design
- Cleanliness of manufacturing and assembly
- Lubricant

### Barden Internal Standards

Deep groove and angular contact instrument bearings are manufactured to ABEC 7P tolerances as defined by ABMA Standard 12.

Deep groove spindle and turbine size bearings are manufactured to ABEC 7 tolerances as defined by ABMA Standards 4 and 20 and ISO Standard 492.

Angular contact spindle and turbine size bearings are manufactured to ABEC 9 geometric tolerances. Mounting diameters (bore and OD) are measured and coded on every box. The tolerances conform to ABMA Standard 4 and 20 and ISO Standard 492.

To maintain a consistent level of precision in all aspects of its bearings, Barden applies internally developed standards to the important factors not controlled by ABEC.

Ball complement, shoulder heights, cage design and material quality are studied as part of the overall bearing design. Specialised component tolerances are used to check several aspects of inner and outer rings, including raceway roundness, cross race radius form and raceway finish.

The ABMA has generated grades of balls for bearings, but these are not specified in ABEC tolerance classes. Barden uses balls produced to its own specifications by Winsted Precision Ball Company, a wholly owned subsidiary of The Barden Corporation.

After its self-established criteria have been applied to bearing design and component manufacturing, Barden performs functional testing of assembled bearings to be sure they exhibit uniform, predictable performance characteristics.

### Special Tolerance Ranges

Barden can meet users' requirements for even tighter control of dimensions or functional characteristics than are specified in ABEC classifications. Working with customers, the Barden Product Engineering Department will set tolerances and performance levels to meet specific application needs.

### Low Radial Runout Bearings

Especially for high-precision spindles, Barden can provide bearings with a very tight specification on radial runout. This condition is designated by use of suffix "E" in the bearing number. Consult Barden Product Engineering for details.

# ENGINEERING

## Tolerance Tables

**Table 32. ABEC 7 Tolerances for Deep Groove Instrument (inch), Deep Groove Flanged (inch), Deep Groove Instrument (metric), Deep Groove Thin Section (inch) R1012 & 1216 (see Table 34 for R1420, R1624 & 500 series). All tolerances in mm.**

Inner Ring	ABEC Class 7P	ISO Class P4A (For reference only)
<b>Bore</b>		
Mean diameter (1)	+ .000 – 0.005	+ .000 – 0.005
Minimum diameter (4)	– .005	– .005
Maximum diameter (4)	0	0
Out of round maximum	.0025	.0025
Taper maximum	.0025	.0025
Radial runout maximum	.0025(5)	.0025(6)
Bore runout with sides maximum	.0025	.003
Raceway runout with sides maximum	.0025(5)	.003(6)
Width, single bearing individual rings	+ .000 – 0.025	+ .000 – 0.025
Width, duplex pair per pair (2)	+ .000 – 0.381	+ .000 – 0.200
Width variation maximum	.0025	.0025
Outer Ring	ABEC Class 7P	ISO Class P4 (For reference only)
<b>Open Bearings</b>		
Mean diameter (1)	+ .000 – .005	+ .000 – .005
Minimum diameter (4)	– .005	.005
Maximum diameter (4)	0	0
Out of round maximum	.0025	.0025
Taper maximum	.0025	.0025
<b>Bearings with closures</b>		
Mean diameter (1)	+ .000 – .005	+ .000 – .005
Minimum diameter (4)	– .006	– .006
Maximum diameter (4)	+ .001	+ .001
Out of round maximum	.0025	.0025
Taper maximum	.0025	.0025
Radial run out maximum (3)	.004(5)	.004(6)
Outside cylindrical surface run out with side maximum	.004	.004
Raceway run out with side maximum	.005(5)	.005(6)
Width, single bearing individual rings	+ .000 – .025	+ .000 – .025
Width, duplex pair per pair (2)	+ .000 – .381	+ .000 – .200
Width variation maximum	.0025	.0025
<b>Flanged Outer Rings</b>		
Diameter flange	+ .000 – .025	+ .000 – .025
Raceway run out with flange inside face maximum	.008	.008
Width flange	+ .000 – .050	+ .000 – .05
Width variation flange maximum	.0025	.0025

**Table 33. Tolerances for Deep Groove Thin Section (inch) A500 series. All tolerances in mm.**

Inner Ring	A538-A542	A543
<b>Bore</b>		
Mean diameter (1)	+ .000 – .0076	+ .0000 – .0076
Minimum diameter (4)	– .0076	– .0076
Maximum diameter (4)	0	0
Out of round — maximum	.005	.005
Taper — maximum	.005	.005
Radial run out — maximum (2)	.0038	.0038
Bore run out with side — maximum	.005	.0076
Raceway run out with side — maximum (2)	.005	.005
Width, single bearing — individual ring	+ .000 – .0025	+ .000 – .0025
Width, duplex pair — per pair (3)	+ .000 – .381	+ .000 – .381
Width variation — maximum	.0025	.0025
Outer Ring		
<b>Outside cylindrical surface</b>		
<b>Open Bearings</b>		
Mean diameter (1)	+ .0000 – .0102	+ .0000 – .0102
Minimum diameter (4)	– .0102	– .0102
Maximum diameter (4)	0	0
Out of round — maximum	.005	.005
Taper — maximum	.005	.005
<b>Bearings with closures</b>		
Mean diameter (1)	+ .0000 – .0102	+ .0000 – .0102
Minimum diameter (4)	– .0127	– .0152
Maximum diameter (4)	+ .0025	+ .005
Out of round — maximum	.005	.005
Taper — maximum	.005	.005
Radial runout — maximum (2)	.0038	.005
Outside cylindrical surface runout with side — maximum	.005	.005
Raceway runout with side — maximum (2)	.0076	.0102
Width, single bearing — individual ring	+ .0000 – .0254	+ .0000 – .0254
Width, duplex pair — per pair (3)	+ .000 – .381	+ .000 – .381
Width variation — maximum	.0025	.0025

(1) Mean diameter = 1/2 (maximum diameter + minimum diameter).

(2) Tolerances apply in component form and are approximately true in assembled bearing form (ANSI B3.4).

(3) If other than a pair of bearings, tolerance is proportional to number of bearings.

(4) All diameter measurements are two point measurements.

(1) Mean diameter = 1/2 (maximum diameter + minimum diameter).

(2) If other than a pair of bearings, tolerance is proportional to number of bearings.

(3) Radial run out of R10 outer ring is 0.0051.

(4) All diameter measurements are two point measurements.

(5) Tolerances apply in component form and are approximately true in assembled bearing.

(6) Tolerance applies to assembled bearing.



# ENGINEERING

## Tolerance Tables

**Table 34. Tolerances for Deep Groove Thin Section (inch) SN538 – SN543, R1420 – R1624 (See Table 32. for R1012 – R1216). All tolerances in mm.**

Inner Ring	Series R1000 Series 500 ABEC Class	R1420 SN538		R1624 SN539-541		SN542-543			
		5T	7T	5T	7T	5T	7T		
<b>Bore</b>									
Mean diameter, all series (1)		+ .0000 – .005	+ .0000 – .005	+ .0000 – .005	+ .0000 – .005	+ .0000 – .0076	+ .0000 – .005		
Minimum diameter, series R1000 (4)		– .0076	– .005	– .0102	– .0076	—	—		
Maximum diameter, series R1000 (4)		+ .0025	0	+ .0025	+ .0025	—	—		
Minimum diameter, series 500 (4)		– .0076	– .005	– .0076	– .0064	– .0102	– .0076		
Maximum diameter, series 500 (4)		+ .0025	0	+ .0025	+ .0013	+ .0025	+ .0025		
Radial runout — maximum (2)		.005	.0025	.005	.0038	.0076	.0038		
Bore runout with side — maximum		.0076	.0025	.0076	.0038	.0076	.0038		
Raceway runout with side — maximum (2)		.0076	.0025	.0076	.0038	.0076	.0038		
Width, single bearing — individual ring		+ .0000 – .0254	+ .0000 – .0254	+ .0000 – .0254	+ .0000 – .0254	+ .0000 – .0254	+ .0000 – .0254		
Width, duplex pair — per pair (3)		+ .0000 – .381	+ .0000 – .381	+ .0000 – .381	+ .0000 – .381	+ .0000 – .508	+ .0000 – .508		
Width variation — maximum		.005	.0025	.005	.0025	.005	.0025		
Outer Ring	Series R1000 Series 500 ABEC Class	R1420-R1624 SN538		SN539-541		SN542		SN543-544	
		5T	7T	5T	7T	5T	7T	5T	7T
<b>Outside cylindrical surface</b>									
<b>Open Bearings</b>									
Mean diameter, all series (1)		+ .0000 – .005	+ .0000 – .005	+ .0000 – .0104	+ .0000 – .005	+ .0000 – .0104	+ .0000 – .005	+ .0000 – .0104	+ .0000 – .0076
Minimum diameter, series R1000 (4)		– .0076	– .005	—	—	—	—	—	—
Maximum diameter, series R1000 (4)		+ .0025	0	—	—	—	—	—	—
Minimum diameter, series 500 (4)		– .0076	– .005	– .0127	– .0076	– .0127	– .0076	– .0127	– .0102
Maximum diameter, series 500 (4)		+ .0025	0	+ .0025	+ .0025	+ .0025	+ .0025	+ .0025	+ .0025
<b>Bearings with Closures</b>									
Mean diameter, all series (1)		+ .0000 – .005	+ .0000 – .005	+ .0000 – .0102	+ .0000 – .005	+ .0000 – .0102	+ .0000 – .005	+ .0000 – .0102	+ .0000 – .0076
Minimum diameter, series R1000 (4)		– .0102	– .0076	—	—	—	—	—	—
Maximum diameter, series R1000 (4)		+ .005	+ .0025	—	—	—	—	—	—
Minimum diameter, series 500 (4)		– .0102	– .0076	– .0152	– .0102	– .0152	– .0102	– .0152	– .0127
Maximum diameter, series 500 (4)		+ .005	+ .0025	+ .005	+ .005	+ .005	+ .005	+ .005	+ .005
Radial runout — maximum (2)		.005	.0038	.0076	.005	.0076	.005	.0076	.005
Outside cylindrical surface runout with side — maximum		.0076	.0038	.0076	.0038	.0076	.0038	.0076	.0038
Raceway runout with side — maximum (2)		.0076	.005	.0076	.005	.0076	.005	.0102	.0076
Width, single bearing — individual ring		+ .0000 – .0254	+ .0000 – .0254	+ .0000 – .0254	+ .0000 – .0254	+ .0000 – .1270	+ .0000 – .0254	+ .0000 – .1270	+ .0000 – .0254
Width, duplex pairs — per pair (3)		+ .0000 – .3810	+ .0000 – .3810	+ .0000 – .3810	+ .0000 – .3810	+ .0000 – .5080	+ .0000 – .5080	+ .0000 – .5080	+ .0000 – .5080
Width variation — maximum		.005	.0025	.005	.0025	.005	.0025	.005	.0038

(1) Mean diameter = 1/2 (maximum diameter + minimum diameter).

(2) Tolerances apply in component form and are approximately true in assembled bearing form (ANSI B3.4).

(3) If other than a pair of bearings, tolerance is proportional to number of bearings.

(4) All diameter measurements are two point measurements.

# ENGINEERING

## Tolerance Tables

**Table 35. Tolerances for Deep Groove Spindle Turbine bearings series 1900, 100, 200, 300 and 9000. All tolerances in mm.**

ABEC Class 7 Nominal bearing bore—mm	10	11-18	19-30	31-50	51-80	81-120	121-180
<b>Bore</b>							
Mean diameter (1)	+ .0000 – .0038(5)	+ .0000 – .0038	+ .0000 – .005	+ .0000 – .0064	+ .0000 – .0076	+ .0000 – .0076	+ .0000 – .0102
Minimum diameter (3)	– .0038(5)	– .0038	– .0038	– .005	– .005	– .0076	– .0089
Maximum diameter (3)	+ .0000	+ .0000	+ .0000	+ .0000	+ .0000	+ .0013	+ .0013
<b>Radial runout — maximum (4)</b>	.0025	.0025	.0025	.0038	.0038	.005	.0064
<b>Bore runout with side — maximum</b>	.0025	.0025	.0038	.0038	.005	.005	.0064
<b>Raceway runout with side — maximum (4)</b>	.0025	.0025	.0038	.0038	.005	.005	.0076
<b>Width, single bearing — individual ring</b>	+ .0000 – .0406	+ .0000 – .0813	+ .0000 – .1270	+ .0000 – .1270	+ .0000 – .1524	+ .0000 – .2032	+ .0000 – .2540
<b>Width, duplex pair — per pair (2)</b>	+ .0000 – .254	+ .0000 – .254	+ .0000 – .254	+ .0000 – .254	+ .0000 – .254	+ .0000 – .381	+ .0000 – .381
<b>Width variation — maximum</b>	.0025	.0025	.0025	.0025	.0038	.0038	.005
Nominal bearing Outer Ring O.D.—mm	26-30	31-50	51-80	81-120	121-150	151-180	181-250
<b>Outside cylindrical surface</b>							
<b>Open Bearings</b>							
Mean diameter (1)	+ .0000 – .005	+ .0000 – .0064	+ .0000 – .0076	+ .0000 – .0076	+ .0000 – .0089	+ .0000 – .0102	+ .0000 – .0114
Minimum diameter (3)	– .005	– .005	– .005	– .0089	.0089	– .0102	– .0102
Maximum diameter (3)	.0000	.0000	.0000	.0000	.0000	.0000	.0000
<b>Bearings with Closures</b>							
Mean diameter (1)	+ .0000 – .005	+ .0000 – .005	+ .0000 – .005	+ .0000 – .0076	+ .0000 – .00035	+ .0000 – .0102	+ .0000 – .0102
Minimum diameter (3)	– .0076	– .0102	– .0102	– .0152	– .0178	– .0178	– .0203
Maximum diameter (3)	+ .0025	+ .005	+ .005	+ .0076	+ .0076	+ .0076	+ .0102
<b>Radial runout — maximum (4)</b>	.0038	.005	.005	.0064	.0076	.0076	.0102
<b>Outside cylindrical surface runout with side — maximum</b>	.0038	.0038	.0038	.005	.005	.005	.0076
<b>Raceway runout with side — maximum (4)</b>	.005	.005	.005	.0064	.0076	.0076	.0102
<b>Width, single bearing — individual ring</b>	Same as Inner Ring						
<b>Width, duplex pair — per pair (2)</b>	Same as Inner Ring						
<b>Width variation — maximum</b>	.0025	.0025	.0025	.0038	.005	.005	.0076

(1) Mean diameter = 1/2 (maximum diameter + minimum diameter).  
 (2) If other than a pair of bearings, tolerance is proportional to number of bearings.  
 (3) All diameter measurements are two point measurements.  
 (4) Tolerances apply in component form and are approximately true in assembled bearing form (ANSI B3.4).



# ENGINEERING

## Tolerance Tables

**Table 36. Tolerances for Angular Contact inch and metric bearings Series 1900, 100, 200 & 300.**  
All tolerances in mm.

Inner Ring	Nominal bearing bore—mm	10	11-18	19-30	31-50	51-80	81-120
<b>Bore</b>							
Mean diameter (1)		+ .0000 – .0038	+ .0000 – .0381	+ .0000 – .005	+ .0000 – .0064	+ .0000 – .0076	+ .0000 – .0076
Minimum diameter (3)		– .0038	– .0381	– .005	– .0064	– .0076	– .0089
Maximum diameter (3)		+ .0000	+ .0000	+ .0000	+ .0000	+ .0000	+ .0013
Radial runout — maximum (4)		– .0013	.0013	.0025	.0025	.0025	.0025
Bore runout with side — maximum		– .0013	.0013	.0013	.0013	.0013	.0025
Raceway runout with side — maximum (4)		– .0013	.0013	.0025	.0025	.0013	.0025
Width, single bearing — individual ring		+ .0000 – .0406	+ .0000 – .0813	+ .0000 – .1270	+ .0000 – .1270	+ .0000 – .1524	+ .0000 – .2032
Width, duplex pair — per pair (2)		+ .0000 – .254	+ .0000 – .254	+ .0000 – .254	+ .0000 – .254	+ .0000 – .254	+ .0000 – .381
Width variation — maximum		– .0013	.0013	.0013	.0013	.0013	.0025
Outer Ring	Nominal bearing O.D.—mm	18-30	31-50	51-80	81-120	121-150	151-180
<b>Outside cylindrical surface</b>							
<b>Open Bearings</b>							
Mean diameter (1)		+ .0000 – .005	+ .0000 – .0064	+ .0000 – .0076	+ .0000 – .0076	+ .0000 – .0089	+ .0000 – .0102
Minimum diameter (3)		– .005	– .0064	– .0076	– .0076	.0089	– .0102
Maximum diameter (3)		.0000	.0000	.0000	.0000	.0000	.0000
Radial runout — maximum (4)		.0025	.0025	.0038	.005	.005	.005
Outside cylindrical surface runout with side — maximum		.0013	.0013	.0013	.0025	.0025	.0025
Raceway runout with side — maximum (4)		.0025	.0025	.0038	.005	.005	.005
Width, single bearing — individual ring		Same as Inner Ring					
Width, duplex pair — per pair (2)		Same as Inner Ring					
Width variation — maximum		.0013	.0013	.0013	.0025	.0025	.0025

(1) Mean diameter = 1/2 (maximum diameter + minimum diameter).

(2) If other than a pair of bearings, tolerance is proportional to number of bearings.

(3) All diameter measurements are two point measurements.

(4) Tolerances apply in component form and are approximately true in assembled bearing form (ANSI B3.4).

(5) 100, 200, 300 series have minimum bore tolerance of 0.0038".

# ENGINEERING

## Bearing Performance

### Bearing Life

The useful life of a ball bearing has historically been considered to be limited by the onset of fatigue or spalling of the raceways and balls, assuming that the bearing was properly selected and mounted, effectively lubricated and protected against contaminants.

This basic concept is still valid, but refinements have been introduced as a result of intensive study of bearing failure modes. Useful bearing life may be limited by reasons other than the onset of fatigue.

### Service Life

When a bearing no longer fulfills minimum performance requirements in such categories as torque, vibration or elastic yield, its service life may be effectively ended.

If the bearing remains in operation, its performance is likely to decline for some time before fatigue spalling takes place. In such circumstances, bearing performance is properly used as the governing factor in determining bearing life.

Lubrication can be an important factor influencing service life. Many bearings are prelubricated by the bearing manufacturer with an appropriate quantity of lubricant. They will reach the end of their useful life when the lubricant either migrates away from the bearing parts, oxidizes or suffers some other degradation. At that point, the lubricant is no longer effective and surface distress of the operating surfaces, rather than fatigue, is the cause of failure. Bearing life is thus very dependent upon characteristics of specific lubricants, operating temperature and atmospheric environment.

Specific determination of bearing life under unfavorable conditions can be difficult, but experience offers the following guidelines to achieve better life.

1. Reduce load. Particularly minimise applied axial preload.
2. Decrease speed to reduce the duty upon the lubricant and reduce churning.
3. Lower the temperature. This is important if lubricants are adversely affected by oxidation, which is accelerated at high temperatures.
4. Increase lubricant supply by improving reservoir provisions.
5. Increase viscosity of the lubricant, but not to the point where the bearing torque is adversely affected.
6. To reduce introduction of contaminants, substitute sealed or shielded bearings for open bearings and use extra care in installation.
7. Improve alignment and fitting practice, both of which will reduce duty on the lubricant and tend to minimise wear of bearing cages.

The most reliable bearing service life predictions are those based on field experience under comparable operating and environmental conditions.

### Bearing Capacity

Three different capacity values are listed in the product section for each ball bearing. They are:

- C – Basic dynamic load rating.
- $C_O$  – Static radial capacity.
- $T_O$  – Static thrust capacity.

# ENGINEERING

## Bearing Performance

All of these values are dependent upon the number and size of balls, contact angle, cross race curvature and material.

Basic dynamic load rating,  $C$ , is based on fatigue capacity of the bearing components. The word dynamic denotes rotation of the inner ring while a stationary radial load is applied. The  $C$  value is used to calculate bearing fatigue life in the equation:

$$L_{10} = \left(\frac{C}{P}\right)^3 \times 10^6 \text{ revolutions.}$$

$L_{10}$  = Minimum fatigue life in revolutions for 90% of a typical group of apparently identical bearings.

$P$  = Equivalent radial load.

Static radial capacity is based on ball-to-race contact stress developed by a radial load with both bearing races stationary. The static radial capacity,  $C_0$  of instrument bearings is the maximum radial load that can be imposed on a bearing without changing its performance characteristics, torque or vibration. It is based upon calculated stress values, assuming a maximum contact stress of 3.5 GPa (508,000 psi).  $C_0$  values for spindle and turbine bearings are based on a maximum contact stress of 4.2 GPa (609,000 psi).

Static thrust capacity,  $T_0$ , is rated similarly to  $C_0$ , with thrust loading developing the stress. The same mean and maximum stress levels apply.

In both radial and thrust loading, the stress developed between ball and raceway causes the point of contact to assume an elliptical shape. Theoretically, this contact ellipse should be contained within the solid raceway. Thus, thrust capacity is ordinarily a function of either the maximum allowable stress or the maximum force that generates a contact ellipse whose periphery just reaches the raceway edge. However, for lightly loaded, shallow raceway bearings, the maximum load may be reached at very low stress levels. Testing has shown that, for such bearings, a minor extension of the contact ellipse past the raceway edge may be allowed without a loss in bearing performance.

During the bearing selection process, there may be several candidate bearings which meet all design requirements but vary in capacity. As a general rule, the bearing with the highest capacity will have the longest service life.

# ENGINEERING

## Bearing Performance

### Fatigue Life

The traditional concept that bearing life is limited by the onset of fatigue is generally accurate for bearings operating under high stress levels. Recent test data confirms that, below certain stress levels, fatigue life with modern clean steels can be effectively infinite. However, since many factors affect practical bearing life, Barden Product Engineering will be pleased to review applications where theoretical life appears to be inadequate. The traditional basic relationship between bearing capacity imposed loading and fatigue life is presented here.

$$L_{10} = \left(\frac{C}{P}\right)^3 \times 10^6 \text{ revolutions.}^* \quad (\text{Formula 1})$$

In the above expression:

$L_{10}$  = Minimum life in revolutions for 90% of a typical group of apparently identical bearings.

C = Basic Dynamic Load Rating\*\*

P = Equivalent Radial Load, computed as follows:

$$P = XR + YT \quad (\text{Formula 2})$$

or

$$P = R \quad (\text{Formula 2})$$

whichever is greater.

In the preceding equation:

R = Radial load.

T = Thrust load.

X = Radial load factor relating to contact angle.

Y = Axial load factor depending upon contact angle, T and ball complement.

For Basic Load Ratings, see product section tables. For X and Y factors, see Tables 37 and 38.

**Table 37. Load factors for instrument bearings.**

T/nd <sup>2</sup>	Contact Angle, degrees			
	5	10	15	20
	Values of Axial Load Factor Y			
100	3.30	2.25	1.60	1.18
200	2.82	2.11	1.56	1.18
400	2.46	1.95	1.52	1.18
600	2.26	1.85	1.47	1.18
800	2.14	1.78	1.44	1.18
1200	1.96	1.68	1.39	1.18
2000	1.75	1.55	1.32	1.18
3000	1.59	1.45	1.27	1.18
4500	1.42	1.34	1.21	1.18
Values of Radial Load Factor X				
	0.56	0.46	0.44	0.43

**Table 38. Load factors for spindle and turbine bearings.**

T/nd <sup>2</sup>	Contact Angle, degrees				
	5	10	15	20	25
	Values of Axial Load Factor Y				
50	—	2.10	1.55	1.00	0.87
100	2.35	1.90	1.49	1.00	0.87
150	2.16	1.80	1.45	1.00	0.87
200	2.03	1.73	1.41	1.00	0.87
250	1.94	1.67	1.38	1.00	0.87
300	1.86	1.62	1.36	1.00	0.87
350	1.80	1.58	1.34	1.00	0.87
400	1.75	1.55	1.31	1.00	0.87
450	1.70	1.52	1.30	1.00	0.87
500	1.67	1.49	1.28	1.00	0.87
750	1.50	1.38	1.21	1.00	0.87
1000	1.41	1.31	1.17	1.00	0.87
1500	1.27	1.20	1.10	1.00	0.87
2000	1.18	1.13	1.05	1.00	0.87
2500	1.12	1.06	1.00	1.00	0.87
3000	1.07	1.02	1.00	1.00	0.87
3500	1.03	1.00	1.00	1.00	0.87
4000	1.00	1.00	1.00	1.00	0.87
4500	1.00	1.00	1.00	1.00	0.87
Values of Radial Load Factor X					
	0.56	0.46	0.44	0.43	0.41

Note: Values of nd<sup>2</sup> are found in the product section.

\*See ABMA Standard 9 for more complete discussion of bearing life in terms of usual industry concepts.

\*\*For hybrid (ceramic ball) bearings, Basic Load Ratings and static capacities should be reduced by 30% to reflect the lower ball yield characteristic compared to the raceways. In practise the real benefits of hybrid bearings occur in the non-optimum operational conditions where fatigue life calculations are not applicable (see pages 72-74).

# ENGINEERING

## Bearing Performance

Modifications to Formula 1 have been made, based on a better understanding of the causes of fatigue. Influencing factors include:

- An increased interest in reliability factors for survival rates greater than 90%.
- Improved raw materials and manufacturing processes for ball bearing rings and balls.
- The beneficial effects of elastohydrodynamic lubricant films.

Formula 1 can be rewritten to reflect these influencing factors as:

$$L_{10} \text{ Modified} = (A_1) (A_2) (A_3) \frac{16,666}{N} \left(\frac{C}{P}\right)^3 \text{ hours.} \quad (\text{Formula 3})$$

wherein:

$L_{10}$  = Number of hours which 90% of a typical group of apparently identical bearings will survive.

$N$  = Speed in rpm.

$A_1$  = Statistical life reliability factor for a chosen survival rate, from Table 39.

$A_2$  = Life modifying factor reflecting bearing material type and condition, from Table 40.

$A_3$  = Application factor, commonly limited to the elastohydrodynamic lubricant film factor calculated from formula 4 or 5. If good lubrication is assumed,  $A_3 = 3$ .

**Factor  $A_1$ .** Reliability factors listed in Table 39 represent a statistical approach. In addition, there are published analyses that suggest fatigue failures do not occur prior to the life obtained using an  $A_1$  factor of .05.

**Table 39. Reliability factor  $A_1$  for various survival rates.**

Survival Rate (Percentage)	Bearing Life Notation	Reliability Factor $A_1$
90	$L_{10}$	1.00
95	$L_5$	0.62
96	$L_4$	0.53
97	$L_3$	0.44
98	$L_2$	0.33
99	$L_1$	0.21

**Factor  $A_2$ .** While not formally recognized by the ABMA, estimated  $A_2$  factors are commonly used as represented by the values in Table 40. The main considerations in establishing  $A_2$  values are the material type, melting procedure, mechanical working and grain orientation, and hardness.

Note: SAE 52100 material in Barden bearings is vacuum processed, AISI 440C is air melted or vacuum melted – contact Barden Product Engineering for details.

**Table 40. Life modifying factor  $A_2$ .**

Process \ Material	440C	52100	M50	Cronidur 30
Air melt	.25X	NA	NA	NA
Vacuum processed	NA	1.0	NA	NA
VAR (CEVM)	1.25X	1.5X	NA	NA
VIM – VAR	1.5X	1.75X	2.0X	NA
PESR	NA	NA	NA	4.0X*

\*Cronidur 30 steel is only used in conjunction with ceramic balls.

**Factor  $A_3$ .** This factor for lubricant film effects is separately calculated for miniature and instrument (M&I) bearings and spindle and turbine (S&T) bearings as:

$$(\text{M\&I}) A_3 = 4.0 \times 10^{-10} n C N U C_p \quad (\text{Formula 4})$$

$$(\text{S\&T}) A_3 = 8.27 \times 10^{-11} n C N U C_p \quad (\text{Formula 5})$$

(The difference in constants is primarily due to the different surface finishes of the two bearing types.)

$U$  = Lubrication Factor (from Figure 19, page 118)

$n$  = number of balls (see pages 92–94)

$C_p$  = Load Factor (from Figure 20)

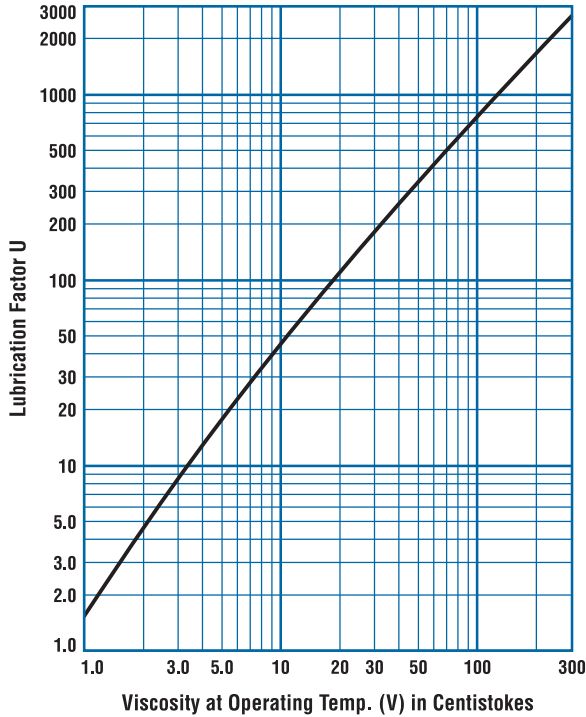
In calculating factor  $A_3$ , do not use a value greater than 3 or less than 1. (Outside these limits, the calculated life predictions, are unreliable.) A value less than 1 presumes poor lubrication conditions. If  $A_3$  is greater than 3, use 3.

Note: Silicone-based oils are generally unsuitable for speeds above 200,000 dN and require a 2/3 reduction in Basic Load Rating  $C$ .

# ENGINEERING

## Bearing Performance

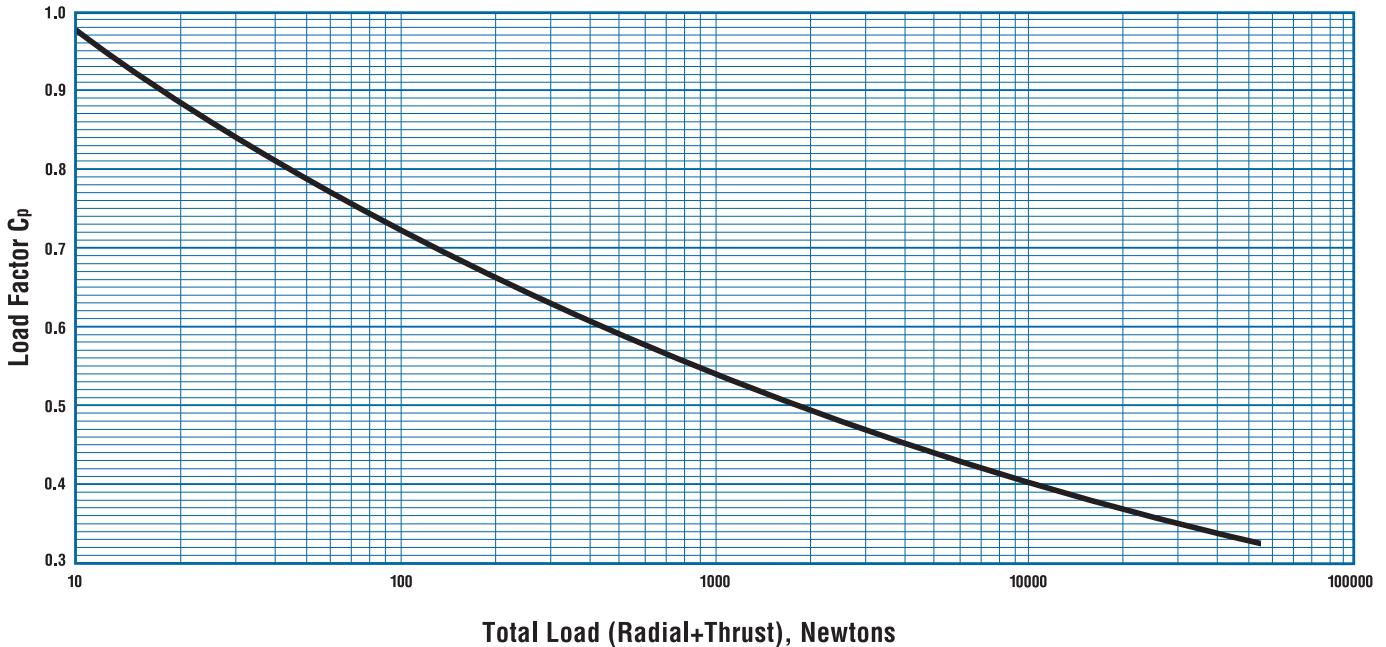
Fig. 19. Lubrication factor U.



### Sample Fatigue Life Calculation

Application Conditions	
Application	High-speed turbine
Operating speed	40,000 RPM
Rotating members	Shaft, Inner Ring
Lubrication	Oil Mist, Winsor Lube L-245X (MIL-L-6085, Barden Code 0-11)
Dead weight radial load	.50N. (spaced equally on two bearings)
Turbine thrust	.90N.
Thrust from preload spring	.70N.
Ambient temperature	.70°C
Tentative bearing choice	102HJH (vacuum processed SAE 52100 steel)

Fig. 20. Load factor Cp.



# ENGINEERING

## Bearing Performance

Step 1. Calculation of basic fatigue life in hours

Data for 102H (see product data section, pages 42–43):

$$C = 6240N$$

$$nd^2 = 0.3867$$

$$\text{Contact angle} = 15^\circ$$

$$\text{Total Thrust Load} = 90 + 70 = 160N$$

$$T/nd^2 = \frac{160}{.3867} = 413$$

$$\text{Radial Load Per Bearing} = 25N$$

From Table 38, page 116:  $X = 0.44$

$$Y = 1.31$$

$$P = XR + YT = (.44)(25) + (1.31)(160) = 220.6$$

$$L_{10} = \frac{16,666}{40,000} \times \left(\frac{6240}{220.6}\right)^3 = 9430 \text{ hours}$$

Answer: Basic fatigue life . . . . . 9430 hours

Step 2. Calculation of life modifying factors  $A_1$ - $A_3$

$$A_1 = 1 \text{ for } L_{10} \text{ from Table 39}$$

$$A_2 = 1 \text{ for vacuum processed SAE 52100 from Table 40}$$

$$A_3 = 8.27 \times 10^{-11} n C N U C_p \text{ for spindle and turbine bearings}$$

$$n = 11$$

$$C = 6240$$

$$N = 40,000$$

From graph on page 100, viscosity of Barden Code 0-11,  $70^\circ C = 5.7Cs$

$$\text{From Fig. 19, } U = 20$$

Determine  $C_p$ , Load Factor, from Figure 20:

$$\text{Total Load (Radial + Thrust)} = 25 + 160 = 185, C_p = 0.68$$

$$A_3 = 8.27 \times 10^{-11} \times 11 \times 6240 \times 40,000 \times 20 \times 0.68 = 3.088$$

Use maximum value of 3.0 for  $A_3$ .

Step 3. Calculation of modified fatigue life

$$L_{10} \text{ Modified} = A_1 A_2 A_3 L_{10} =$$

$$(1)(1)(3.00)9430 = 28,290 \text{ hours}$$

Answer: Modified fatigue life 28,290 hours

### Miscellaneous Life Considerations

Other application factors usually considered separately from  $A_3$  include high-speed centrifugal ball loading effects, varying operating conditions and installations of more than one bearing.

**High-speed centrifugal ball effects.** Fatigue life calculations discussed previously do not allow for centrifugal ball loading which starts to become significant at 750,000 dN. These effects require computerized analysis, which can be obtained by consulting Barden Product Engineering.

**Varying operating conditions.** If loads, speeds and modifying factors are not constant, bearing life can be determined by the following relationship:

$$L = \frac{1}{\frac{F_1}{L_1} + \frac{F_2}{L_2} + \frac{F_3}{L_3} + \frac{F_n}{L_n}}$$

in which

$F_n$  = Fraction of the total life under conditions 1, 2, 3, etc.

$$(F_1 + F_2 + F_3 + F_n = 1.0).$$

$L_n$  = The bearing life calculated for conditions 1, 2, 3, etc.

**Bearing sets.** When the life of tandem pairs (DT) or tandem triplex sets (DD) is being evaluated, the basic load rating should be taken as:

$$1.62 C \text{ for pairs}$$

$$2.16 C \text{ for triplex sets}$$

and the pair or triplex set treated as a single bearing. When determining Y values from Tables 37 or 38, the table should be entered with the following modifications for values of  $T/nd^2$ :

$$0.50 T/nd^2 \text{ for pairs}$$

$$0.33 T/nd^2 \text{ for triplex sets}$$

again, the pair or set should be treated as a single bearing.

The life of bearings mounted as DB or DF pairs and subjected to thrust loads is dependent on the preload, the thrust load and the axial yield properties of the pair. Consult Barden Product Engineering for assistance with this type of application.

# ENGINEERING

## Grease Life

In grease lubricated bearings life is often not determined by the internal design, fitting and specification of the bearing but by the grease itself. It is important for this reason to ensure appropriate running conditions to optimise useful grease life.

The life of the grease is dictated by the condition of the thickener. Acting as a sponge the thickener will retain oil within its structure, gradually releasing the oil for use. As the thickener breaks down, the rate of oil release will increase until all useful oil is consumed. Degradation of the thickener depends on many things including the thickener type, operating loads/conditions and temperature.

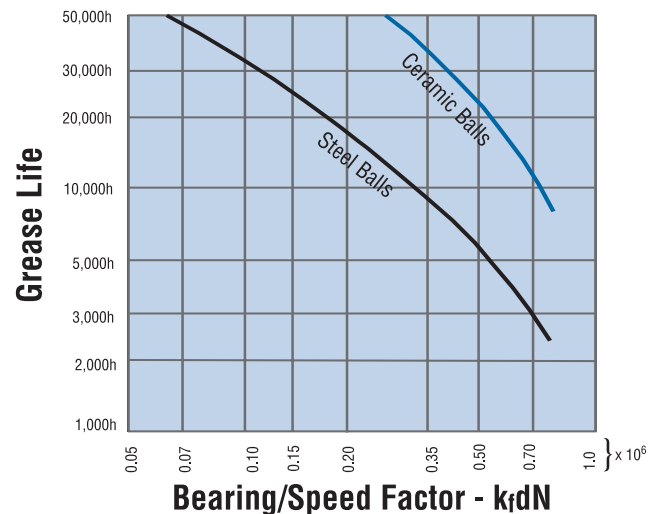
At low speeds the mechanical churning of the grease is minimal preserving the structure of the grease and its ability to retain oil, as speeds increase so to does the churning. Furthermore at high speeds the motion of the balls with respect to the raceways can generate additional churning. If control of the bearings is not maintained throughout the operating spectrum of the unit this can lead to rapid degradation of the grease and subsequent bearing failure.

To ensure that the bearings are operating under controlled conditions a suitable axial preload should be applied to the bearings. This prevents high ball excursions and differences in the operating contact angles between inner and outer races. For extreme high speed applications centrifugal ball loading can be detrimental to life.

At the other extreme of operating conditions, that of temperature, grease life can also be effected dramatically. With increased temperature levels the viscosity of the base oil will drop allowing a greater flow of oil from the thickener. Additionally the thickener selection is critical, if the thickener is not thermally stable it will be degraded at low speeds accelerating oil loss. As a general rule of thumb for each 10°C increase in the operating temperature of the bearing a 50% reduction in useful grease life can be expected.

The use of ceramic balls in bearing applications has been shown to improve useful grease life. With a superior surface finish the balls will maintain EHD lubrication under the generation of a thinner oil film. During the regimes of boundary and mixed lubrication wear levels between ball and race are greatly reduced due to the dissimilarity of the two materials. Generated wear particles contained in the grease can act as a catalyst for grease degradation as they themselves degrade. By limiting the amount of generated debris this catalytic action can also be limited, this can also be reduced further by the use of Cronidur 30 for the race materials.

**Fig. 21. Grease life computation for normal temperatures.**



Bearing Type	Values of $K_f$	
	K3	K5
Deep Groove M&I	0.8	0.9
Deep Groove S&T	0.9	1.1
Angular Contact M&I	0.85	
Angular Contact S&T	0.88	

Use this information a general guide only. Grease life is very dependent upon actual temperatures experienced within the bearing. Consequently, where performance is critical, the application should be reviewed with Barden Product Engineering.



# ENGINEERING

## Vibration

Performance of a bearing may be affected by vibration arising from exposure to external vibration or from self-generated frequencies.

### Effect of Imposed Vibration

Bearings that are subject to external vibration along with other adverse conditions can fail or degrade in modes known as false brinelling, wear oxidation or corrosion fretting. Such problems arise when loaded bearings operate without sufficient lubrication at very low speeds, oscillating or even stationary. When vibration is added, surface oxidation and selective wear result from minute vibratory movement and limited rolling action in the ball-to-raceway contact areas. The condition can be relieved by properly designed isolation supports and adequate lubrication.

### Vibration Sources

All bearings have nanometer variations of circular form in their balls and raceways. At operating speed, low level cyclic displacement can occur as a function of these variations, in combination with the speed of rotation and the internal bearing design. The magnitude of this cyclic displacement is usually less than the residual unbalance of the supported rotating member, and can be identified with vibration measuring equipment.

The presence of a pitched frequency in the bearings can excite a resonance in the supporting structure. The principal frequencies of ball bearing vibration can be identified from the bearing design and knowledge of variation-caused frequencies. Frequency analysis of the supporting structure is usually more difficult, but can be accomplished experimentally.

Monitoring vibration levels is an important tool in any preventive maintenance program. Vibration monitoring can detect abnormalities in components and indicate their replacement well before failure occurs. Knowledge of vibration levels helps reduce downtime and loss of production.

### System Vibration Performance

The overall vibration performance of a mechanical system (shafts, bearings, housing, external loads) is complex and often unpredictable. A lightly damped resonance can put performance outside acceptable criteria at specific speed ranges. This interaction of system resonances and bearing events is most pronounced in less-than-ideal designs (long, slender shafts, over-hung rotor masses, etc.). These designs are relatively uncommon, and require a lot of engineering effort to resolve. They are usually solved through a series of iterations, via ball counts, radial and axial stiffness, and other parameters.

# ENGINEERING

## Bearing Performance

### Yield Stiffness

A ball bearing may be considered elastic in that when either radial, axial or moment loading is applied, it will yield in a predictable manner. Due to its inherent design, the yield rate of a bearing decreases as the applied load is increased.

As previously discussed under Preloading, the yield characteristics of bearings are employed in preloaded duplex pairs to provide essentially linear yield rates. Yield must also be considered in figuring loads for duplex pairs and the effects of interference fits on established preloads.

The deflection and resonance of bearing support systems are affected by bearing yield; questions or problems that arise in these areas should be referred to the Barden Product Engineering Department.

### Torque

Starting torque, running torque and variations in torque levels can all be important to a bearing application. Starting torque – the moment required to start rotation – affects the power requirement of the system and may be crucial in such applications as gyro gimbals.

Running torque – the moment required to maintain rotation – is a factor in the system power loss during operation. Variations in running torque can cause errors in sensitive instrumentation applications.

To minimise bearing torque, it is important to consider internal bearing geometry and to have no contaminants present, minimal raceway and ball roundness variation, good finishes on rolling and sliding surfaces, and a lightweight, free-running cage.

The type and amount of lubricant must also be considered in determining bearing torque, but lubricant-related effects are often difficult to predict. This is particularly true as speeds increase, when an elastohydrodynamic film builds up between balls and races, decreasing the running torque significantly. Also influential are the viscosity/pressure coefficients of lubricants, which are affected by temperature.

Several aspects of bearing applications should be evaluated for their torque implications. For example, loading is relevant because torque generally increases in proportion to applied loads. Precision mounting surfaces, controlled fitting practices and careful axial adjustment should be employed to minimise torque.

Contact Barden Product Engineering Department for assistance in calculating actual torque values.

### Measurement and Testing

Barden's ability to manufacture reliable high precision bearings results from a strong commitment to quality control. All facets of bearing manufacture and all bearing components are subjected to comprehensive tests using highly sophisticated instruments and techniques, some of our own design.

Examples of the types of test regularly performed by Barden include metallurgical testing of bar stock; torque and vibration analysis; roundness and waviness, surface finish and raceway curvature measurement; preload offset gauging; and lubricant chemistry evaluation.

### Non-Destructive Testing

Non-destructive tests, i.e. those that evaluate without requiring that the test sample be damaged or destroyed, are among the most important that can be performed. Non-destructive tests can identify flaws and imperfections in bearing components that otherwise might not be detected.

Barden conducts many types of non-destructive tests, each designed to reveal potentially undesirable characteristics caused by manufacturing or material process flaws. Five of the most useful general purpose non-destructive tests are 1) liquid penetrant, 2) etch inspection, 3) magnetic particle, 4) eddy current, and 5) Barkhausen.

# ENGINEERING

## Bearing Performance

### Functional Testing

Because functional testing of assembled bearings can be extremely important, Barden has developed several proprietary testing instruments for this purpose.

Bearing-generated vibration and noise is checked by using either the Barden Smoothrator®, the Bendix Anderometer®, the FAG functional tester or the Barden Quiet Bearing Analyzer. The function of these instruments is to detect any problems relating to surface finish and damage in the rolling contact area, contamination and geometry. They are used as quality control devices by Barden, to ensure that we deliver quiet, smooth-running bearings, and also as a trouble-shooting aid to trace the causes of bearing malfunction.

Bearing running torque is measured by various instruments such as the Barden Torkintegrator. Starting torque can also be measured on special gauges.

Non-repetitive runout of a bearing – a function of race lobing, ball diameter variation and cleanliness – is gauged on proprietary Barden instruments.

Detailed spectral analysis at the functional test level gives an overview on how well the manufacturing of the components and the assembly of these components was performed. In the rare instances where the spectrum indicates something went wrong, we can quickly disassemble a new bearing and inspect the raceways, cages and balls to see if assembly damage or contaminants are an issue. If this is not the case, we can look further into the manufacturing process using waviness measurement to see if poor geometry was induced in the grinding or honing process.

This sequential series of checks allows us to rapidly identify production issues and maintain a premium level of quality in our product.

# ENGINEERING

## Bearing Application

### Mounting & Fitting

After a bearing selection has been made, the product or system designer should pay careful attention to details of bearing mounting and fitting.

Bearing seats on shafts and housings must be accurately machined, and should match the bearing ring

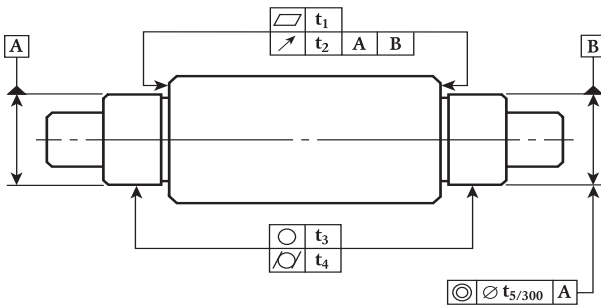


Table 41. Dimensional accuracy recommendations for shafts.

Characteristic	Outside Diameter of Shaft Bearing Seat, mm							
	<6	6-10	11-18	19-30	31-50	51-80	81-120	121-180
Flatness, $t_1$	0.8	1.5	2.0	2.5	2.5	3.0	3.8	5.1
Runout, $t_2$	1.0	2.5	3.0	3.8	3.8	5.1	6.4	7.6
Roundness, $t_3$	0.6	1.3	1.5	1.9	1.9	2.5	3.2	3.8
Taper, $t_4$	0.6	1.3	1.5	1.9	1.9	2.5	3.2	3.8
Concentricity, $t_5$	1.0	2.5	3.0	3.8	3.8	5.1	6.4	7.6

Values in micrometers.

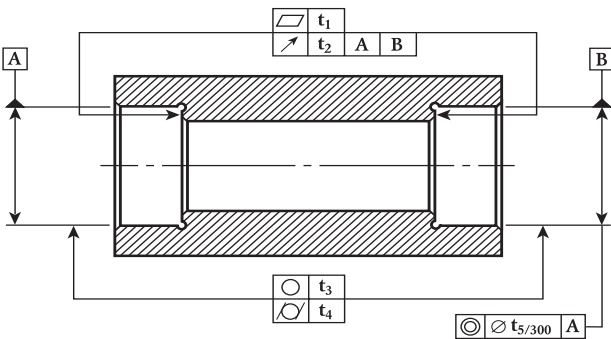


Table 42. Dimensional accuracy recommendations for housings.

Characteristic	Bore Diameter of Bearing Housing, mm							
	<10	10-18	19-30	31-50	51-80	81-120	121-180	181-250
Flatness, $t_1$	1.7	2.0	2.5	2.5	3.0	3.8	5.1	7.6
Runout, $t_2$	2.5	3.0	3.8	3.8	5.1	6.4	7.6	10.2
Roundness, $t_3$	1.5	1.9	2.5	3.2	3.8	3.8	5.1	6.4
Taper, $t_4$	1.3	1.5	1.9	1.9	2.5	3.2	3.8	5.1
Concentricity, $t_5$	2.5	3.0	3.8	3.8	5.1	6.4	7.6	10.2

Values in micrometers.

width to provide maximum seating surface.

Recommendations for geometry and surface finish of bearing seats and shoulders are shown in Table 43.

Dimensional accuracy recommendations for shafts and housings can be found in Tables 41 and 42.

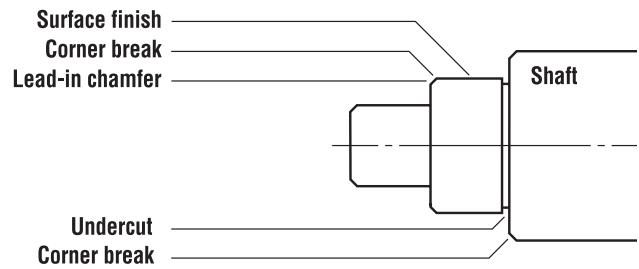


Table 43. Recommended finish of bearing seats and shoulders.

Detail or characteristic	Specification
Lead-in chamfer	Required
Undercut	Preferred
All corners	Burr-free at 5x magnification
Surface finish	0.4 micrometers CLA maximum
Bearing seats	Clean at 5x magnification

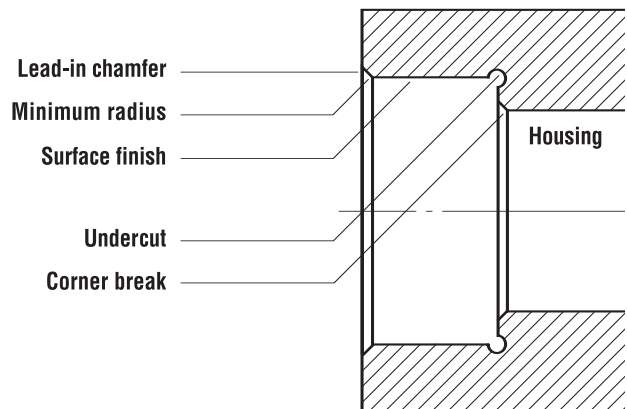


Table 44. Recommended geometry of corners.

Detail	Nominal Bore Diameter, mm			
	<6	6-50	51-120	121-180
Corner break, min.	25	50	76	100
Minimum radius	76	76	76	100

Values in micrometers.

# ENGINEERING

## Bearing Application

### Shaft & Housing Fits

The ideal mounting for a precision bearing has a line-to-line fit, both on the shaft and in the housing. Such an idealised fit has no interference or looseness.

As a practical matter, many influencing factors have to be considered:

- Operating conditions such as load, speed, temperature.
- Provision for axial expansion.
- Ease of assembly and disassembly.
- Requirements for rigidity and rotational accuracy.
- Machining tolerances.

Thus, the appropriate fit may have moderate interference, moderate looseness or even a transitional nature, as governed by operating requirements and the mounting design. Tables 45 and 46 provide general guidelines for typical applications, according to dominant requirements.

### Fitting Practice

Interference fits (press fits) may be required when there is:

- A need to avoid mass center shifts
- Heavy radial loading
- Vibration that could cause fretting and wear
- A need for heat transfer
- A lack of axial clamping
- To compensate for centrifugal growth of inner ring

Interference fits should be used cautiously, as they can distort the raceway and reduce radial play. In preloaded pairs, reduction of radial play increases the preload. If excessive, this can result in markedly reduced speed capability, higher operating temperature and premature failure.

Loose fits may be advisable when:

- There are axial clamping forces
- Ease of assembly is important
- There must be axial movement to accommodate spring loading or thermal movements

**Table 45. Shaft and housing fits for miniature and instrument bearings.**

	Dominant Requirements*		Fit Extremes, mm**	
			Random Fitting	Selective Fitting
<b>Shaft Fits</b>	Inner ring clamped	Normal accuracy	.000 -.010	-.003 -.008
		Very low runout, high radial rigidity.	+.003 -.008	.000 -.005
	Inner ring not clamped	Normal accuracy	+.003 -.008	.000 -.005
		Very low runout, high radial rigidity.	+.008 -.003	+.005 .000
		Very high speed service	+.005 -.005	+.003 -.003
		Inner ring must float to allow for expansion	.000 -.010	-.003 -.008
		Inner ring must hold fast to rotating shaft	+.008 -.003	+.005 .000
<b>Housing Fits</b>	Normal accuracy, low to high speeds. Outer ring can move readily in housing for expansion.		.000 -.010	-.003 -.008
	Very low runout, high radial rigidity. Outer ring need not move readily to allow for expansion.		+.003 -.008	.000 -.005
	Heavy radial load. Outer ring rotates.		+.003 -.008	.000 -.005
	Outer ring must hold fast to rotating housing. Outer ring not clamped.		+.010 .000	+.008 +.003

\*Radial loads are assumed to be stationary with respect to rotating ring.

\*\*Interference fits are positive (+) and loose fits negative (-) for use in shaft and housing size determination, page 127.

# ENGINEERING

## Bearing Application

Loose fits for stationary rings can be a problem if there is a dominant rotating radial load (usually unbalanced). While axial clamping, tighter fits and anti-rotation devices can help, a better solution is good dynamic balancing of rotating mass.

The appropriate fit may also vary, as governed by operating requirements and mounting design. To ensure a proper fit, assemble only clean, burr-free parts. Even small amounts of dirt on the shaft or housing can cause severe bearing misalignment problems.

When press fitting bearings onto a shaft, force should be applied evenly and only to the ring being fitted or internal damage to the bearing – such as brinelling

– could result. If mounting of bearings remains difficult, selective fitting practices should be considered. Selective fitting – utilising a system of bearing calibration – allows better matching of bearing, shaft and housing tolerances, and can provide more control over assembly.

### Fitting Notes:

1. Before establishing tight interference fits, consider their effect on radial internal clearance and bearing preloads (if present). Also realise that inaccuracies in shaft or housing geometry may be transferred to the bearings through interference fits.

**Table 46. Shaft and housing fits for spindle and turbine bearings.**

	Dominant Requirements*		Fit Extremes, mm**			
			Nominal Bore Diameter, mm			
			7–30	31–80	81–180	
Shaft Fits	Inner ring clamped	Very low runout, high radial rigidity.	+ .005 – .003	+ .008 – .003	+ .010 – .005	
		Low to high speeds, low to moderate radial loads.	+ .004 – .004	+ .005 – .005	+ .008 – .008	
		Heavy radial load	Inner ring rotates	+ .008 .000	+ .010 .000	+ .015 .000
			Outer ring rotates	.000 – .008	+ .003 – .008	+ .003 – .013
		Inner ring not clamped	Very low runout, high radial rigidity, light to moderate radial loads.	+ .008 .000	+ .010 .000	+ .015 .000
			Heavy radial load	Inner ring rotates	+ .010 + .003	+ .013 + .003
	Outer ring rotates			.000 – .008	+ .003 – .008	+ .003 – .013
	Inner ring must float to allow for expansion, low speed only.		.000 – .008	– .003 – .013	– .005 – .020	
				Nominal Outside Diameter, mm		
				18–80	81–120	121–250
Housing Fits	Normal accuracy, low to high speeds, moderate temperature.		.000 – .010	+ .003 – .013	+ .005 – .015	
	Very low runout, high radial rigidity. Outer ring need not move readily to allow for expansion.		+ .003 – .008	+ .005 – .010	+ .005 – .015	
	High temperature, moderate to high speed. Outer ring can move readily to allow for expansion.		– .003 – .013	– .003 – .018	– .005 – .025	
	Heavy radial load, outer ring rotates.		+ .010 .000	+ .015 .000	+ .020 .000	

\*Radial loads are assumed to be stationary with respect to rotating ring.

\*\*Interference fits are positive (+) and loose fits negative (–) for use in shaft and housing size determination, page 127.

# ENGINEERING

## Bearing Application

2. Radial internal clearance is reduced by up to 80% of an interference fit. Thus, an interference of .005mm could cause an estimated .004mm decrease in internal clearance. Bearings with Code 3 radial play or less should have little or no interference fitting.
3. Keep in mind that mounting fits may be substantially altered at operating temperatures due to differential expansion of components. Excessive thermal expansion can quickly cause bearing failure if the radial play is reduced to zero or less, creating a radial preload.
4. An axially floating loose fit for one bearing of two-bearing system is usually needed to avoid preloading caused by thermal expansion during operation.
5. When an interference fit is used, it is generally applied to the rotating ring. The stationary ring is fitted loose for ease of assembly.
6. Spring-loaded bearings require a loose fit to ensure that the spring loading remains operational.
7. In the case of loose fits, inner and outer rings should be clamped against shoulders to minimise the possibility of non-repetitive runout.
8. Diameter and squareness tolerances for shaft and housing mounting surfaces and shoulders should be similar to those for the bearing bore and O.D. The surface finish and hardness of mating components should be suitable for prolonged use, to avoid deterioration of fits during operation.
9. Proper press-fitting techniques must be used to prevent damage during assembly. Mounting forces must never be transmitted through the balls from one ring to the other. Thus, if the inner ring is being press fitted, force must be applied directly to the inner ring.
10. When a more precise fit is desired, bearings can be obtained that are calibrated into narrower bore and O.D. tolerance groups. These can be matched to similarly calibrated shafts and housings to cut the fit tolerance range by 50% or more.
11. Mounting bearings directly in soft non-ferrous alloy housings is considered poor practice unless loads are very light and temperatures are normal and steady – not subject to wide extremes. When temperatures vary drastically as in aircraft applications, where aluminum is a common structural material, steel housing liners should be used to resist the effects of excessive thermal contraction or expansion upon bearing fits. Such liners should be carefully machined to the required size and tolerance while in place in the housing, to minimise possibility of runout errors.  
  
Other problems associated with non-ferrous alloys are galling during assembly and “pounding out” of bearing seats. Any questions that arise in unusual mounting situations should be discussed with the Barden Product Engineering Department.
12. For a more secure mounting of a bearing on a shaft or in a housing, clamping plates are considered superior to threaded nuts or collars. Plates are easily secured with separate screws.

When used with shafts and housings that are not shouldered, threaded nuts or collars can misalign bearings. Care must be taken to assure that threaded members are machined square to clamping surfaces. For high-speed precision applications, it may be necessary to custom scrape the contact faces of clamping nuts. In all cases, the clamping forces developed should not be capable of distorting the mating parts.

### Shaft and Housing Size Determination

The fits listed in Tables 45 and 46 (pages 125 and 126) apply to normal operating temperatures and are based on average O.D. and bore sizes. The size and tolerance of the shaft or housing for a particular application can be readily computed by working back from the resulting fit, as shown in the example. Note that the total fit tolerance is always the sum of the bearing bore or O.D. tolerance plus the mating shaft or housing tolerance.

# ENGINEERING

## Bearing Application

Example: Determination of shaft and housing size for a 204H bearing installation in a high speed cooling turbine.

	<b>Bore</b>	<b>O.D.</b>
204HJH nominal diameter	20mm (.7874")	47mm (1.8504")
204HJH tolerance from Table 36 (page 113)	+0.000mm -0.005mm	+0.000 -0.006mm
Actual diameter range	20.000/19.995mm	47.000/46.994mm

Desired fit chosen for this application  
(data from Table 46, page 126)

On shaft: +.005mm (tight) / -.003mm (loose)

In housing: .000mm (line-to-line) / -.010mm (loose)

### DETERMINING SHAFT O.D.

Tightest fit is with maximum shaft O.D. and minimum bearing bore diameter:

Minimum bearing bore diameter	19.995mm
Add: tightest fit extreme	0.005mm
Maximum Shaft O.D.	20.000mm

Loosest fit is with minimum shaft O.D. and maximum bearing bore diameter:

Maximum bearing bore diameter	20.000mm
Subtract: loosest fit extreme	0.003mm
Minimum Shaft O.D.	19.997mm

### DETERMINING HOUSING I.D.

Tightest fit is with maximum bearing O.D. and minimum housing I.D.:

Maximum bearing O.D.	47.000mm
Subtract: tightest fit extreme	0.000mm
Minimum housing I.D.	47.000mm

Loosest fit is with minimum bearing O.D. and maximum housing I.D.:

Minimum bearing O.D.	46.994mm
Add: loosest fit extreme	0.010mm
Maximum housing I.D.	47.004mm

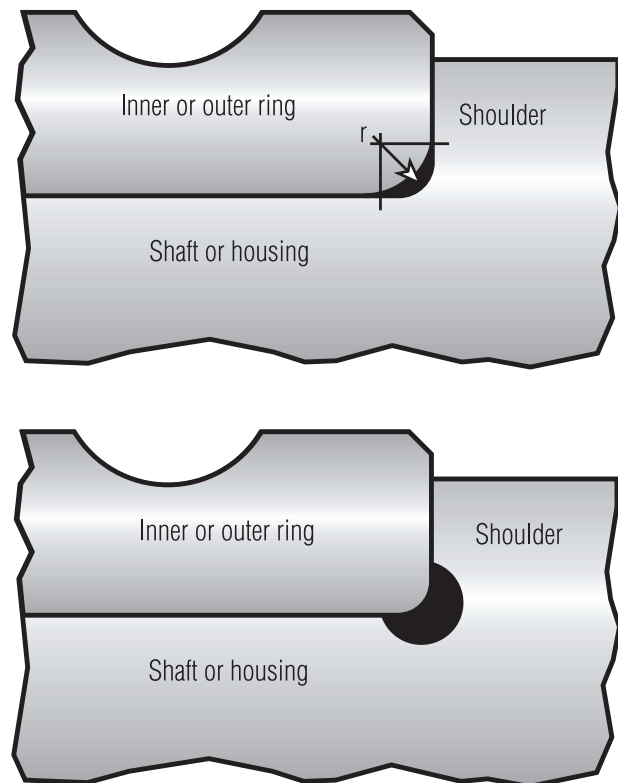
### Maximum fillet radii

When a shaft or housing has integral shoulders for bearing retention, fillet radii of the shoulders must clear the corners of inner and outer rings to allow accurate seating of the bearing.

All product listings in the front of this catalogue and the shoulder diameter tables include values for maximum fillet radii. In the case of angular contact bearings, the smaller value  $r_i$  or  $r_o$  should be used when the cutaway side (non-thrust face) of the inner or outer ring is mounted against a solid shoulder.

Fig. 22 illustrates two methods of providing clearance for the bearing corner. In the upper view, fillet radius  $r$  is the maximum that the bearing will clear. The undercut fillet shown at bottom is preferred because it allows more accurate machining of the shoulder and seat, and permits more accurate bearing mounting.

Fig. 22. Two methods of providing clearance for bearing corner.





# ENGINEERING

## Bearing Application

### Shaft and Housing Shoulder Diameters

Shaft and housing shoulders must be high enough to provide accurate, solid seating with good alignment and support under maximum thrust loading. At the same time, the shoulders should not interfere with bearing cages, shields or seals. This caution is particularly important when bearings have high values of radial play and are subject to heavy thrust loads.

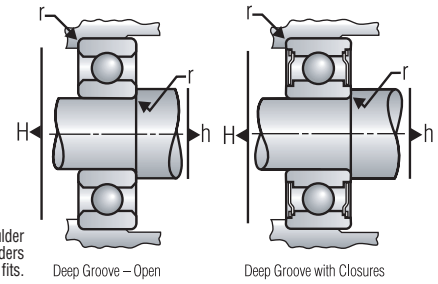
Besides being high enough for good seating, shoulders should be low enough to allow use of bearing tools against appropriate ring faces when bearings are dismantled, to avoid damage from forces transmitted through the balls. This caution applies especially to interference-fitted bearings that are going to be used again after dismantling.

Spacers, sleeves or other parts may be used to provide shoulders as long as recommended dimensional limits are observed. When possible, the rotating ring of a bearing should be located against an accurately machined surface on at least one face.

In high-speed applications where oil spray or mist lubrication systems are used, shoulder design may be extremely important because it is essential that lubricant flow be effective and unimpeded.

# ENGINEERING

## Deep Groove Instrument (inch) Abutments



When planned applications involve bearing removal and remounting, shoulder dimensions should be selected to facilitate dismounting. Minimum shaft shoulders and maximum housing shoulders are preferred, particularly with interference fits.

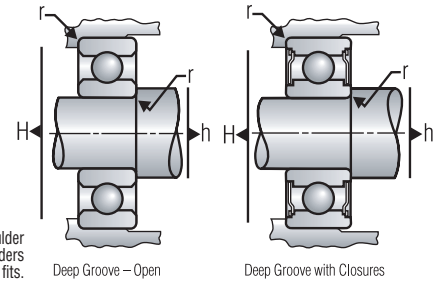
**Table 47. Shaft and housing shoulder diameter abutment dimensions for deep groove instrument (inch) bearings.**

Bearing Number	Bearing Dimensions				Maximum Shaft/Housing Fillet Radius Which Bearing Corner Will Clear			Shaft Shoulder Diameters				Housing Shoulder Diameters			
	Bore Dia.	Outside Dia.	Relieved Face Diameter		r	r <sub>i</sub>	r <sub>o</sub>	Open		Shielded or Sealed		Open		Shielded or Sealed	
			O <sub>i</sub>	O <sub>o</sub>				h min.	h max.	h min.	h max.	H min.	H max.	H min.	H max.
SR0	1.191	3.967	—	—	0.08	—	—	1.803	1.956	1.803	1.956	3.099	3.353	3.251	3.353
SR1	1.397	4.763	—	—	0.08	—	—	2.007	2.362	2.007	2.362	3.785	4.166	3.937	4.166
SR1-4	1.984	6.350	—	—	0.08	—	—	2.591	3.962	2.591	3.962	5.359	5.740	5.512	5.740
SR133*	2.380	4.763	—	—	0.08	—	—	2.896	2.972	2.896	2.972	4.089	4.267	4.191	4.267
SR143	2.380	6.350	—	—	0.08	—	—	—	—	2.896	3.962	—	—	5.512	5.740
SR1-5	2.380	7.938	—	—	0.13	—	—	3.099	4.191	3.099	4.191	6.248	7.214	7.036	7.214
SR144*	3.175	6.350	—	—	0.08	—	—	3.759	3.962	3.759	3.962	5.359	5.740	5.512	5.740
SR144X3	3.175	6.350	—	—	0.08	—	—	—	—	3.759	3.962	—	—	5.512	5.740
SR2-5X2	3.175	7.938	—	—	0.08	—	—	—	—	3.886	4.191	—	—	7.036	7.214
SR154X1	3.175	7.938	—	—	0.08	—	—	—	—	3.759	3.962	—	—	5.512	7.214
SR2-5	3.175	7.938	—	—	0.08	—	—	3.886	4.470	3.886	4.191	6.629	7.214	7.036	7.214
SR2X52	3.175	9.525	—	—	0.15	—	—	—	—	3.886	5.029	—	—	7.722	8.255
SR2-6	3.175	9.525	—	—	0.15	—	—	3.886	5.080	3.886	5.080	7.620	8.814	8.280	8.814
SR164X3	3.175	9.525	—	—	0.08	—	—	—	—	3.759	3.962	—	—	5.512	8.814
SR2	3.175	9.525	—	—	0.30	—	—	4.547	5.080	4.547	5.080	7.620	8.255	8.128	8.255
SR174X5	3.175	10.414	—	—	0.08	—	—	—	—	3.759	3.962	—	—	5.766	8.661
SR174X2	3.175	10.795	—	—	0.08	—	—	—	—	4.547	5.029	—	—	7.722	9.500
SR184X2	3.175	12.700	—	—	0.08	—	—	—	—	3.759	3.962	—	—	5.512	11.328
SR2A	3.175	12.700	—	—	0.30	—	—	4.547	4.623	4.547	4.623	8.128	11.328	8.128	11.328
SR1204X1	3.175	19.050	—	—	0.13	—	—	—	—	5.715	5.969	—	—	8.712	16.510
SR155	3.967	7.938	—	—	0.08	—	—	4.572	5.639	4.572	5.639	7.112	7.315	7.264	7.315
SR156*	4.763	7.938	—	—	0.08	—	—	5.334	5.639	5.334	5.639	7.112	7.315	7.264	7.315
SR156X1	4.763	7.938	—	—	0.08	—	—	—	—	5.334	5.639	—	—	7.264	7.315
SR166*	4.763	9.525	—	—	0.08	—	—	5.486	5.969	5.486	5.969	8.255	8.814	8.661	8.814
SR186X3	4.763	12.700	—	—	0.13	—	—	—	—	5.486	5.969	—	—	8.661	11.328
SR186X2	4.763	12.700	—	—	0.13	—	—	—	—	5.486	5.969	—	—	8.661	11.328
SR3	4.763	12.700	—	—	0.30	—	—	6.198	7.010	6.198	6.401	10.465	11.328	10.922	11.328
SR3X8	4.763	19.050	—	—	0.30	—	—	—	—	6.198	6.401	—	—	10.922	17.221
SR3X23	4.763	22.225	—	—	0.30	—	—	—	—	6.198	6.401	—	—	10.922	20.295
SR168	6.350	9.525	—	—	0.08	—	—	6.909	7.214	6.909	7.214	8.712	8.941	8.865	8.941
SR188*	6.350	12.700	—	—	0.13	—	—	7.214	8.382	7.214	7.874	10.668	11.836	11.074	11.836
SR4	6.350	15.875	—	—	0.30	—	—	7.874	9.271	7.874	8.179	13.005	14.351	13.894	14.351
SR4A	6.350	19.050	—	—	0.41	—	—	8.179	9.804	8.179	8.687	15.138	17.221	16.408	17.221
SR4X35	6.350	26.619	—	—	0.30	—	—	—	—	7.874	8.179	—	—	13.894	24.892
SR1810	7.938	12.700	—	—	0.13	—	—	8.814	9.169	8.814	9.169	11.811	12.090	11.811	12.090
SR6	9.525	22.225	—	—	0.41	—	—	11.455	13.208	11.455	11.989	18.898	20.295	19.914	20.295
SR8	12.700	28.575	—	—	0.41	—	—	15.875	18.694	15.875	17.323	24.689	26.035	25.730	26.035
SR10	15.875	34.925	—	—	0.79	—	—	19.050	22.733	19.050	21.209	29.286	31.750	30.861	31.750

All dimensions in millimeters. \*Applies also to extended ring versions.

# ENGINEERING

## Deep Groove Instrument (metric) Abutments



When planned applications involve bearing removal and remounting, shoulder dimensions should be selected to facilitate dismounting. Minimum shaft shoulders and maximum housing shoulders are preferred, particularly with interference fits.

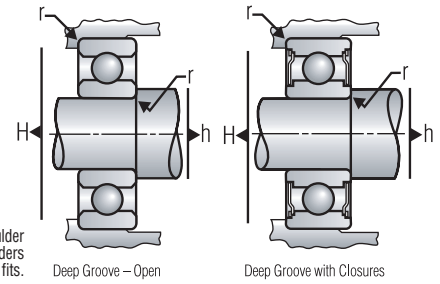
**Table 48. Shaft and housing shoulder diameter abutment dimensions for deep groove instrument (metric) bearings.**

Bearing Number	Bearing Dimensions				Maximum Shaft/Housing Fillet Radius Which Bearing Corner Will Clear			Shaft Shoulder Diameters				Housing Shoulder Diameters			
	Bore Dia.	Outside Dia.	Relieved Face Diameter		r	r <sub>i</sub>	r <sub>o</sub>	Open		Shielded or Sealed		Open		Shielded or Sealed	
			O <sub>i</sub>	O <sub>o</sub>				h min.	h max	h min.	h max	H min.	H max	H min.	H max
S18M1-5	1.500	4.000	—	—	0.08	—	—	2.007	2.159	—	—	2.997	3.175	—	—
S19M1-5	1.500	5.000	—	—	0.15	—	—	2.896	2.972	2.896	2.972	4.089	4.267	4.191	4.267
S19M2	2.000	6.000	—	—	0.15	—	—	3.073	3.200	3.073	3.200	5.105	5.232	5.105	5.232
S18M2-5	2.500	6.000	—	—	0.15	—	—	3.404	3.531	—	—	4.978	5.232	—	—
S38M2-5	2.500	6.000	—	—	0.15	—	—	3.404	3.531	3.404	3.531	5.283	5.410	5.283	5.410
S19M2-5	2.500	7.000	—	—	0.15	—	—	3.759	3.962	3.759	3.962	5.588	5.715	5.588	5.715
S38M3	3.000	7.000	—	—	0.15	—	—	4.013	4.140	4.013	4.140	6.198	6.325	6.198	6.325
S2M3	3.000	10.000	—	—	0.15	—	—	4.547	5.080	4.547	5.080	8.128	8.255	8.128	8.255
S18M4	4.000	9.000	—	—	0.18	—	—	4.826	5.080	—	—	7.620	7.925	—	—
S38M4	4.000	9.000	—	—	0.15	—	—	4.547	5.080	4.547	5.080	8.128	8.255	8.128	8.255
S2M4	4.000	13.000	—	—	0.18	—	—	6.198	7.010	6.198	7.010	10.922	11.328	10.922	11.328
34	4.000	16.000	—	—	0.30	—	—	5.639	7.493	5.639	7.493	12.497	14.122	13.894	14.122
S19M5	5.000	13.000	—	—	0.15	—	—	7.214	8.382	7.214	7.874	10.668	11.836	11.074	11.836
34-5	5.000	16.000	—	—	0.30	—	—	5.639	7.493	5.639	6.502	12.497	14.122	13.894	14.122
35	5.000	19.000	—	—	0.30	—	—	6.629	9.728	6.629	8.687	15.138	17.120	16.408	17.120
36	6.000	19.000	—	—	0.30	—	—	7.620	9.728	7.620	8.687	15.138	17.120	16.408	17.120
S18M7Y2	7.000	14.000	—	—	0.15	—	—	8.560	9.068	—	—	11.938	12.446	—	—
37	7.000	22.000	—	—	0.30	—	—	8.636	11.760	8.636	10.541	17.577	20.117	18.898	20.117
37X2	7.000	22.000	—	—	0.30	—	—	—	—	8.636	10.541	—	—	18.898	20.117
38	8.000	22.000	—	—	0.30	—	—	9.627	11.760	9.627	10.541	17.577	20.117	18.898	20.117
38X2	8.000	22.000	—	—	0.30	—	—	—	—	9.627	10.541	—	—	18.898	20.117
38X6	8.000	24.000	—	—	0.30	—	—	—	—	9.627	10.541	—	—	18.898	22.098
39	9.000	26.000	—	—	0.41	—	—	11.430	14.808	11.430	13.894	21.260	23.470	22.682	23.470

All dimensions in millimeters.

# ENGINEERING

## Deep Groove Flanged (inch) Abutments



When planned applications involve bearing removal and remounting, shoulder dimensions should be selected to facilitate dismounting. Minimum shaft shoulders and maximum housing shoulders are preferred, particularly with interference fits.

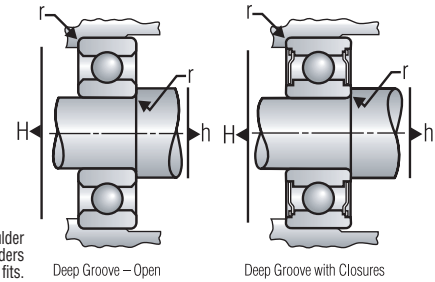
**Table 49. Shaft and housing shoulder diameter abutment dimensions for deep groove flanged (inch) bearings.**

Bearing Number	Bearing Dimensions				Maximum Shaft/Housing Fillet Radius Which Bearing Corner Will Clear			Shaft Shoulder Diameters				Housing Shoulder Diameters			
	Bore Dia.	Outside Dia.	Relieved Face Diameter		r	r <sub>i</sub>	r <sub>o</sub>	Open		Shielded or Sealed		Open		Shielded or Sealed	
			O <sub>i</sub>	O <sub>o</sub>				h min.	h max.	h min.	h max.	H min.	H max.	H min.	H max.
SFR0	1.191	3.967	—	—	0.08	—	—	1.803	1.956	1.803	1.956	3.099	3.353	3.251	3.353
SFR1	1.397	4.763	—	—	0.08	—	—	2.007	2.362	2.007	2.362	3.785	4.166	3.937	4.166
SFR1-4	1.984	6.350	—	—	0.08	—	—	2.591	3.962	2.591	3.962	5.359	5.740	5.512	5.740
SFR133*	2.380	4.763	—	—	0.08	—	—	2.896	2.972	2.896	2.972	4.089	4.267	4.191	4.267
SFR1-5	2.380	7.938	—	—	0.08	—	—	3.099	4.191	3.099	4.191	6.248	7.214	7.036	7.214
SFR144*	3.175	6.350	—	—	0.08	—	—	3.759	3.962	3.759	3.962	5.359	5.740	5.512	5.740
SFR2-5	3.175	7.938	—	—	0.08	—	—	3.886	4.470	3.886	4.191	6.629	7.214	7.036	7.214
SFR2-6	3.175	9.525	—	—	0.15	—	—	3.886	5.080	3.886	5.080	7.620	8.814	8.280	8.814
SFR2	3.175	9.525	—	—	0.30	—	—	4.547	5.080	4.547	5.080	7.620	8.255	8.128	8.255
SFR155	3.967	7.938	—	—	0.08	—	—	4.572	5.639	4.572	5.639	7.112	7.315	7.264	7.315
SFR156*	4.763	7.938	—	—	0.08	—	—	5.334	5.639	5.334	5.639	7.112	7.315	7.264	7.315
SFR166*	4.763	9.525	—	—	0.08	—	—	5.486	5.969	5.486	5.969	8.255	8.814	8.661	8.814
SFR3X3	4.763	12.700	—	—	0.30	—	—	6.198	7.010	—	—	10.465	11.328	—	—
SFR3	4.763	12.700	—	—	0.30	—	—	6.198	7.010	6.198	6.401	10.465	11.328	10.922	11.328
SFR168	6.350	9.525	—	—	0.08	—	—	6.909	7.214	6.909	7.214	8.712	8.941	8.865	8.941
SFR188*	6.350	12.700	—	—	0.13	—	—	7.214	8.382	7.214	7.874	10.668	11.836	11.074	11.836
SFR4	6.350	15.875	—	—	0.30	—	—	7.874	9.271	7.874	8.179	13.005	14.351	13.894	14.351
SFR1810	7.938	12.700	—	—	0.13	—	—	8.814	9.169	8.814	9.169	11.811	12.090	11.811	12.090
SFR6	9.525	22.225	—	—	0.41	—	—	11.455	13.208	11.455	11.989	18.898	20.295	19.914	20.295

All dimensions in millimeters. \*Applies also to extended ring versions.

# ENGINEERING

## Deep Groove Thin Section (inch) 500 and 1000 Series Abutments



When planned applications involve bearing removal and remounting, shoulder dimensions should be selected to facilitate dismounting. Minimum shaft shoulders and maximum housing shoulders are preferred, particularly with interference fits.

**Table 50. Shaft and housing shoulder diameter abutment dimensions for deep groove thin section 500 series (inch) bearings.**

Bearing Number	Bearing Dimensions				Maximum Shaft/Housing Fillet Radius Which Bearing Corner Will Clear			Shaft Shoulder Diameters				Housing Shoulder Diameters			
	Bore Dia.	Outside Dia.	Relieved Face Diameter		r	r <sub>i</sub>	r <sub>o</sub>	Open		Shielded or Sealed		Open		Shielded or Sealed	
			O <sub>i</sub>	O <sub>o</sub>				h min.	h max	h min.	h max	H min.	H max	H min.	H max
SN538	15.875	26.988	—	—	0.38	—	—	18.415	19.634	18.415	19.634	24.181	24.435	24.892	24.435
A538	15.875	26.988	—	—	0.38	—	—	18.415	19.634	18.415	19.634	24.181	24.435	24.892	24.435
SN539	19.050	30.163	—	—	0.38	—	—	21.590	22.708	21.590	22.708	27.381	27.635	24.181	27.635
A539	19.050	30.163	—	—	0.38	—	—	21.590	22.708	21.590	22.708	27.381	27.635	24.181	27.635
SN540	22.225	33.338	—	—	0.38	—	—	24.765	25.883	24.765	25.883	30.531	30.785	27.381	30.785
A540	22.225	33.338	—	—	0.38	—	—	24.765	25.883	24.765	25.883	30.531	30.785	27.381	30.785
SN541	26.988	38.100	—	—	0.38	—	—	29.540	30.734	29.540	30.734	35.306	35.560	30.531	35.560
A541	26.988	38.100	—	—	0.38	—	—	29.540	30.734	29.540	30.734	35.306	35.560	30.531	35.560
SN542	33.338	44.450	—	—	0.38	—	—	35.890	37.084	35.890	37.084	41.656	41.910	35.306	41.910
A542	33.338	44.450	—	—	0.38	—	—	35.890	37.084	35.890	37.084	41.656	41.910	35.306	41.910
SN543	39.688	50.800	—	—	0.38	—	—	42.240	43.332	42.240	43.332	48.006	48.260	41.656	48.260
A543	39.688	50.800	—	—	0.38	—	—	42.240	43.332	42.240	43.332	48.006	48.260	41.656	48.260

All dimensions in millimeters.

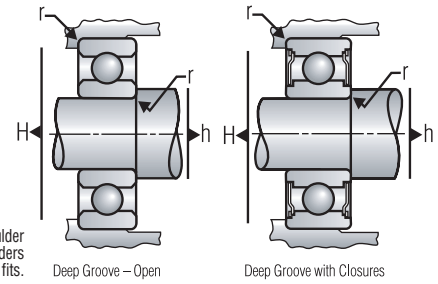
**Table 51. Shaft and housing shoulder diameter abutment dimensions for deep groove thin section 1000 series (inch) bearings.**

Bearing Number	Bearing Dimensions				Maximum Shaft/Housing Fillet Radius Which Bearing Corner Will Clear			Shaft Shoulder Diameters				Housing Shoulder Diameters			
	Bore Dia.	Outside Dia.	Relieved Face Diameter		r	r <sub>i</sub>	r <sub>o</sub>	Open		Shielded or Sealed		Open		Shielded or Sealed	
			O <sub>i</sub>	O <sub>o</sub>				h min.	h max	h min.	h max	H min.	H max	H min.	H max
SR1012	9.525	15.875	—	—	0.25	—	—	11.049	11.430	11.049	11.430	13.843	14.351	13.843	14.351
SWR1012	9.525	15.875	—	—	0.25	—	—	11.049	11.430	11.049	11.430	13.843	14.351	13.843	14.351
SR1216	12.700	19.050	—	—	0.25	—	—	14.224	14.605	14.224	14.605	17.145	17.526	17.145	17.526
SR1420	15.875	22.225	—	—	0.25	—	—	17.450	17.780	17.450	17.780	20.320	20.726	20.320	20.726
SR1624	19.050	25.400	—	—	0.25	—	—	20.625	20.955	20.625	20.955	23.495	23.901	23.495	23.901

All dimensions in millimeters.

# ENGINEERING

## Deep Groove Spindle & Turbine (metric) Abutments



When planned applications involve bearing removal and remounting, shoulder dimensions should be selected to facilitate dismounting. Minimum shaft shoulders and maximum housing shoulders are preferred, particularly with interference fits.

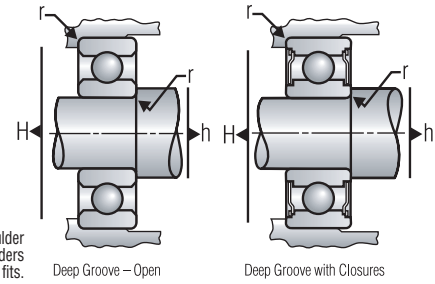
**Table 52. Shaft and housing shoulder diameter abutment dimensions for deep groove spindle & turbine (metric) bearings.**

Bearing Number	Bearing Dimensions				Maximum Shaft/Housing Fillet Radius Which Bearing Corner Will Clear			Shaft Shoulder Diameters				Housing Shoulder Diameters			
	Bore Dia.	Outside Dia.	Relieved Face Diameter		r	r <sub>i</sub>	r <sub>o</sub>	Open		Shielded or Sealed		Open		Shielded or Sealed	
			O <sub>i</sub>	O <sub>o</sub>				h min.	h max.	h min.	h max.	H min.	H max.	H min.	H max.
100	10.000	26.000	—	—	0.30	—	—	12.548	12.764	12.540	12.764	23.292	24.120	23.292	24.120
100X1	10.000	26.000	—	—	0.30	—	—	12.540	12.764	12.540	12.764	23.292	24.120	23.292	24.120
200	10.000	30.000	—	—	0.64	—	—	13.048	14.630	13.048	14.630	26.162	26.952	26.162	26.952
200X1	10.000	30.000	—	—	0.64	—	—	13.048	14.630	13.048	14.630	26.162	26.952	26.162	26.952
101	12.000	28.000	—	—	0.30	—	—	14.539	14.986	14.539	14.986	25.298	24.953	25.298	24.953
101X1	12.000	28.000	—	—	0.30	—	—	14.539	14.986	14.539	14.986	25.298	24.953	25.298	24.953
201	12.000	32.000	—	—	0.64	—	—	16.048	16.274	16.048	16.274	28.448	28.951	28.448	28.951
9201	12.000	32.000	—	—	0.64	—	—	16.048	16.274	16.048	16.274	28.448	28.951	28.448	28.951
201X1	13.000	32.000	—	—	0.64	—	—	16.048	16.274	16.048	16.274	28.448	28.951	28.448	28.951
1902X1	15.000	28.000	—	—	0.30	—	—	17.541	17.831	17.541	17.831	25.400	25.766	25.400	25.766
102	15.000	32.000	—	—	0.30	—	—	17.541	18.593	17.541	18.593	28.473	29.611	28.473	29.611
102X1	15.000	32.000	—	—	0.30	—	—	17.541	18.593	17.541	18.593	28.473	29.611	28.473	29.611
202	15.000	35.000	—	—	0.64	—	—	18.049	18.161	18.049	18.161	31.572	31.953	31.572	31.953
202X1	15.000	35.000	—	—	0.64	—	—	18.049	18.161	18.049	18.161	31.572	31.953	31.572	31.953
9302X1	15.000	42.000	—	—	1.00	—	—	19.065	21.488	19.065	21.488	35.357	37.935	35.357	37.935
103	17.000	35.000	—	—	0.30	—	—	20.048	20.180	20.048	20.180	31.369	31.445	31.369	31.445
203	17.000	40.000	—	—	0.64	—	—	20.556	21.641	20.556	21.641	35.357	36.444	35.357	36.444
9203	17.000	40.000	—	—	0.64	—	—	20.556	21.641	20.556	21.641	35.357	36.444	35.357	36.444
104	20.000	42.000	—	—	0.64	—	—	23.556	24.130	23.556	24.130	37.541	38.443	37.541	38.443
204	20.000	47.000	—	—	1.00	—	—	24.572	26.670	24.572	26.670	41.402	42.428	41.402	42.428
9204	20.000	47.000	—	—	1.00	—	—	24.572	26.670	24.572	26.670	41.402	42.428	41.402	42.428
105	25.000	47.000	—	—	0.64	—	—	28.557	29.235	28.557	29.235	42.545	43.444	42.545	43.444
205	25.000	52.000	—	—	1.00	—	—	29.573	31.496	29.573	31.496	46.228	47.427	46.228	47.427
9205	25.000	52.000	—	—	1.00	—	—	29.573	31.496	29.573	31.496	46.228	47.427	46.228	47.427
305	25.000	62.000	—	—	1.00	—	—	31.242	35.916	31.242	35.916	53.696	57.427	53.696	57.427
9305	25.000	62.000	—	—	1.00	—	—	31.242	35.916	31.242	35.916	53.696	57.427	53.696	57.427
106	30.000	55.000	—	—	1.00	—	—	34.569	35.839	34.569	35.839	50.013	50.175	50.013	50.175
206	30.000	62.000	—	—	1.00	—	—	35.077	37.592	35.077	37.592	56.388	56.919	56.388	56.919
9206	30.000	62.000	—	—	1.00	—	—	35.077	37.592	35.077	37.592	56.388	56.919	56.388	56.919
306	30.000	72.000	—	—	1.00	—	—	35.077	42.215	35.077	42.215	61.747	66.919	61.747	66.919
9306	30.000	72.000	—	—	1.00	—	—	35.077	42.215	35.077	42.215	61.747	66.919	61.747	66.919
107	35.000	62.000	—	—	1.00	—	—	40.589	40.970	40.589	40.970	56.134	56.665	56.134	56.665
207	35.000	72.000	—	—	1.00	—	—	40.081	45.085	40.081	45.085	64.592	66.919	64.592	66.919
9207	35.000	72.000	—	—	1.00	—	—	40.081	45.085	40.081	45.085	64.592	66.919	64.592	66.919
307	35.000	80.000	—	—	1.50	—	—	41.605	47.313	41.605	47.313	69.596	73.396	69.596	73.396
9307	35.000	80.000	—	—	1.50	—	—	41.605	47.313	41.605	47.313	69.596	73.396	69.596	73.396
108	40.000	68.000	—	—	1.00	—	—	45.669	46.698	45.669	46.698	63.195	62.667	63.195	62.667
208	40.000	80.000	—	—	1.00	—	—	45.080	51.562	45.080	51.562	71.323	74.920	71.323	74.920
9208	40.000	80.000	—	—	1.00	—	—	45.080	51.562	45.080	51.562	71.323	74.920	71.323	74.920
308	40.000	90.000	—	—	1.50	—	—	46.604	55.372	46.604	55.372	78.816	83.396	78.816	83.396
9308	40.000	90.000	—	—	1.50	—	—	46.604	55.372	46.604	55.372	78.816	83.396	78.816	83.396
109	45.000	75.000	—	—	1.00	—	—	47.541	52.677	47.541	52.677	69.342	69.667	69.342	69.667

All dimensions in millimeters.

# ENGINEERING

## Deep Groove Spindle & Turbine (metric) Abutments, *continued*



When planned applications involve bearing removal and remounting, shoulder dimensions should be selected to facilitate dismounting. Minimum shaft shoulders and maximum housing shoulders are preferred, particularly with interference fits.

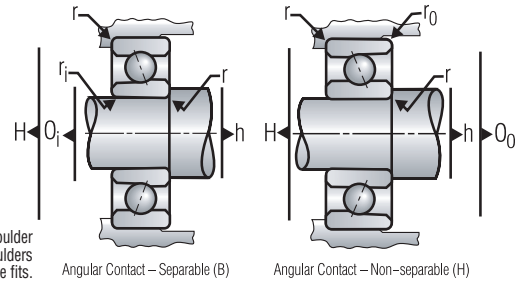
Table 52, *continued*.

Bearing Number	Bearing Dimensions				Maximum Shaft/Housing Fillet Radius Which Bearing Corner Will Clear			Shaft Shoulder Diameters				Housing Shoulder Diameters			
	Bore Dia.	Outside Dia.	Relieved Face Diameter		r	r <sub>i</sub>	r <sub>o</sub>	Open		Shielded or Sealed		Open		Shielded or Sealed	
			O <sub>i</sub>	O <sub>o</sub>				h min.	h max.	h min.	h max.	H min.	H max.	H min.	H max.
209	45.000	85.000	—	—	1.00	—	—	47.541	55.601	47.541	55.601	76.581	79.921	76.581	79.921
9209	45.000	85.000	—	—	1.00	—	—	47.541	55.601	47.541	55.601	76.581	79.921	76.581	79.921
309	45.000	100.000	—	—	2.00	—	—	51.605	61.214	51.605	61.214	86.309	93.396	86.309	93.396
9309	45.000	100.000	—	—	2.00	—	—	51.605	61.214	51.605	61.214	86.309	93.396	86.309	93.396
110	50.000	80.000	—	—	1.00	—	—	55.600	56.845	55.600	56.845	74.371	74.676	74.371	74.676
210	50.000	90.000	—	—	1.00	—	—	55.080	59.436	55.080	59.436	81.940	84.920	81.940	84.920
310	50.000	110.000	—	—	2.00	—	—	58.128	65.913	58.128	65.913	96.063	101.872	96.063	101.872
9310	50.000	110.000	—	—	2.00	—	—	58.128	65.913	58.128	65.913	96.063	101.872	96.063	101.872
111	55.000	90.000	—	—	1.00	—	—	61.097	63.094	61.097	63.094	83.160	83.904	83.160	83.904
211	55.000	100.000	—	—	1.50	—	—	61.605	66.142	61.605	66.142	89.599	93.396	89.599	93.396
311	55.000	120.000	—	—	2.00	—	—	63.129	73.254	63.129	73.254	104.572	111.872	104.572	111.872
312	60.000	130.000	—	—	2.00	—	—	68.128	79.299	68.128	79.299	114.071	121.872	114.071	121.872
9312	60.000	130.000	—	—	2.00	—	—	68.128	79.299	68.128	79.299	114.071	121.872	114.071	121.872
313	65.000	140.000	—	—	2.00	—	—	73.129	86.030	73.129	86.030	122.428	131.872	122.428	131.872
9313	65.000	140.000	—	—	2.00	—	—	73.129	86.030	73.129	86.030	122.428	131.872	122.428	131.872
314	70.000	150.000	—	—	2.00	—	—	78.128	92.735	78.128	92.735	130.810	141.872	130.810	141.872
9314	70.000	150.000	—	—	2.00	—	—	78.128	92.735	78.128	92.735	130.810	141.872	130.810	141.872
315	75.000	160.000	—	—	2.00	—	—	83.129	99.416	83.129	99.416	139.192	151.872	139.192	151.872
316	80.000	170.000	—	—	2.00	—	—	88.128	106.934	88.128	106.934	146.660	161.872	146.660	161.872
317	85.000	180.000	—	—	2.50	—	—	94.653	113.640	94.653	113.640	155.067	170.348	155.067	170.348
318	90.000	190.000	—	—	2.50	—	—	99.652	120.345	99.652	120.345	163.424	180.348	163.424	180.348
320	100.000	215.000	—	—	3.00	—	—	112.192	135.458	112.192	135.458	183.566	202.809	183.566	202.809
222	110.000	200.000	—	—	2.00	—	—	122.000	136.200	122.000	136.200	178.000	187.950	178.000	187.950
322	110.000	240.000	—	—	3.00	—	—	122.192	151.638	122.192	151.638	203.048	227.808	203.048	227.808
232	160.000	290.000	—	—	3.00	—	—	174.000	198.300	174.000	198.300	252.000	276.000	252.000	276.000

All dimensions in millimeters.

# ENGINEERING

## Angular Contact (metric) Abutments



When planned applications involve bearing removal and remounting, shoulder dimensions should be selected to facilitate dismounting. Minimum shaft shoulders and maximum housing shoulders are preferred, particularly with interference fits.

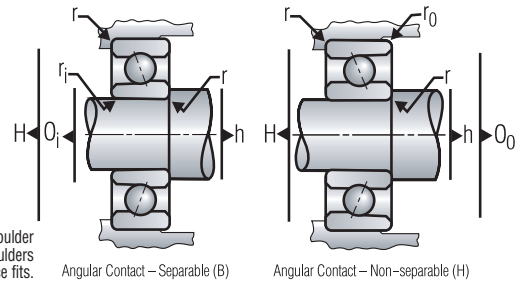
**Table 53. Shaft and housing shoulder diameter abutment dimensions for angular contact (metric) bearings.**

Bearing Number	Bearing Dimensions				Maximum Shaft/Housing Fillet Radius Which Bearing Corner Will Clear			Shaft Shoulder Diameters				Housing Shoulder Diameters			
	Bore Dia.	Outside Dia.	Relieved Face Diameter		r	r <sub>i</sub>	r <sub>o</sub>	Open		Shielded or Sealed		Open		Shielded or Sealed	
			O <sub>i</sub>	O <sub>o</sub>				h min.	h max.	h min.	h max.	H min.	H max.	H min.	H max.
2M3BY3	3.000	10.000	4.303	—	0.15	0.15	—	4.330	5.080	—	—	7.417	8.167	—	—
34H	4.000	16.000	—	13.259	0.30	—	0.25	5.639	7.493	—	—	12.497	14.122	—	—
34BX4	4.000	16.000	5.944	—	0.30	0.13	—	5.639	7.620	—	—	12.497	14.122	—	—
34-5H	5.000	16.000	—	13.259	0.30	—	0.25	5.639	7.493	—	—	12.497	14.122	—	—
19M5BY1	5.000	13.000	7.460	—	0.15	0.15	—	7.632	8.382	—	—	10.668	11.418	—	—
36H	6.000	19.000	—	16.154	0.30	—	0.25	7.620	9.728	—	—	15.138	17.120	—	—
36BX1	6.000	19.000	7.874	—	0.30	0.13	—	7.620	9.728	—	—	15.138	17.120	—	—
37H	7.000	22.000	—	18.771	0.30	—	0.25	8.636	11.760	—	—	17.577	20.117	—	—
38H	8.000	22.000	—	18.771	0.30	—	0.25	9.627	11.760	—	—	17.577	20.117	—	—
38BX2	8.000	22.000	10.490	—	0.30	0.13	—	9.627	11.760	—	—	17.577	20.117	—	—
39H	9.000	26.000	—	22.809	0.30	—	0.25	11.430	14.808	—	—	21.260	23.470	—	—
100H	10.000	26.000	—	22.809	0.30	—	0.25	11.811	14.808	—	—	21.260	24.206	—	—
200H	10.000	30.000	—	26.010	0.64	—	0.38	13.157	16.662	—	—	24.206	26.848	—	—
1901H	12.000	24.000	—	22.098	0.30	—	0.15	14.478	16.002	—	—	20.193	21.590	—	—
101H	12.000	28.000	—	25.019	0.30	—	0.25	13.792	17.018	—	—	23.470	26.187	—	—
101BX48	12.000	28.000	15.215	—	0.30	0.25	—	13.792	17.018	—	—	23.470	26.187	—	—
201H	12.000	32.000	—	28.397	0.38	—	0.38	15.291	18.313	—	—	26.416	28.702	—	—
301H	12.000	37.000	—	31.810	1.00	—	0.50	18.000	19.100	—	—	29.500	30.900	—	—
1902H	15.000	28.000	—	25.959	0.30	—	0.15	17.983	19.939	—	—	24.155	25.552	—	—
102H	15.000	32.000	—	28.245	0.30	—	0.25	16.815	20.269	—	—	26.746	30.201	—	—
102BX48	15.000	32.000	18.415	—	0.30	0.25	—	16.815	20.269	—	—	26.746	30.201	—	—
102BJX6	15.000	32.000	18.415	—	0.30	0.25	—	16.815	20.269	—	—	26.746	30.201	—	—
202H	15.000	35.000	—	31.369	0.64	—	0.38	18.440	20.701	—	—	29.286	31.572	—	—
302H	15.000	42.000	—	37.617	1.00	—	0.50	21.082	24.460	—	—	33.630	35.890	—	—
103H	17.000	35.000	—	30.810	0.30	—	0.25	18.796	21.209	—	—	29.286	33.198	—	—
103BX48	17.000	35.000	19.964	—	0.30	0.25	—	18.796	23.622	—	—	29.286	33.198	—	—
203H	17.000	40.000	—	35.255	0.64	—	0.38	20.574	25.044	—	—	32.182	36.398	—	—
303H	17.000	47.000	—	40.894	1.00	—	0.50	22.860	25.400	—	—	36.830	40.894	—	—
104H	20.000	42.000	—	37.338	0.64	—	0.38	22.809	26.670	—	—	35.306	39.192	—	—
104BX48	20.000	42.000	23.419	—	0.64	0.38	—	22.809	27.762	—	—	35.306	39.192	—	—
204H	20.000	47.000	—	41.783	1.00	—	0.50	24.816	28.702	—	—	38.862	42.189	—	—
304H	20.000	52.000	—	46.660	1.00	—	0.50	25.730	30.886	—	—	42.291	45.212	—	—
1905H	25.000	42.000	—	39.065	0.30	—	0.25	27.737	30.734	—	—	36.551	39.091	—	—
105H	25.000	47.000	—	42.367	0.64	—	0.38	27.813	32.791	—	—	40.310	44.196	—	—
105BX48	25.000	47.000	28.423	—	0.64	0.38	—	27.813	32.791	—	—	39.472	44.196	—	—
205H	25.000	52.000	—	46.609	1.00	—	0.50	29.820	33.528	—	—	43.688	47.193	—	—
305H	25.000	62.000	—	55.677	1.00	—	0.50	31.242	37.490	—	—	49.987	55.372	—	—
106H	30.000	55.000	—	50.089	1.00	—	0.50	33.807	38.379	—	—	47.473	51.181	—	—
106BX48	30.000	55.000	34.722	—	1.00	0.50	—	33.807	38.379	—	—	47.473	51.181	—	—
206H	30.000	62.000	—	56.591	1.00	—	0.50	35.357	41.046	—	—	51.918	56.642	—	—
306H	30.000	72.000	—	64.821	1.00	—	1.00	37.084	44.247	—	—	58.420	64.770	—	—
1907H	35.000	55.000	—	51.841	0.64	—	0.38	39.116	42.037	—	—	48.971	52.070	—	—
107H	35.000	62.000	—	56.515	1.00	—	0.50	39.014	44.526	—	—	52.857	57.988	—	—



# ENGINEERING

## Angular Contact (metric) Abutments, *continued*



When planned applications involve bearing removal and remounting, shoulder dimensions should be selected to facilitate dismounting. Minimum shaft shoulders and maximum housing shoulders are preferred, particularly with interference fits.

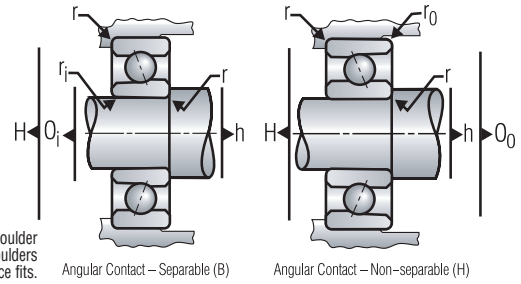
Table 53, *continued*.

Bearing Number	Bearing Dimensions				Maximum Shaft/Housing Fillet Radius Which Bearing Corner Will Clear			Shaft Shoulder Diameters				Housing Shoulder Diameters			
	Bore Dia.	Outside Dia.	Relieved Face Diameter		r	r <sub>i</sub>	r <sub>o</sub>	Open		Shielded or Sealed		Open		Shielded or Sealed	
			O <sub>i</sub>	O <sub>o</sub>				h min.	h max.	h min.	h max.	H min.	H max.	H min.	H max.
107BX48	35.000	62.000	39.167	—	1.00	0.50	—	41.021	43.434	—	—	55.626	57.988	—	—
207H	35.000	72.000	—	65.075	1.00	—	0.50	40.919	47.168	—	—	60.503	66.065	—	—
307H	35.000	80.000	—	72.187	1.50	—	0.76	44.145	50.368	—	—	65.354	71.120	—	—
108H	40.000	68.000	—	62.027	1.00	—	0.50	44.425	49.251	—	—	58.801	63.576	—	—
108BX48	40.000	68.000	44.577	—	1.00	0.50	—	46.609	50.038	—	—	58.369	63.576	—	—
208H	40.000	80.000	—	71.984	1.00	—	0.50	46.203	54.102	—	—	66.548	73.812	—	—
308H	40.000	90.000	—	81.788	1.50	—	0.76	49.149	57.912	—	—	74.600	80.899	—	—
109H	45.000	75.000	—	69.571	1.00	—	0.50	49.403	55.220	—	—	65.253	70.587	—	—
209H	45.000	85.000	—	77.267	1.00	—	0.50	51.206	58.141	—	—	72.390	78.791	—	—
309H	45.000	100.000	—	90.043	1.50	—	0.76	54.102	63.754	—	—	82.093	90.932	—	—
110H	50.000	80.000	—	74.600	1.00	—	0.50	54.407	60.249	—	—	70.307	75.590	—	—
110BX48	50.000	80.000	54.407	—	1.00	0.50	—	55.448	60.249	—	—	70.307	74.600	—	—
210H	50.000	90.000	—	82.880	1.00	—	0.50	56.490	62.484	—	—	77.724	83.515	—	—
310H	50.000	110.000	—	99.111	2.00	—	1.00	65.761	68.580	—	—	88.951	97.815	—	—
211H	55.000	100.000	—	91.745	1.50	—	0.76	63.043	70.206	—	—	85.395	91.948	—	—
212H	60.000	110.000	—	101.041	1.50	—	0.76	68.605	75.565	—	—	94.615	101.422	—	—
312H	60.000	130.000	—	105.664	2.00	—	1.00	68.123	80.569	—	—	111.811	121.869	—	—
113H	65.000	100.000	—	93.675	1.00	—	0.50	69.799	76.276	—	—	89.230	95.199	—	—
113BX48	65.000	100.000	70.079	—	1.00	0.50	—	71.399	76.276	—	—	89.230	93.675	—	—
214H	70.000	125.000	—	115.087	1.50	—	0.76	79.172	88.773	—	—	107.188	115.849	—	—
115H	75.000	115.000	—	107.772	1.00	—	0.50	80.213	88.646	—	—	101.981	109.804	—	—
117H	85.000	130.000	—	121.844	1.00	—	0.50	90.602	100.330	—	—	115.367	124.384	—	—
117BX48	85.000	130.000	92.075	—	1.00	0.50	—	93.167	100.330	—	—	115.367	121.793	—	—
118H	90.000	140.000	—	130.962	1.50	—	0.76	97.028	107.112	—	—	123.800	132.994	—	—
220H	100.000	180.000	—	165.456	2.00	—	1.00	112.954	127.305	—	—	153.975	167.030	—	—

All dimensions in millimeters.

# ENGINEERING

## Angular Contact (inch) Abutments



When planned applications involve bearing removal and remounting, shoulder dimensions should be selected to facilitate dismounting. Minimum shaft shoulders and maximum housing shoulders are preferred, particularly with interference fits.

**Table 54. Shaft and housing shoulder diameter abutment dimensions for angular contact (inch) bearings.**

Bearing Number	Bearing Dimensions				Maximum Shaft/Housing Fillet Radius Which Bearing Corner Will Clear			Shaft Shoulder Diameters				Housing Shoulder Diameters			
	Bore Dia.	Outside Dia.	Relieved Face Diameter		r	r <sub>i</sub>	r <sub>o</sub>	Open		Shielded or Sealed		Open		Shielded or Sealed	
			O <sub>i</sub>	O <sub>o</sub>				h min.	h max.	h min.	h max.	H min.	H max.	H min.	H max.
R1-5B	2.380	7.938	3.531	—	0.15	0.08	—	3.099	3.962	—	—	6.248	7.214	—	—
R1-5H	2.380	7.938	—	6.680	0.15	—	0.08	3.099	4.089	—	—	6.248	7.214	—	—
R144H	3.175	6.350	—	5.715	0.08	—	0.08	3.759	3.962	—	—	5.359	5.740	—	—
R2-5B	3.175	7.938	3.912	—	0.08	0.08	—	3.886	4.470	—	—	6.629	7.214	—	—
R2-5H	3.175	7.938	—	7.214	0.08	—	0.08	3.886	4.740	—	—	6.629	7.214	—	—
R2B	3.175	9.525	4.674	—	0.30	0.15	—	4.547	5.080	—	—	7.417	8.255	—	—
R2H	3.175	9.525	—	7.899	0.30	—	0.15	4.547	5.080	—	—	7.620	8.255	—	—
R2-6H	3.175	9.525	—	8.001	0.15	—	0.08	3.886	5.080	—	—	7.620	8.814	—	—
R3B	4.762	12.700	6.274	—	0.30	0.13	—	6.198	7.010	—	—	10.465	11.328	—	—
R3H	4.762	12.700	—	11.074	0.30	—	0.13	6.198	7.010	—	—	10.465	11.328	—	—
R4B	6.350	15.875	8.459	—	0.30	0.23	—	7.874	9.271	—	—	12.776	14.351	—	—
R4H	6.350	15.875	—	13.462	0.30	—	0.26	7.874	9.271	—	—	12.776	14.351	—	—
R4HX8	6.350	15.875	—	14.681	0.30	—	0.15	7.874	9.271	—	—	13.005	14.351	—	—
R8H	12.700	28.575	—	25.679	0.41	—	0.20	15.875	18.694	—	—	24.689	26.035	—	—

All dimensions in millimeters.

# ENGINEERING

## Random & Selective Fitting and Calibration

### Random and Selective Fitting

Random fitting of precision bearings entails installation of any standard bearing of a given lot on any shaft or in any housing. In order to retain the performance advantages of precision bearings, the shaft and housing should have the same diametric tolerance as the bearing being used. This procedure will result in some extreme fits due to statistical variations of the dimensions involved.

For applications that cannot tolerate extreme fits, it is usually more economical to use selective fitting with calibrated parts rather than reducing the component tolerances.

Selective fitting utilizes a system of sizing bearings, shafts and housings within a diametric tolerance range and selectively assembling those parts, which fall in the same respective area of the range. This practice can have the advantage of reducing the fit range from twice the size tolerance down to 25% of the total tolerance without affecting the average fit.

### Calibration

Bearing calibration can influence the installation and performance characteristics of ball bearings, and should be considered an important selection criteria.

When bearings are calibrated they are sorted into groups whose bores and/or outside diameters fall within a specific increment of the BORE and O.D. tolerance. Knowing the calibration of a bearing and the size of the shaft or housing gives users better control of bearing fits.

Barden bearings are typically sorted in increments of either .00005" (0.00125mm) or .0001" (0.0025mm) or, in the case of metric calibration, 1µm. The number of calibration groups for a given bearing size depends on its diametric tolerance and the size of the calibration increment.

Calibration, if required, must be called for in the last part of the bearing nomenclature using a combination of letters and numbers, as shown in Fig. 23. On calibrated duplex pairs, both bearings in the pair have bore and OD matched within 0.0001" (0.0025mm).

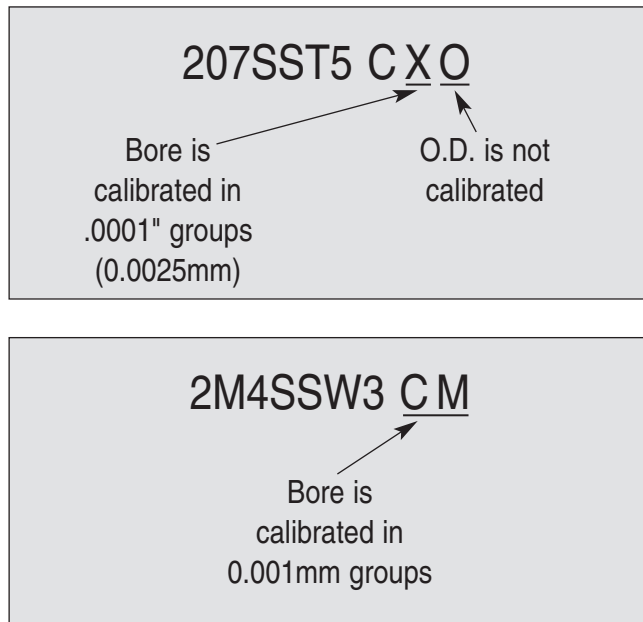
### Random vs. Specific Calibration

Random calibration means the bearing bores and/or O.D.s are measured and the specific increment that the bore or O.D. falls into is marked on the package. With random calibration there is no guarantee of which calibration that will be supplied. Table 55 shows the callouts for various types of random calibration.

**Table 55. Random calibrated bearings are ordered by adding the appropriate code to the bearing number according to this table.**

Code	Type of Random Calibration
C	Bore and O.D. calibrated in groups of .0001" (0.0025mm).
CXO	Bore only calibrated in groups of .0001" (0.0025mm).
COX	O.D. only calibrated in groups of .0001" (0.0025mm).
C44	Bore and O.D. calibrated in groups of .00005" (0.00125mm).
C40	Bore only calibrated in groups of .00005" (0.00125mm).
C04	O.D. only calibrated in groups of .00005" (0.00125mm).
CM	Bore only calibrated in groups of 0.001mm.

**Fig. 23. Example of random calibration nomenclature.**



# ENGINEERING

## Calibration

Specific calibration means the bore and/or O.D.s are manufactured or selected to a specific calibration increment. Barden uses letters (A, B, C, etc) to designate specific .00005" (0.00125mm) groups, and numbers (1, 2, 3, etc.) to designate specific .0001" (0.0025mm) groups. Table 56 shows the letters and numbers, which correspond to the various tolerances increments.

Fig. 25 is exaggerated to help you visualise calibration. The bands around the O.D. and in the bore show bearing tolerances divided into both .00005" (0.00125mm) groups, shown as A, B, C, D and .0001" (0.0025mm) groups, shown as 1, 2, etc.

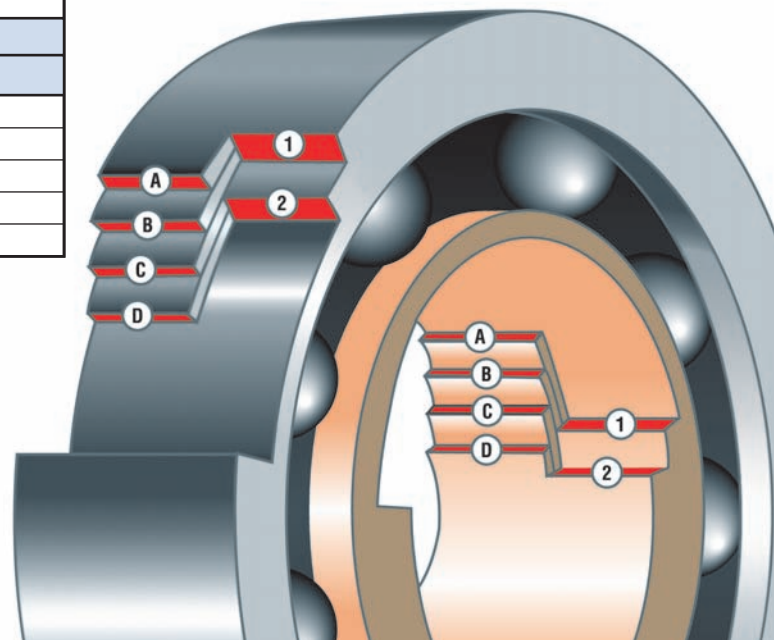
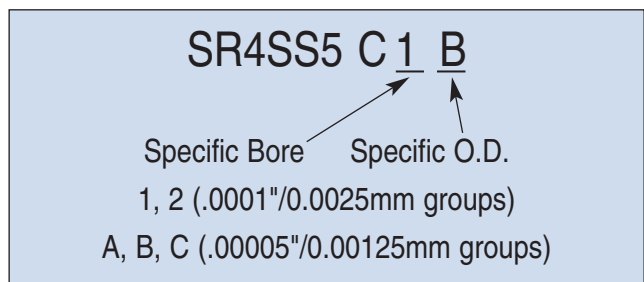
**Table 56. Barden calibration codes for all bearings.**

Bore and O.D. Specific Calibration Codes (inch)		
Size Tolerance (from nominal)	.00005" Calib.	.0001" Calib.
Nominal to $-.00005"$	A	1
$-.00005"$ to $-.0001"$	B	
$-.0001"$ to $-.00015"$	C	2
$-.00015"$ to $-.0002"$	D	
$-.0002"$ to $-.00025"$	E	3
$-.00025"$ to $-.0003"$	F	
$-.0003"$ to $-.00035"$	G	4
$-.00035"$ to $-.0004"$	H	
Specific Calibration Codes, Bore Only (metric)		
Size Tolerance (from nominal)	Code	
Nominal to $-0.001$ mm	CM1	
$-0.001$ to $-0.002$ mm	CM2	
$-0.002$ to $-0.003$ mm	CM3	
$-0.003$ to $-0.004$ mm	CM4	
$-0.004$ to $-0.005$ mm	CM5	

If specific calibrations are requested and cannot be supplied from existing inner or outer ring inventories, new parts would have to be manufactured, usually requiring a minimum quantity. Please check for availability before ordering specific calibrations.

Selective fitting utilising a system of sizing bearings (calibration), shafts and housings and selectively assembling those parts which fall in the same respective are of the range effectively allows users to obtain the desired fit.

**Fig. 24. A typical example of specific calibration.**



**Fig. 25. This drawing, grossly exaggerated for clarity, illustrates specific calibration options (inch) for bore and O.D.**

# ENGINEERING

## Maintaining Bearing Cleanliness

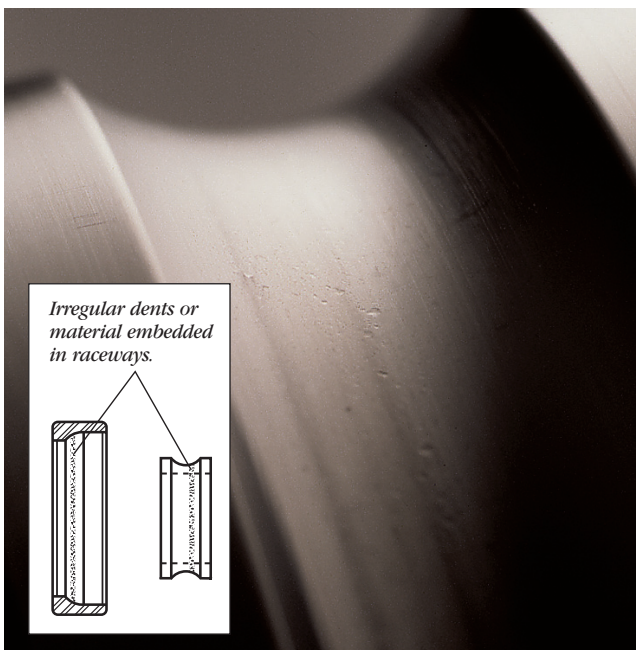
It is vital to maintain a high degree of cleanliness inside precision bearings. Small particles of foreign matter can ruin smooth running qualities and low torque values.

Dirt and contaminants that can impede a bearing's performance are of three varieties:

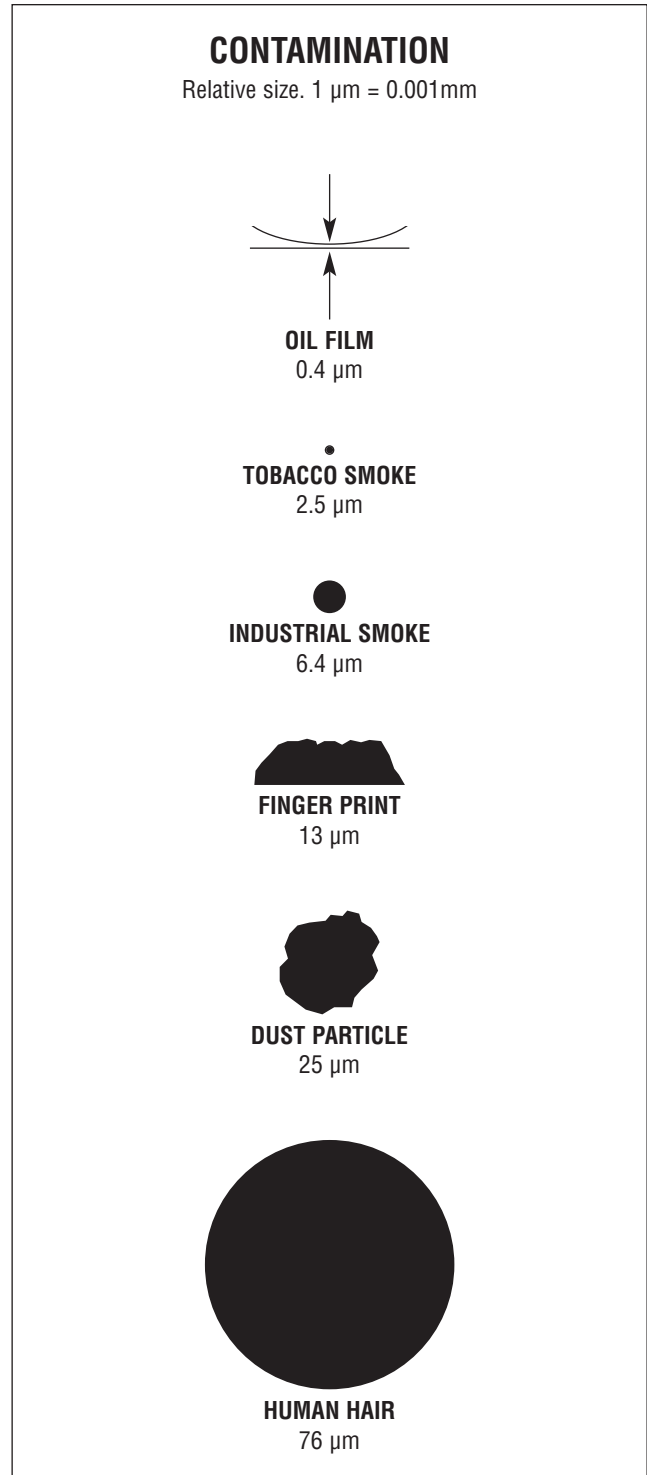
- 1) Airborne contaminants – lint, metal fines, abrasive fines, smoke, dust.
- 2) Transferred contaminants – dirt picked up from one source and passed along to the bearing from hands, work surfaces, packaging, tools and fixtures.
- 3) Introduced dirt – typically from dirty solvents or lubricants.

Contaminants that are often overlooked are humidity and moisture, fingerprints (transferred through handling), dirty greases and oils, and cigarette smoke. All of the above sources should be considered abrasive, corrosive or leading causes of degradation of bearing performance. It should be noted that cleanliness extends not just to the bearings themselves, but to all work and storage areas, benches, transport equipment, tools, fixtures shafts, housings and other bearing components.

When using oil lubricating systems, continuously filter the oil to avoid the introduction of contaminants.



Sometimes, as shown here, the effects of contamination are barely visible.



Comparison of relative sizes of typical contaminants. Oil film under boundary lubrication conditions is only 0.4 micrometers thick, and can be easily penetrated by even a single particle of tobacco smoke.

# ENGINEERING

## Maintaining Bearing Cleanliness

### Use of Shields and Seals

As a rule, it is unwise to mount bearings exposed to the environment. Wherever possible, shielded or sealed bearings should be used, even when enclosed in a protective casing. In situations where inboard sides of bearings are exposed in a closed-in unit, all internal surfaces of parts between the bearings must be kept clean of foreign matter.

If it is impossible to use shielded or sealed bearings or in cases where these are not available (for example, most sizes of angular contact bearings), protective enclosures such as end bells, caps or labyrinth seals may be used to prevent ambient dust from entering the bearings.

### Handling Precision Bearings

All too often bearing problems can be traced back to improper handling. Even microscopic particles of dirt can affect bearing performance.

Precision bearing users should observe proper installation techniques to prevent dirt and contamination.

Foreign particles entering a bearing will do severe damage by causing minute denting of the raceways and balls. The outward signs that contamination may be present include increased vibration, accelerated wear, the inability to hold tolerances and elevated running temperatures. All of these conditions could eventually lead to bearing failure.

Close examination of inner or outer ring races will show irregular dents, scratches or a pock-marked appearance. Balls will be similarly dented, dulled or scratched. The effects of some types of contamination may be hard to see at first because of their microscopic nature.

### Work Area

“Best Practise” bearing installation begins with a clean work area, a good work surface and a comprehensive set of appropriate tooling – all essential elements in order to ensure effective bearing handling and installation.

Good workbench surface materials include wood, rubber, metal and plastic. Generally, painted metal is not desirable as a work surface because it can chip, flake or rust.

Plastic laminates may be acceptable and are easy to keep clean, but are also more fragile than steel or wood and are prone towards the build up of static electricity. Stainless steel, splinter-free hardwoods or dense rubber mats that won’t shred or leave oily residues are the preferred choice.

A clutter-free work area, with good lighting, organised tool storage, handy parts bins and appropriate work fixtures constitutes an ideal working environment.

Under no circumstances should food or drink be consumed on or near work surfaces. Smoking should not be allowed in the room where bearings are being replaced. Bearing installation operations should be located away from other machining operations (grinding, drilling, etc.) to help minimise contamination problems.

Static electricity, as well as operations that may cause steel rings and balls to become magnetised, could result in dust of fine metallic particles being introduced into the bearing. Since all Barden bearings are demagnetised before shipment, if there are any signs that the bearings have become magnetically induced then they should be passed through a suitable demagnetiser while still in their original sealed packaging.

### Proper Tools

Every workbench should have a well-stocked complement of proper tools to facilitate bearing removal and replacement. Suggested tools include wrenches and spanners (unplated and unpainted only), drifts, gauges, gauge-blocks and bearing pullers.

Most spindle bearings are installed with an induction heater (using the principle of thermal expansion) which enlarges the inner ring slightly so that the bearing can be slipped over the shaft. An arbor press can also be used for installing small-bore instrument bearings.

Bearing installers may also require access to a variety of diagnostic tools such as a run-in stand for spindle testing, a bearing balancer and a portable vibration analyser.

# ENGINEERING

## Handling Guidelines

All Barden bearings are manufactured, assembled and packaged in strictly controlled environments. If the full potential of precision bearings is to be realised then the same degree of care and attention must be used in installing them. The first rule for handling bearings is to keep them clean. Consider every kind of foreign material – dust, moisture, fingerprints, solvents, lint, dirty grease – to be abrasive, corrosive or otherwise potentially damaging to the bearing precision. Barden recommends that the following guidelines are used when handling its precision bearings. Particular attention should be made when installing or removing the bearings from shaft or housing assemblies.

1. Keep bearings in their original packaging until ready for use. Nomenclature for each Barden bearing is printed on its box, so there is no need to refer to the bearing itself for identification. Moreover, since the full bearing number appears only on the box, it should be kept with the bearing until installation.
2. Clean and prepare the work area before removing bearings from the packaging.
3. All Barden bearings are demagnetised before shipment. If there is any indication of magnetic induction that would attract metallic contaminants, pass the wrapped bearings through a suitable demagnetiser before unpacking.
4. Once unpacked, the bearings should be handled with clean, dry, talc-free gloves. Note that material incompatibility between the gloves and any cleaning solvents could result in contaminant films being transferred to the bearings during subsequent handling. Clean surgical tweezers should be used to handle instrument bearings.
5. Protect unwrapped bearings by keeping them covered at all times. Use a clean dry cover that will not shed fibrous or particulate contamination into the bearings.
6. Do not wash or treat the bearings. Barden takes great care in cleaning its bearings and properly pre-lubricating them before packaging.
7. Use only bearing-quality lubricants; keep them clean during application and covered between uses. For greased bearings, apply only the proper quantity of grease with a clean applicator. Ensure that all lubricants are within the recommended shelf life before application.
8. For bearing installation and removal only use clean, burr-free tools that are designed for the job. The tools should not be painted or chrome plated as these can provide a source of particulate contamination.
9. Assemble using only clean, burr-free parts. Housing interiors and shaft seats should be thoroughly cleaned before fitting.
10. Make sure bearing rings are started evenly on shafts or in housings, to prevent cocking and distortion.
11. For interference fits, use heat assembly (differential expansion) or an arbor press. Never use a hammer, screwdriver or drift, and never apply sharp blows.
12. Apply force only to the ring being press-fitted. Never strike the outer ring, for example, to force the inner ring onto a shaft. Such practise can easily result in brinelling of the raceway, which leads to high torque or noisy operation.
13. Ensure that all surrounding areas are clean before removing bearings from shaft or housing assemblies. Isolate and identify used bearings upon removal. Inspect the bearings carefully before re-use.
14. Keep records of bearing nomenclature and mounting arrangements for future reference and re-ordering.

### **Barden Warranty**

The Barden Corporation warrants its bearings to be free from defects in workmanship and materials and agrees to furnish a new bearing free of cost or, at its option, to issue a credit for any defective bearing provided such defect shall occur within one year after delivery, the defective bearing returned immediately, charges prepaid, to Barden and upon inspection appears to Barden to have been properly mounted, lubricated and protected and not subjected to abuse. Barden shall not be responsible for any other or contingent charges. This warranty is in lieu of all other warranties, either expressed or implied.

The information contained in this catalogue is intended for use by persons having technical skill, at their own discretion and risk. The data, specifications and characteristics set forth were developed using sound testing and engineering techniques and are believed to be accurate. Every attempt has been made to preclude errors. However, use of this information is the customer's responsibility; The Barden Corporation's sole responsibility or liability is contained in the Warranty statement above.

Due to its continual product improvement programs, The Barden Corporation reserves the right to make changes in products or specifications at any time.

### **Trademark List**

Trademarks of The Barden Corporation include Barden,<sup>™</sup> Barseal,<sup>™</sup> Barshield,<sup>™</sup> Bartemp,<sup>™</sup> Flexeal,<sup>™</sup> Nysorb,<sup>™</sup> SmoothRator<sup>®</sup> and Synchroseal.<sup>™</sup>

- Anderometer – Bendix Corp.
- Arcanol – FAG
- Beacon – Exxon Company
- Exxon – Exxon Company
- ISOFLEX – Kluber Lubrication Corp.
- Mobil – Mobil Oil Corp.
- Rheolube – William F. Nye, Inc.
- Teflon – Du Pont Company
- Viton – Du Pont Company
- Winsor Lube – Anderson Oil & Chemical Co.

### **Conversion Table**

<u>Multiply</u> . . . . .	<u>by</u> . . . . .	<u>To Obtain</u>
Pounds . . . . .	4.4482 . . . . .	Newtons
Newtons . . . . .	.0.2248 . . . . .	Pounds
Pounds . . . . .	.0.4536 . . . . .	Kilograms
Kilograms . . . . .	2.2046 . . . . .	Pounds
Inches . . . . .	25.40 . . . . .	Millimeters
Millimeters . . . . .	.0.03937 . . . . .	Inches
Pounds/Inch <sup>2</sup> . . . . .	6894.76 . . . . .	Pascals
Pascals . . . . .	.0.000145 . . . . .	Pounds/Inch <sup>2</sup>
Inch Pounds . . . . .	.0.1130 . . . . .	Newton Meters
Newton Meters . . . . .	8.8507 . . . . .	Inch Pounds



# BARDEN LITERATURE AND WEB SITES

## The World of Super Precision Bearings

The Barden UK website at [www.bardenbearings.co.uk](http://www.bardenbearings.co.uk) also provides a source of useful information on our super-precision bearing systems.

Dedicated sections present overviews of bearing designs and applications in our major market sectors; together with excerpts from papers presented at the Barden UK Technical Engineering Seminars. Practical advice is also given on the selection, handling and fitting of precision bearings.

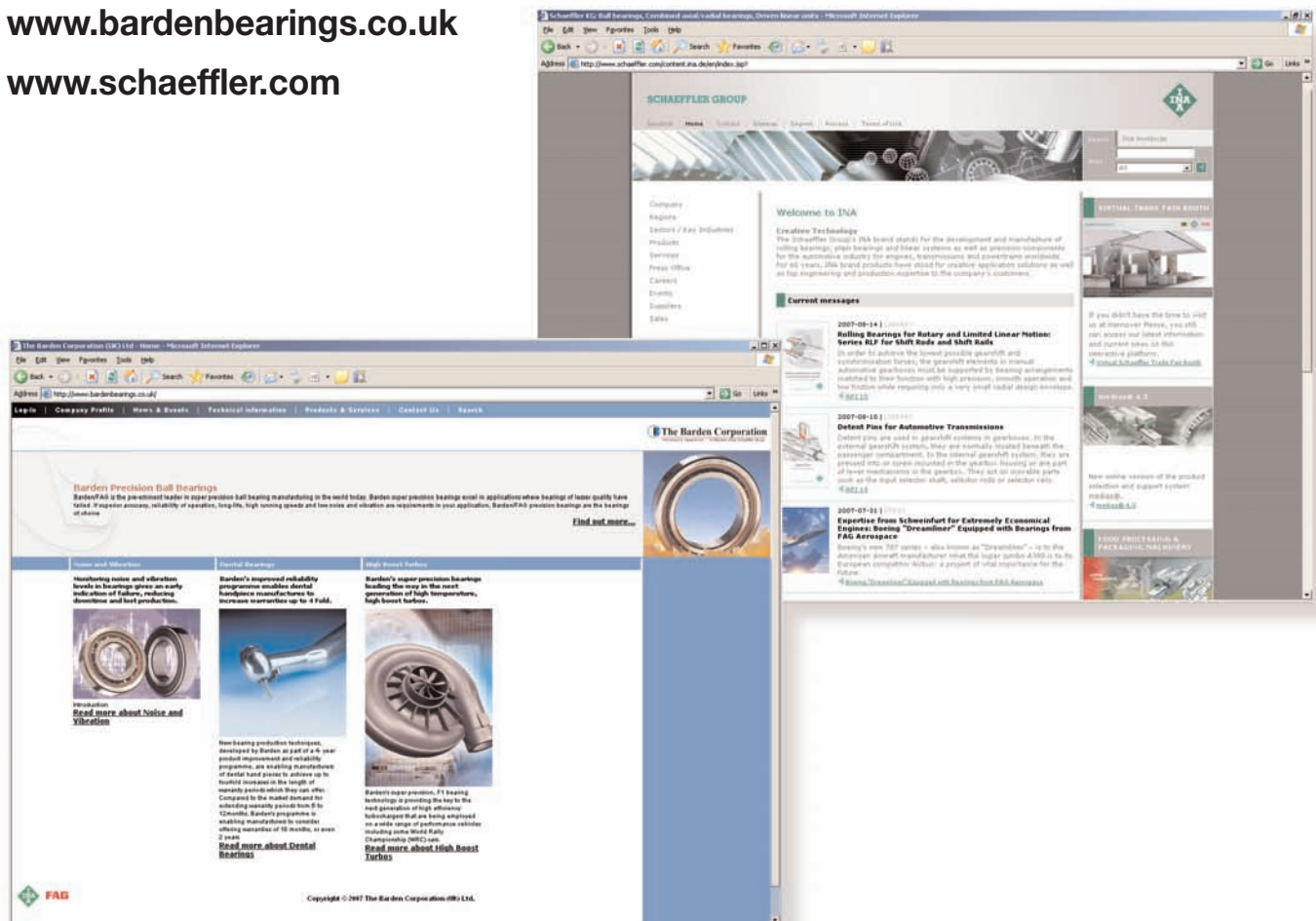
Information about spindle monitoring, bearing calculations, drawings and other precision applications can be found on the Schaeffler website at [www.schaeffler.com](http://www.schaeffler.com)

Examples of other high quality products from the Barden Precision Bearings Group can be found in our specialist Machine Tool catalogue.

Entitled "Super Precision Bearings," the catalogue is published in English, German, Italian and French, and is also available on CD-ROM.

To request a copy of the catalogue, and for further information on other Barden technical engineering publications, please contact your local Barden sales office.

[www.bardenbearings.co.uk](http://www.bardenbearings.co.uk)  
[www.schaeffler.com](http://www.schaeffler.com)



# ENGINEERING

## Index

- ABEC standards, exclusions from .....109  
ABEC standards ..... 5, 108-113  
Abutment tables .....130-138  
Aerospace bearings.....60-61  
Angular contact bearings.....35-47  
    Angular contact inch tables.....40-41  
    Angular contact metric tables .....42-47  
Anti-corrosion .....75  
Applications .....7, 49-65, 71  
    Aerospace.....60-61  
    Auto sport .....56-57  
    Canning .....64-65  
    Dental handpiece bearings .....52-53  
    Formula 1 racing .....56-57  
    Gyro .....58-59  
    Magnetic spindle touchdown bearings .....54-55  
    Touchdown bearings .....54-55  
    Vacuum pumps .....54-55  
    X-ray .....62-63  
Attainable speeds .....84 (also see *Product Tables*)  
Auto sport bearings .....56-57  
Axial adjustment .....96  
Axial play (end play).....90-91  
Axial yield .....90, 95  
Ball and ring materials .....71-74  
Ball complement .....92-94  
Barseal .....82-83  
Barshield .....82-83  
Bearing  
    Applications .....7, 49-65  
    Closures (seals/shields) .....82-83  
    Configurations .....6  
    Diameters .....71 (also see *Product Tables*)  
    Handling .....142-143  
    Installation .....142-143  
    Life .....114-120  
    Nomenclature, angular contact .....37  
    Nomenclature, deep groove .....13  
    Performance .....114-119  
    Precision classes .....5  
    Selection .....69-70  
    Sizes .....6, 71 (also see *Product Tables*)  
    Types .....69-74 (also see *Configurations*)  
    Yield .....95  
Boundary lubrication .....100  
Cages .....77-81  
    Angular contact .....77, 80-81  
    Characteristics .....77-81  
    Deep groove .....77-79  
    dN (values).....78, 80  
Calibration (classification) .....139-140  
Canning bearings .....64-65  
Capacity, dynamic, static .....114-115 (also see *Product Tables*)  
Cartridge width bearings .....6 (also see *Product Tables*)  
Ceramics (hybrid bearings) .....72-74  
Cleanliness of bearings .....141-143  
Closures .....82-83  
    Barseal .....82-83  
    Barshield .....82-83  
    Flexeal .....82-83  
    Synchro seal .....82-83  
    Viton Barseal .....82-83  
Configurations .....6  
Contact angle .....88-89 (also see *Product Tables*)  
Contamination .....141-143  
Conversion table .....144  
Corner radii .....128, 130-138 (also see *Product Tables*)  
Cronidur 30 .....71, 74, 117  
DB, DF and DT mounting .....96-98  
Deep groove bearings .....11-33  
Deep groove bearing product tables .....16-33  
    Flanged, inch instrument .....22-23  
    Inch instrument .....16-19  
    Inch instrument, flanged .....22-23  
    Inch, thin section .....24-27  
    Metric instrument .....20-21  
    Metric, spindle & turbine .....28-33  
    Thin section, inch .....24-27  
    Spindle & turbine, metric .....28-33  
Dental handpiece bearings .....52-53  
Diameter series .....71  
Direct lubrication .....106  
dN (definition).....84  
Dry film lubricants .....76  
Duplex bearings .....96-98  
Dynamic load ratings .....114, 115 (also see *Product Tables*)  
Elastohydrodynamic lubrication films .....100  
End play (axial play) .....90-91  
Engineering .....67-143  
Equipment life .....see *Life Calculation*  
Fatigue life .....116-119  
Fillet radii .....128, 130-138 (also see *Product Tables*)  
Finish, bearing seats .....124  
Fitting practice .....124-140  
Fitting (random) .....139  
Fitting (selective) .....139  
Flanged bearings .....12, 22-23  
Flexeal .....82-83  
Formula 1 racing bearings .....56-57  
Frequency analysis .....see *Vibration*  
Full ball complement, bearings with .....60  
Functional testing .....122, 123  
Geometric accuracy .....108-113  
Grease life .....120  
Greases .....100-104, 120  
Gyro bearings .....58-59  
Handling bearings .....142-143  
Housing shoulder diameters .....129-138  
Housing size determination .....124-126  
Hybrid bearings .....72-74  
Inch bearings .....14-19, 22-27, 40-41  
    Angular contact .....40-41  
    Deep groove .....14-19, 22-27  
Installation of bearings .....142-143 (also see *Fitting Practice*)  
Internal clearance .....85-87 (also see *Radial Play*)  
Internal design parameters .....85-94, 109  
Life calculation .....114-120  
Limiting speeds .....84 (also see *Product Tables*)  
Load ratings,  
    dynamic, static .....114-115 (also see *Product Tables*)  
Lubricant selection .....100-105  
Lubricant viscosity .....100-102  
Lubrication .....76, 100-107  
Lubrication, direct .....106  
Lubrication grease life .....120  
Lubrication systems .....106  
Lubrication windows .....106-107  
Magnetic spindle touchdown bearings .....54-55  
Matched pairs .....96-98  
Materials (rings, balls) .....71-74  
Metric bearings .....14-15, 20-21, 28-33, 42-47  
    Angular contact .....42-47  
    Deep groove .....14-15, 20-21, 28-33  
Mounting and fitting .....124-143  
Mounting surfaces .....124 (also see *Mounting & Fitting*)  
Mounting bearing sets (DB, DF, DT, etc.) .....96-98  
Nomenclature .....13, 37  
    Angular contact .....37  
    Deep groove .....13  
Nonferrous bearing housings .....127  
Non-destructive testing .....122  
Nonseparable bearings .....6, 36, 70 (also see *Product Tables*)  
Numbering system .....see *Nomenclature*  
Oil lubrication systems .....106  
Oils .....100-106  
Open bearing design .....70-71  
Operating conditions .....69  
Precision classes .....5, 108-113 (also see *ABEC*)  
Performance and life .....114-123  
Petroleum oils .....103, 105  
Preloading .....95-99  
Prelubrication of bearings .....101  
Product engineering services .....9  
Product tables .....16-33, 40-47  
    Angular contact .....40-47  
    Deep groove .....16-33  
Quality control .....8  
Raceway curvature .....85  
Radial capacity, static .....see *Product Tables*  
Radial internal clearance .....85-87  
Radial play .....85  
Radial play codes .....86-87  
Radial runout .....108-113  
Radial yield .....95, 122  
Random and selective fitting .....139-140  
Retainers .....see *Cages*  
Seals .....82-83  
    Barseal .....82-83  
    Barshield .....82-83  
    Flexeal .....82-83  
    Synchro seal .....82-83  
    Viton Barseal .....82-83  
Separable bearings .....6, 36, 70 (also see *Product Tables*)  
Separators .....see *Cages*  
Series descriptions .....14-15, 39  
    Angular contact .....39  
    Deep groove .....14-15  
Service life .....114-120  
Shaft and housing fits .....124-140  
Shaft shoulder diameters .....130-138  
Shaft size determination .....124-140  
Shields .....82-83  
Shoulder diameters .....130-138  
Silicon nitride .....72-74  
Sizes .....4, 6 (also see *Product Tables*)  
Solid lubrication .....76, 100  
Spacers .....98  
Special applications .....49-65  
    Aerospace .....60-61  
    Auto sport .....56-57  
    Canning .....64-65  
    Dental handpiece bearings .....52-53  
    Formula 1 racing .....56-57  
    Gyro .....58-59  
    Magnetic spindle touchdown .....54-55  
    Touchdown bearings .....54-55  
    Vacuum pumps .....54-55  
    X-ray .....62-63  
Specialised preloads .....see *Preloading*  
Speedability factor dN .....84  
Speedability, in lubrication .....105  
Speed, attainable .....see *Product Tables*  
Spring preloading .....95-96  
Stainless steel (AISI 440C) .....71  
Standards (ABEC, ANSI, ISO) .....5, 108-109  
Static capacity, radial, thrust .....see *Product Tables*  
Stiffness .....see *Duplex, Preloading, Yield*  
Surface engineering .....75-76  
Synchro seal .....82-83  
Synthetic oils .....103-105  
Temperature limits  
    Ball and ring materials .....71-72  
    Cage materials .....78, 80  
    Lubricants .....100-105  
    Seals and shields .....83  
Testing (functional, nondestructive) .....122-123  
Thrust capacity, static .....see *Product Tables*  
Tolerances .....108-113  
Tool steels (M50) .....71  
Torque .....122  
Touchdown bearings .....54-55  
Vacuum pump bearings .....54-55  
Vibration .....121  
Viscosity, lubricants .....100-101  
Viton Barseal .....82-83  
Warranty .....144  
Wear resistance .....75-76  
X-life ultra bearings .....74  
X-ray tube bearings .....62-63  
Yield, axial, radial .....95, 122



**The Barden Corporation (UK) Ltd**

Plymbridge Road, Estover,  
Plymouth PL6 7LH, England  
Phone: +44 (0)1752 735 555 Fax: +44 (0)1752 733 481  
E-mail: bardenbearings@schaeffler.com www.bardenbearings.co.uk

**The Barden Corporation**

PO Box 2449, 200 Park Avenue, Danbury,  
Connecticut 06813-2449, USA  
Phone: +1 2037 442 211 Fax: +1 2037 443 756  
E-mail: sales@bardenbearings.com www.bardenbearings.com

**Schaeffler KG**

Georg-Schäfer Straße 30,  
97421 Schweinfurt, Germany  
Phone: +49 (0)9721 914 457 Fax: +49 (0)9721 913 435  
E-mail: faginfo@schaeffler.com www.schaeffler.com

